

**SEARS**

**OWNER'S  
MANUAL**

**MODEL NO.  
944.528411**

**Caution:**  
Read and follow  
all Safety Rules  
and Instructions  
Before Operating  
This Equipment

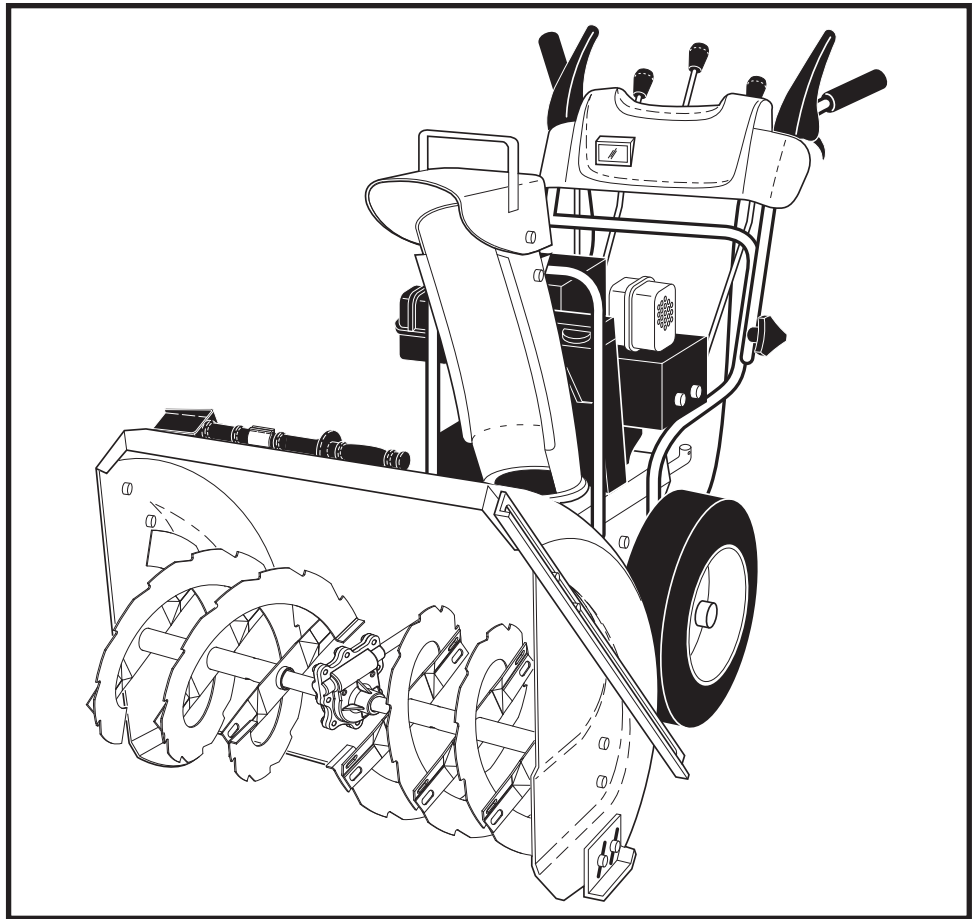

**CRAFTSMAN®**

**1350 SERIES B&S ENGINE  
27" TWO-STAGE  
POWER-PROPELLED  
SNOW THROWER**

- **Assembly**
- **Operation**
- **Maintenance**
- **Service and Adjustments**
- **Repair Parts**

# IMPORTANT

## Safe Operation Practices for Walk-Behind Snow Throwers

This snow thrower is capable of amputating hands and feet and throwing objects. Failure to observe the following safety instructions could result in serious injury.



Look for this symbol to point out important safety precautions. It means **CAUTION!!! BECOME ALERT!!! YOUR SAFETY IS INVOLVED.**



**WARNING:** Always disconnect spark plug wire and place it where it cannot contact plug in order to prevent accidental starting when setting up, transporting, adjusting or making repairs.



**WARNING:** This snow thrower is for use on sidewalks, driveways and other ground level surfaces. Caution should be exercised while using on sloping surfaces. Do not use snow thrower on surfaces above ground level such as roofs of residences, garages, porches or other such structures or buildings.



**WARNING:** Snow throwers have exposed rotating parts, which can cause severe injury from contact, or from material thrown from the discharge chute. Keep the area of operation clear of all persons, small children and pets at all times including startup.



**CAUTION:** Muffler and other engine parts become extremely hot during operation and remain hot after engine has stopped. To avoid severe burns on contact, stay away from these areas.



**WARNING:** Engine exhaust, some of its constituents, and certain vehicle components contain or emit chemicals known to the State of California to cause cancer and birth defects or other reproductive harm.

### Training

1. Read, understand and follow all instructions on the machine and in the manual(s) before operating this unit. Be thoroughly familiar with the controls and the proper use of the equipment. Know how to stop the unit and disengage the controls quickly.
2. Never allow children to operate the equipment. Never allow adults to operate the equipment without proper instruction.
3. Keep the area of operation clear of all persons, particularly small children.
4. Exercise caution to avoid slipping or falling, especially when operating the snow thrower in reverse.

### Preparation

1. Thoroughly inspect the area where the equipment is to be used and remove all doormats, sleds, boards, wires, and other foreign objects.
2. Disengage all clutches and shift into neutral before starting the engine (motor).
3. Do not operate the equipment without wearing adequate winter garments. Avoid loose fitting clothing that can get caught in moving parts. Wear footwear that will improve footing on slippery surfaces.
4. Handle fuel with care; it is highly flammable
  - (a) Use an approved fuel container.
  - (b) Never add fuel to a running engine or hot engine.
  - (c) Fill fuel tank outdoors with extreme care. Never fill fuel tank indoors.
  - (d) Never fill containers inside a vehicle or on a truck or trailer bed with a plastic liner. Always place containers on the ground, away from your vehicle, before filling.
  - (e) When practical, remove gas-powered equipment from the truck or trailer and refuel it on the ground. If this is not possible, then refuel such equipment on a trailer with a portable container, rather than from a gasoline dispenser nozzle.

- (f) Keep the nozzle in contact with the rim of the fuel tank or container opening at all times, until refueling is complete. Do not use a nozzle lock-open device.
  - (g) Replace gasoline cap securely and wipe up spilled fuel.
  - (h) If fuel is spilled on clothing, change clothing immediately.
5. Use extension cords and receptacles as specified by the manufacturer for all units with electric drive motors or electric starting motors.
  6. Adjust the collector housing height to clear gravel or crushed rock surface.
  7. Never attempt to make any adjustments while the engine (motor) is running (except when specifically recommended by manufacturer).
  8. Always wear safety glasses or eye shields during operation or while performing an adjustment or repair to protect eyes from foreign objects that may be thrown from the machine.

### Operation

1. Do not put hands or feet near or under rotating parts. Keep clear of the discharge opening at all times.
2. Exercise extreme caution when operating on or crossing gravel drives, walks, or roads. Stay alert for hidden hazards or traffic.
3. After striking a foreign object, stop the engine (motor), remove the wire from the spark plug, disconnect the cord on electric motors, thoroughly inspect the snow thrower for any damage, and repair the damage before restarting and operating the snow thrower.
4. If the unit should start to vibrate abnormally, stop the engine (motor) and check immediately for the cause. Vibration is generally a warning of trouble.
5. Stop the engine (motor) whenever you leave the operating position, before unclogging the collector/impeller housing or discharge chute, and when making any repairs, adjustments or inspections.

6. When cleaning, repairing or inspecting the snow thrower, stop the engine and make certain the collector/impeller and all moving parts have stopped. Disconnect the spark plug wire and keep the wire away from the plug to prevent someone from accidentally starting the engine.
7. Do not run the engine indoors, except when starting the engine and for transporting the snow thrower in or out of the building. Open the outside doors; exhaust fumes are dangerous.
8. Exercise extreme caution when operating on slopes.
9. Never operate the snow thrower without proper guards, and other safety protective devices in place and working.
10. Never direct the discharge toward people or areas where property damage can occur. Keep children and others away.
11. Do not overload the machine capacity by attempting to clear snow at too fast a rate.
12. Never operate the machine at high transport speeds on slippery surfaces. Look behind and use care when operating in reverse.
13. Disengage power to the collector/impeller when snow thrower is transported or not in use.
14. Use only attachments and accessories approved by the manufacturer of the snow thrower (such as wheel weights, counterweights, or cabs).
15. Never operate the snow thrower without good visibility or light. Always be sure of your footing, and keep a firm hold on the handles. Walk; never run.
16. Never touch a hot engine or muffler.

## Clearing a Clogged Discharge Chute

Hand contact with the rotating impeller inside the discharge chute is the most common cause of injury associated with snow throwers. Never use your hand to clean out the discharge chute. To clear the chute:

1. SHUT THE ENGINE OFF!
2. Wait 10 seconds to be sure the impeller blades have stopped rotating.
3. Always use a clean-out tool, not your hands.

## Maintenance and Storage

1. Check shear bolts and other bolts at frequent intervals for proper tightness to be sure the equipment is in safe working condition.
2. Never store the machine with fuel in the fuel tank inside a building where ignition sources are present such as hot water heaters, space heaters, or clothes dryers. Allow the engine to cool before storing in any enclosure.
3. Always refer to operator's manual for important details if the snow thrower is to be stored for an extended period.
4. Maintain or replace safety and instruction labels, as necessary.
5. Run the machine a few minutes after throwing snow to prevent freeze-up of the collector/impeller.

---

# TABLE OF CONTENTS

---

<b>SAFETY RULES</b> .....	<b>2-3</b>
<b>PRODUCT SPECIFICATIONS</b> .....	<b>4</b>
<b>CUSTOMER RESPONSIBILITIES</b> .....	<b>4</b>
<b>WARRANTY</b> .....	<b>4</b>
<b>ASSEMBLY / PRE-OPERATION</b> .....	<b>6-8</b>
<b>OPERATION</b> .....	<b>9-14</b>

<b>MAINTENANCE</b> .....	<b>15-16</b>
<b>MAINTENANCE SCHEDULE</b> .....	<b>15</b>
<b>SERVICE AND ADJUSTMENTS</b> .....	<b>17-19</b>
<b>STORAGE</b> .....	<b>19</b>
<b>TROUBLESHOOTING</b> .....	<b>20</b>
<b>REPAIR PARTS</b> .....	<b>22-46</b>
<b>SEARS SERVICE</b> .....	<b>BACK COVER</b>

## LIMITED TWO (2) YEAR WARRANTY ON CRAFTSMAN SNOW THROWER

For two (2) years from date of purchase Sears Canada, Inc. will repair or replace, at Sears option, free of charge parts which are defective as a result of material or workmanship.

### COMMERCIAL OR RENTAL USE:

Warranty on Snow Thrower will be 90 days from date of purchase if used for commercial or rental purposes.

### This Warranty does **NOT** cover:

1. **Pre-delivery set-up.**
2. **Expendable items which become worn during normal use, such as belts, spark plugs, air cleaners, and shear pins, as well damage to the engine resulting from operating snow thrower with insufficient oil.**
3. **Repairs necessary because of operator abuse or negligence, including the failure to operate and maintain the equipment according to the instructions contained in the Owner's Manual.**
4. **Tire replacement or repair caused by punctures from outside objects, such as nails, thorns, stumps or glass.**

Warranty service is available by returning the Craftsman Snow Thrower to the nearest Sears Service Centre/Department in Canada. This warranty applies only while this product is in use in Canada.

This warranty is in addition to any statutory warranty and does NOT exclude or limit legal rights you may have but shall run concurrently with applicable provincial legislation. Furthermore, some provinces do not allow limitations on how long an implied warranty will last, so the above limitations may not apply to you.

**Sears Canada, Inc., Toronto, Ontario M5B 2B8**

**CONGRATULATIONS** on your purchase of a new snow thrower. It has been designed, engineered and manufactured to give best possible dependability and performance.

Should you experience any problem you cannot easily remedy, please contact your nearest Sears service centre/department. We have competent, well-trained technicians and the proper tools to service or repair this unit.

Please read and retain this manual. The instructions will enable you to assemble and maintain your snow thrower properly. Always observe the "SAFETY RULES".

SERIAL NUMBER: \_\_\_\_\_

DATE OF PURCHASE: \_\_\_\_\_

THE MODEL AND SERIAL NUMBERS WILL BE FOUND ON A DECAL ATTACHED TO THE REAR OF THE SNOW THROWER HOUSING.

YOU SHOULD RECORD BOTH SERIAL NUMBER AND DATE OF PURCHASE AND KEEP IN A SAFE PLACE FOR FUTURE REFERENCE.

## PRODUCT SPECIFICATIONS

Gasoline Capacity and Type:	4,54 Liters Unleaded Regular only
Oil Type (API SG-SL):	SAE 5W-30 or 10W-30 (0°F to +40°F / -18°C to +5°C) Synthetic SAE 5W-30 or 10W-30 (below 0°F / -18°C)
Oil Capacity:	0,8 Liters
Spark Plug: Gap:	Champion RC12YC 0,072 mm

## CUSTOMER RESPONSIBILITIES

- Read and observe the safety rules.
- Follow a regular schedule in maintaining, caring for and using your snow thrower.
- Follow the instructions under "Maintenance" and "Storage" sections of this owner's manual.

# PARTS PACKED SEPARATELY IN CARTON

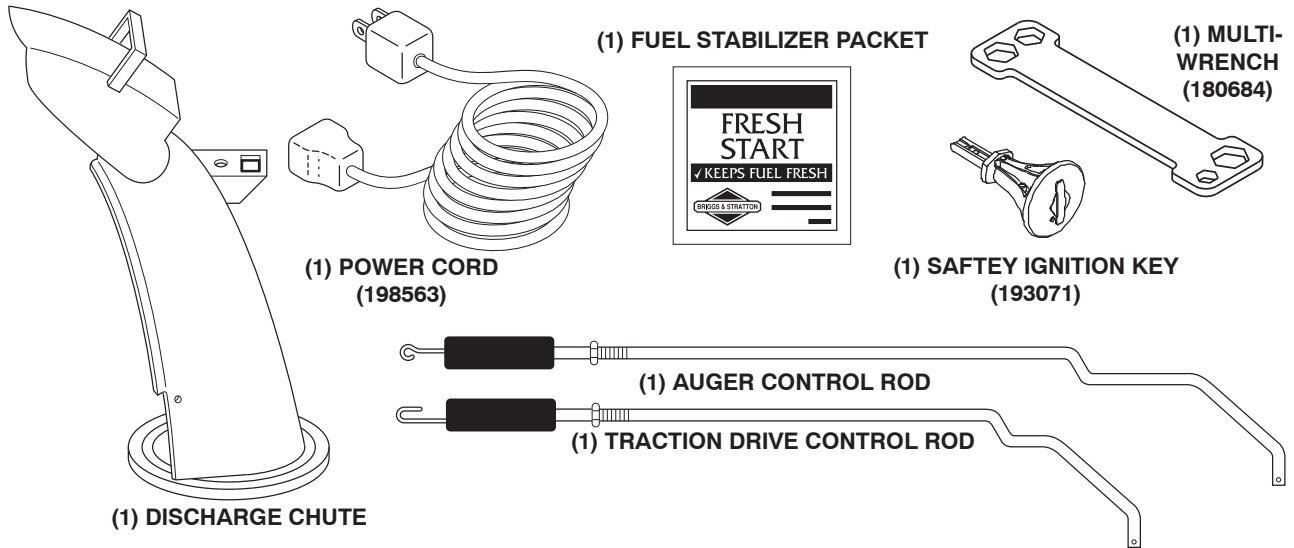

## EXTRA SHEAR BOLTS AND NUTS

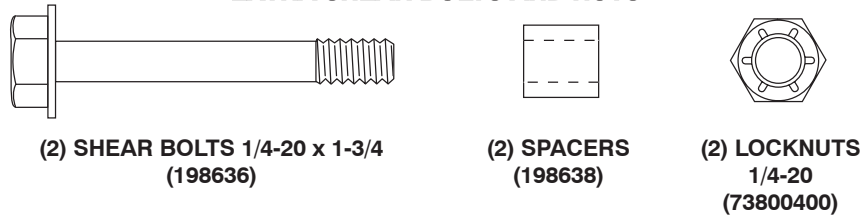

## ROTATOR HEAD MOUNTING

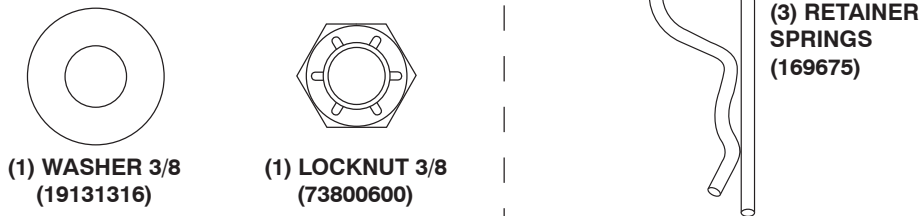

## CHUTE DEFLECTOR REMOTE CONTROL

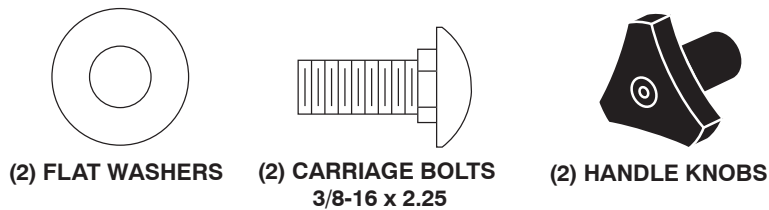
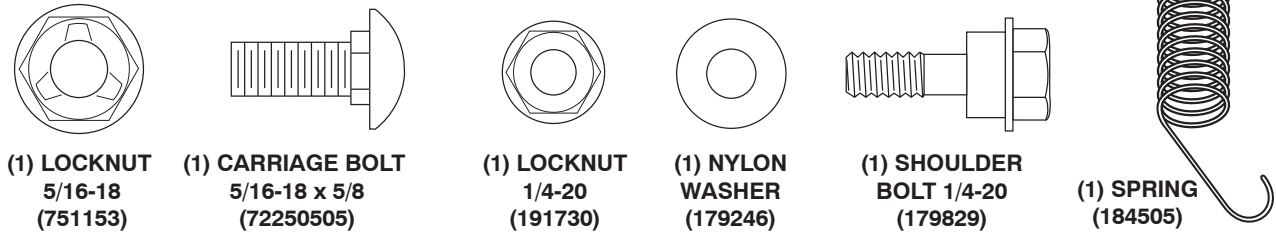

# ASSEMBLY / PRE-OPERATION

Read these instructions and this manual in its entirety before you attempt to assemble or operate your new snow thrower. Reading the entire manual will familiarize you with the unit, which will assist you in assembly, operation and maintenance of the product.

Your new snow thrower has been assembled at the factory with the exception of those parts left unassembled for shipping purposes. All parts such as nuts, washers, bolts, etc., necessary to complete the assembly have been placed in the parts bag. To ensure safe and proper operation of your snow thrower, all parts and hardware you assemble must be tightened securely. Use the correct tools as necessary to ensure proper tightness.

## REMOVE SNOW THROWER FROM CARTON

1. Remove all accessible loose parts and parts boxes from carton.
2. Cut down all four corners of carton and lay panels flat.
3. Remove the two (2) screws securing the auger housing to the pallet.
4. Remove all packing materials except plastic tie holding speed control rod to lower handle.
5. Remove the two (2) plastic ties securing the upper handle to the pallet.
6. Remove snow thrower from carton and check carton thoroughly for additional loose parts.

## HOW TO SET UP YOUR SNOW THROWER

### TOOL BOX (See Fig. 10)

A toolbox is provided on your snow thrower. The toolbox is located on top of the belt cover. Store the extra shear bolts, nuts and multi-wrench provided in parts bag in the toolbox.

**NOTE:** The multi-wrench may be used for assembly of the chute rotator head to snow thrower and making adjustments to the skid plates.

### UNFOLD UPPER HANDLE

1. Raise upper handle to the operating position and tighten handle knobs securely. Additional carriage bolts, washers and handle knobs are in bag of parts. Use to secure upper handle to lower handle. Install in lower holes in handles.

## INSTALL SPEED CONTROL ROD (See Figs. 1 and 2)

1. Remove plastic tie securing rod to lower handle.
2. Insert rod into speed control bracket and secure with retainer spring.

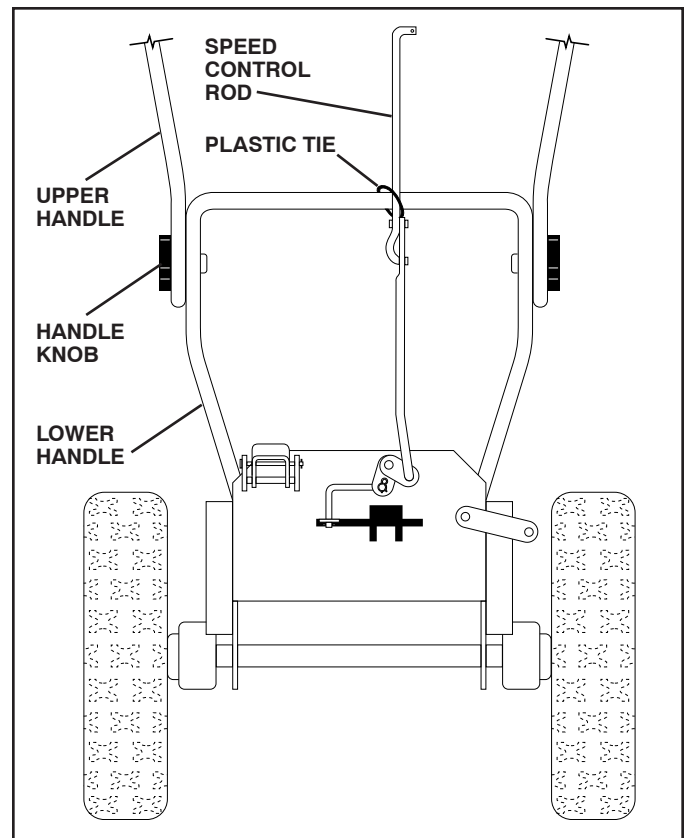

FIG. 1

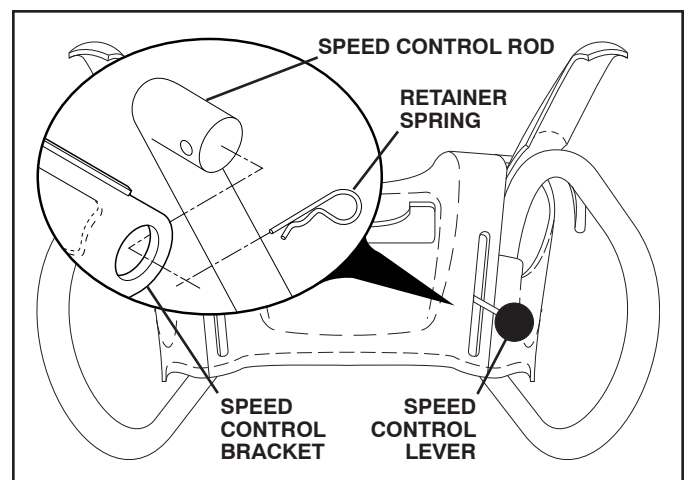

FIG. 2

# ASSEMBLY / PRE-OPERATION

## INSTALL TRACTION DRIVE CONTROL ROD (See Figs. 3 and 4)

The traction drive control rod has the long loop on the end of the spring as shown.

1. Slide rubber sleeve up rod and hook end of spring into pivot bracket with loop opening down as shown.
2. With top end of rod positioned under left side of control panel, push rod down and insert top end of rod into hole in drive control bracket. Secure with retainer spring.

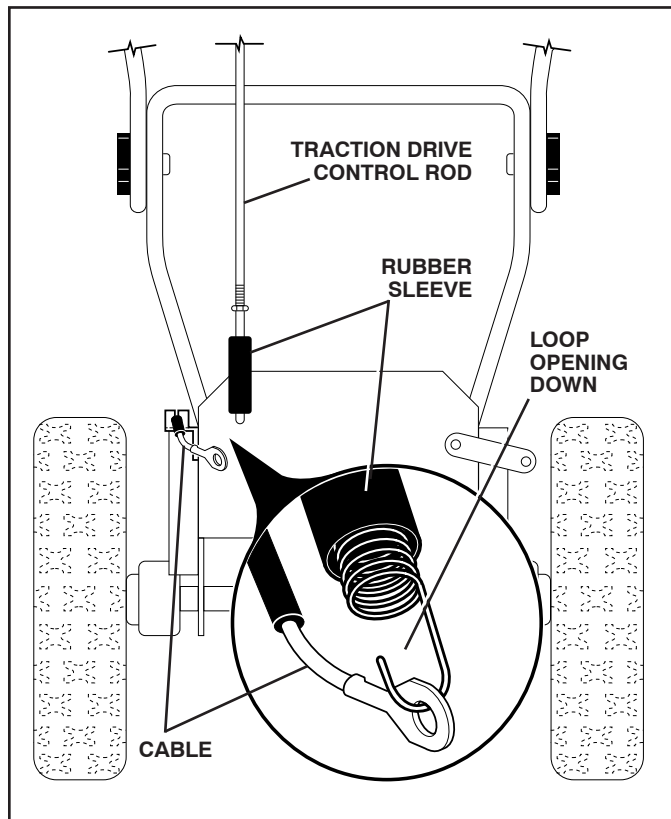

FIG. 3

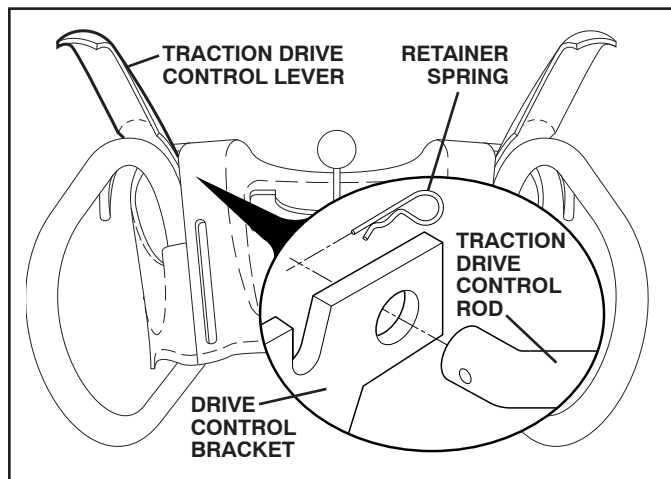

FIG. 4

## INSTALL AUGER CONTROL ROD (See Figs. 5 and 6)

The auger control rod has the short loop on the end of the spring as shown.

1. Slide rubber sleeve up rod and hook end of spring into control arm with loop opening up as shown.
2. With top end of rod positioned under right side of control panel, push down on rod and insert end of rod into hole in auger control bracket. Secure with retainer spring.

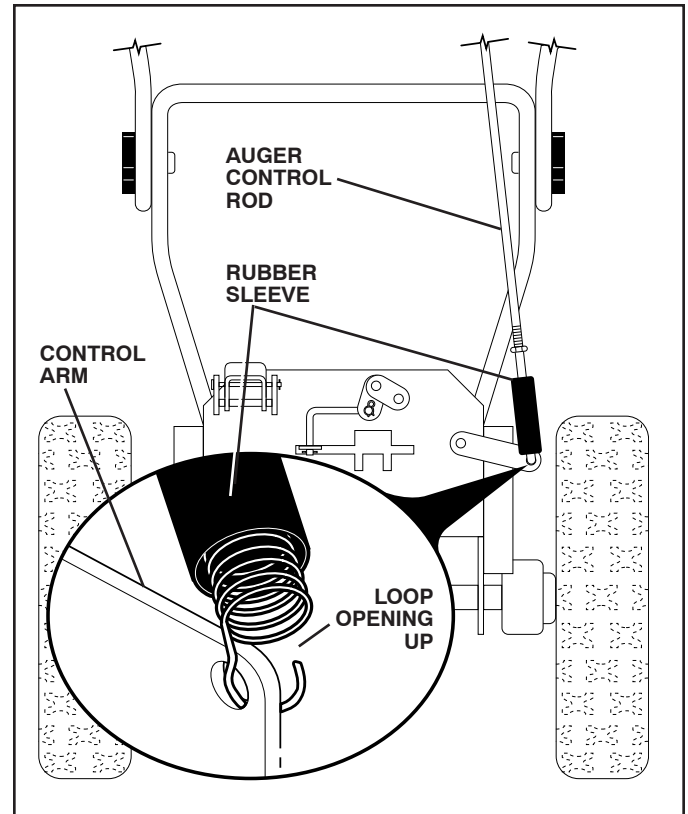

FIG. 5

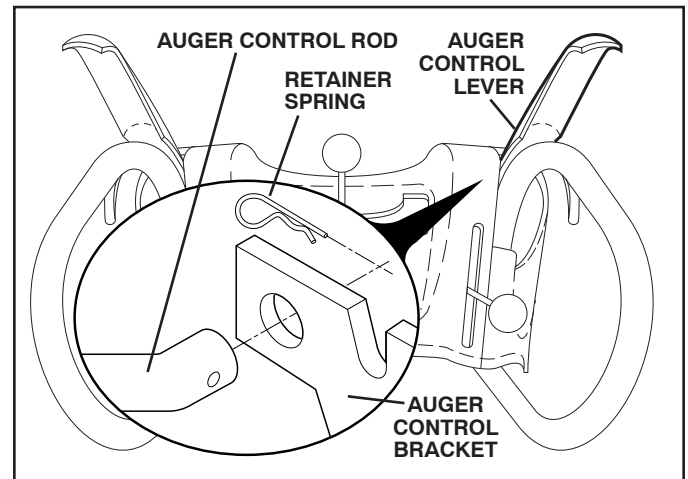

FIG. 6

# ASSEMBLY / PRE-OPERATION

## INSTALL DISCHARGE CHUTE / CHUTE ROTATOR HEAD (See Fig. 7)

**NOTE:** The multi-wrench provided in your parts bag may be used to install the chute rotator head.

1. Place discharge chute assembly on top of chute base with discharge opening toward front of snow thrower.
2. Position chute rotator head over chute bracket. If necessary, rotate chute assembly to align square and pin on underside of chute rotator head with holes in chute bracket.
3. With chute rotator head and chute bracket aligned, position chute rotator head on pin and threaded stud of mounting bracket.
4. Install 3/8 washer and locknut on threaded stud and tighten securely.

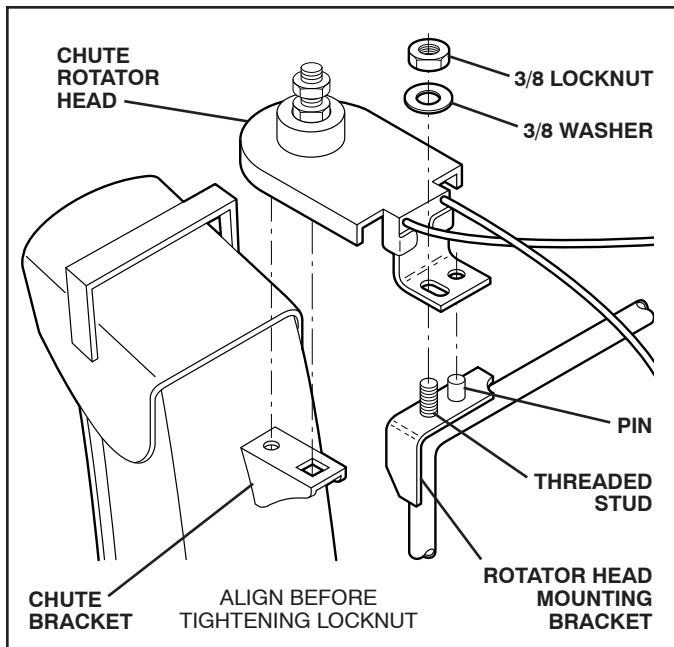

FIG. 7

## INSTALL CHUTE DEFLECTOR REMOTE CONTROL (See Figs. 8 and 9)

1. Install remote cable bracket to discharge chute with 5/16-18 carriage bolt and 5/16-18 locknut as shown. Tighten securely.
2. Install remote cable eyelet to chute deflector with 1/4-20 shoulder bolt, nylon washer and 1/4-20 locknut as shown. Tighten securely.
3. Install spring hooks between hex nuts on chute rotator head and into hole in chute deflector as shown.

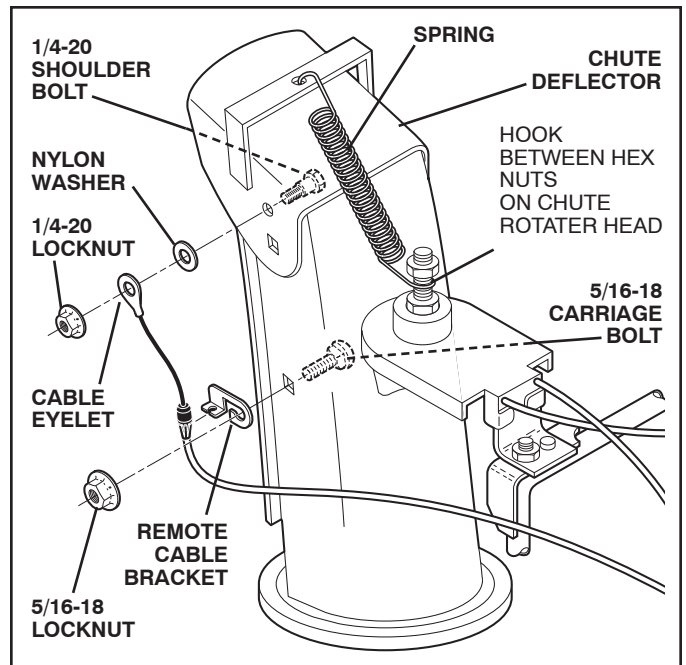

FIG. 8

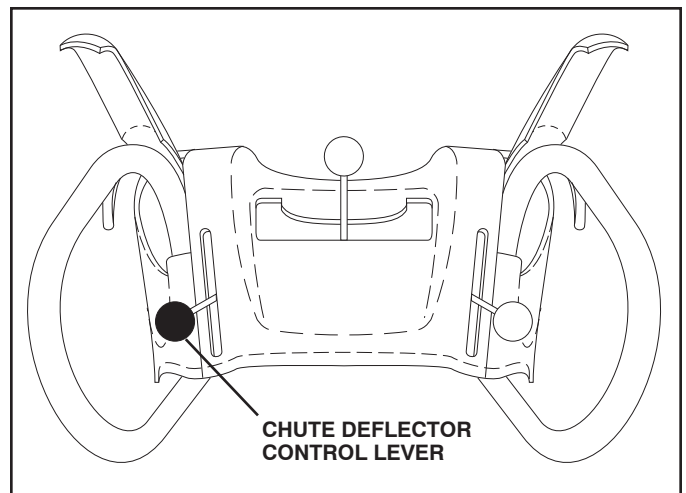

FIG. 9

## CHECK TIRE PRESSURE

The tires on your snow thrower were overinflated at the factory for shipping purposes. Correct and equal tire pressure is important for best snow throwing performance.

- Reduce tire pressure to 14-17 PSI (19-24.5 N-m).



# OPERATION

## KNOW YOUR SNOW THROWER

READ THIS OWNER'S MANUAL AND ALL SAFETY RULES BEFORE OPERATING YOUR SNOW THROWER. Compare the illustrations with your snow thrower to familiarize yourself with the location of various controls and adjustments. Save this manual for future reference.

These symbols may appear on your snow thrower or in literature supplied with the product. Learn and understand their meaning.

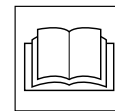

READ AND FOLLOW ALL SAFETY INFORMATION AND INSTRUCTIONS BEFORE USE OF THIS PRODUCT. KEEP THESE INSTRUCTIONS FOR FUTURE REFERENCE.

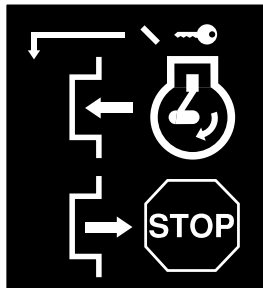

IGNITION KEY.  
INSERT TO START  
AND RUN,  
PULL OUT TO STOP.

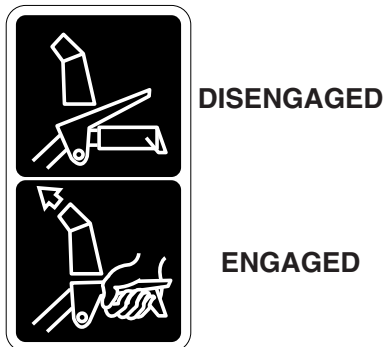

SNOW  
DISCHARGE

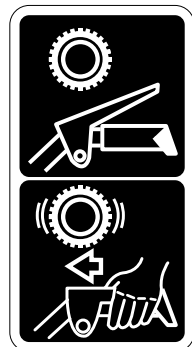

TRACTION  
DRIVE CONTROL



# OPERATION

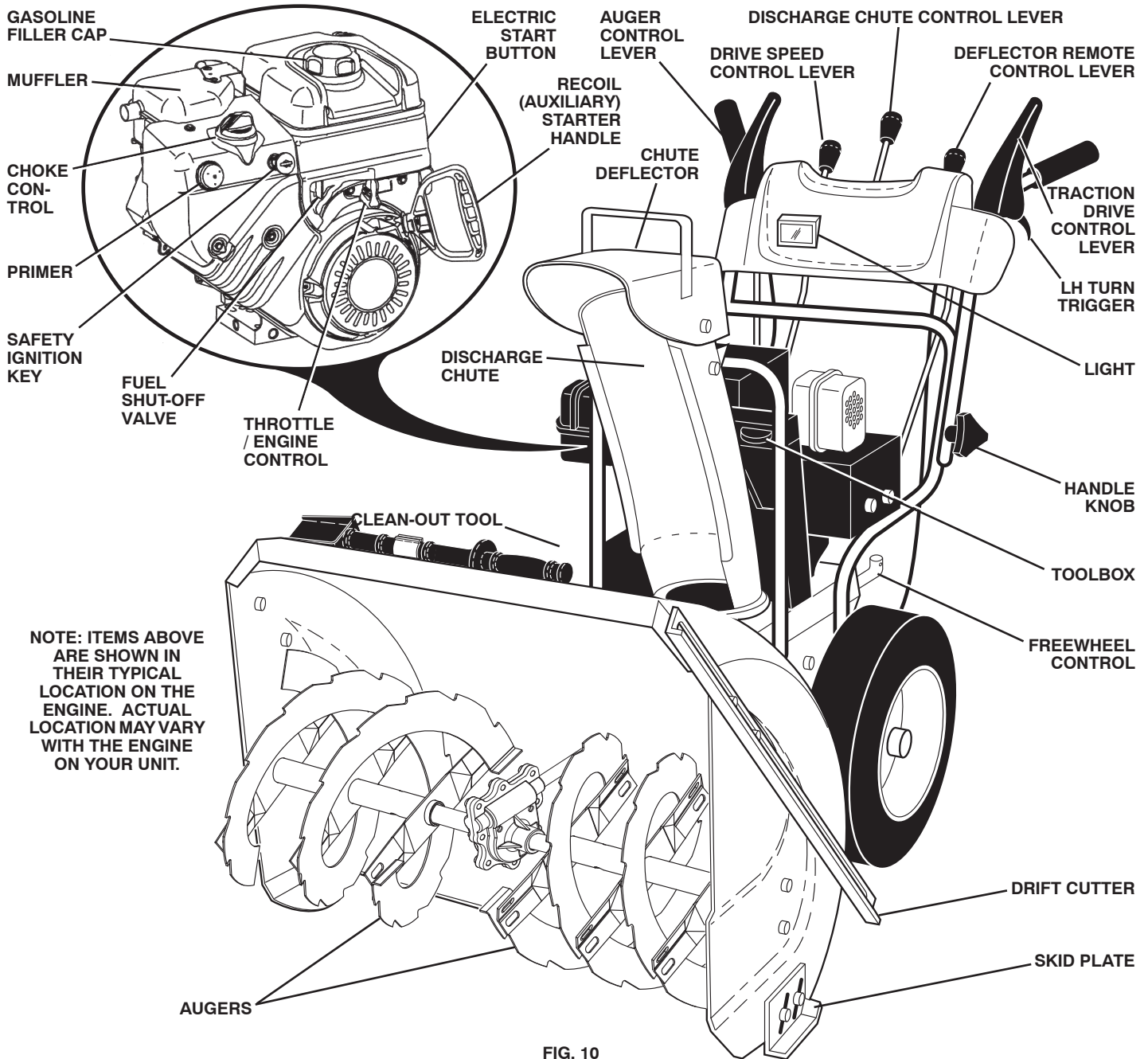

FIG. 10

## MEETS A.N.S.I. SAFETY REQUIREMENTS

Our snow throwers conform to the standards of the American National Standards Institute.

**Toolbox** – used to store spare shear bolts, locknuts and wrench.

**Safety ignition key** - must be inserted for the engine to start and run. Remove when snow thrower is not in use.

**Electric start button** – used for starting the engine.

**Recoil (auxiliary) starter handle** – used for starting engine.

**Primer** – pumps additional fuel from the carburetor to the cylinder for use when starting a cold engine.

**Choke Control** – used for starting a cold engine.

**Throttle / Engine control** – used to select either FAST or SLOW engine speed and to STOP the engine.

**Freewheel control** – disengages transmission for pushing the snowthrower with the engine off.

**LH and RH turn triggers** – used to steer the snow thrower.

**Drive speed control lever** – used to select forward or reverse motion and speed of snow thrower.

**Traction drive control lever** – used to engage power-propelled forward or reverse motion of snow thrower.

**Auger control lever** – used to engage auger motion (throw snow).

**Discharge chute control lever** – used to change the direction the snow is thrown.

**Deflector remote control lever** – used to change the distance the snow is thrown.

**Skid plate** – used to adjust height of scraper bar from ground.

10 **Drift cutter** – used to cut through deep snowdrifts.

# OPERATION



The operation of any snow thrower can result in foreign objects thrown into the eyes, which can result in severe eye damage. Always wear safety glasses or eye shields while operating your snow thrower or performing any adjustments or repairs. We recommend standard safety glasses or a wide vision safety mask worn over spectacles.

## HOW TO USE YOUR SNOW THROWER

**Know how** to operate all controls before adding fuel or attempting to start the engine.

### STOPPING

#### TRACTION DRIVE

- Release traction drive control lever to stop the forward or reverse movement of the snow thrower.

#### AUGER

- Release the auger control lever to stop throwing snow.

#### ENGINE

- Move throttle control to "STOP" position.
- Remove (do not turn) safety ignition key to prevent unauthorized use.

**NOTE:** Never use choke to stop engine.

### TO USE FUEL SHUT-OFF VALVE (See Fig. 11)

The fuel shut-off valve is located beneath the fuel tank on the engine. Always operate the snow thrower with the fuel shut-off valve in the OPEN position.

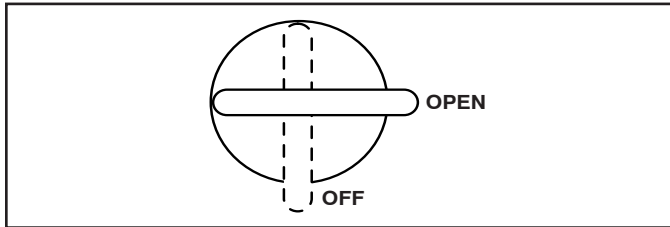

FIG. 11

### TO USE THROTTLE CONTROL (See Fig. 12)

The throttle control is located on the engine. Always operate the snow thrower with the engine at full throttle. Full throttle offers the best snow thrower performance.

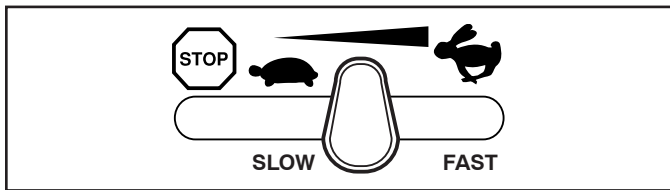

FIG. 12

### TO USE CHOKE CONTROL (See Fig. 13)

The choke control is located on the engine. Use the choke control whenever you are starting a cold engine. Do not use to start a warm engine.

- To engage choke, turn knob counterclockwise. Slowly turn knob clockwise to disengage.

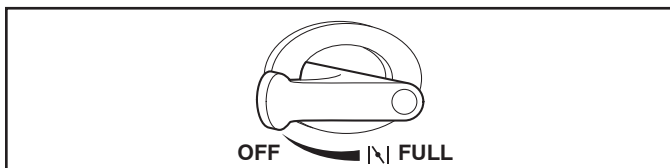

FIG. 13

### TO CONTROL SNOW DISCHARGE (See Fig. 14)



**WARNING:** Snow throwers have exposed rotating parts, which can cause severe injury from contact, or from material thrown from the discharge chute. Keep the area of operation clear of all persons, small children and pets at all times including startup.



**WARNING:** If the discharge chute or auger become clogged, shut-off engine and wait for all moving parts to stop. Use the clean-out tool, NOT YOUR HANDS, to unclog the chute and/or auger.

The DIRECTION in which snow is to be thrown is controlled by the discharge chute control lever.

- To change the discharge chute position, press downward on discharge chute control lever and move lever left or right until chute is in desired position. Be sure lever springs back and locks into desired position.

The DISTANCE that snow is thrown is controlled by the position of the chute deflector. Set the deflector low to throw snow a short distance; set the deflector higher to throw snow farther.

- Press downward on chute deflector control lever and move lever forward to lower the deflector and decrease the distance. Move lever back to raise the deflector and increase the distance. Be sure lever springs back and locks into desired position.

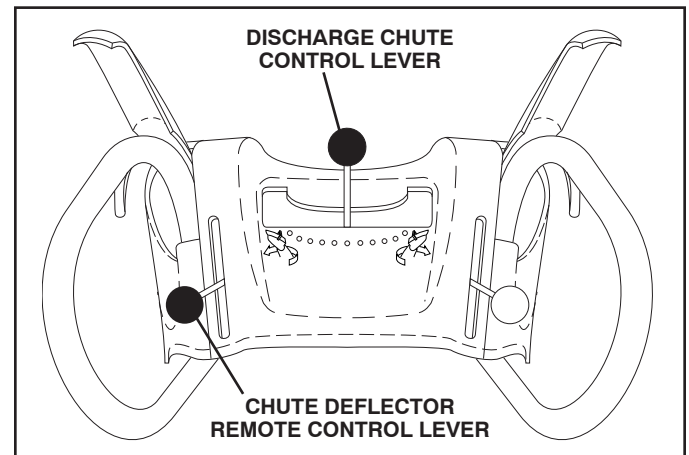

FIG. 14

### TO THROW SNOW (See Fig. 15)

The auger rotation is controlled by the auger control lever located on the right side handle.

- Squeeze auger control lever to handle to engage the auger and throw snow.
- Release the auger control lever to stop throwing snow.

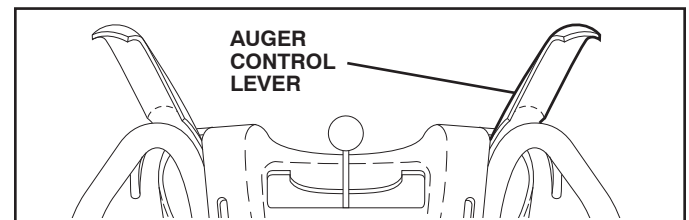

FIG. 15

# OPERATION

## USING THE CLEAN-OUT TOOL (See Fig. 16)

In certain snow conditions, the discharge chute may become clogged with ice and snow. Use the clean-out tool to dislodge this blockage.

**When cleaning, repairing, or inspecting, make certain all controls are disengaged and the auger/impeller and all moving parts have stopped. Disconnect the spark plug wire and keep the wire away from the spark plug to prevent accidental starting.**

- Release the auger control lever and shut off the engine.
- Remove the clean-out tool from its mounting clip. Grasp the tool firmly by the handle and push and twist the tool into the discharge chute to dislodge the blockage.

After the packed snow has been dislodged, return the clean-out tool to its mounting clip by pushing it into the clip.

- Make sure the discharge chute is pointed in a safe direction (no vehicles, buildings, people, or other objects are in the direction of discharge) before restarting the engine.
- Restart the engine, then squeeze the auger control lever to the handle to clear snow from the auger housing and the discharge chute.

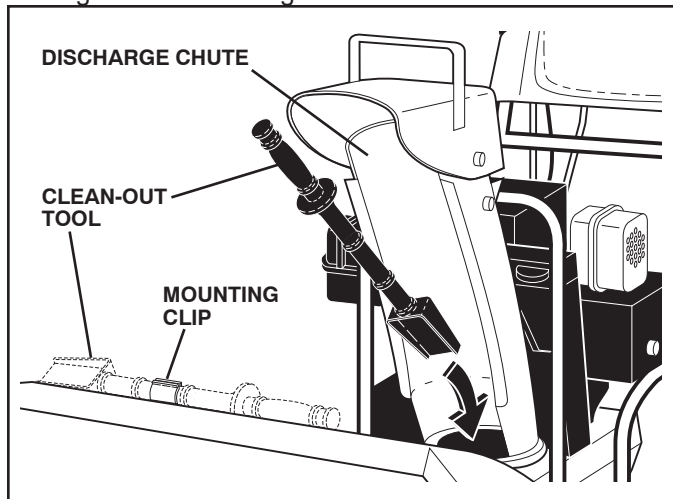

FIG. 16

## TO MOVE FORWARD AND BACKWARD (See Fig. 17)

SELF-PROPELLING, forward and reverse movement of the snow thrower, is controlled by the traction drive control lever located on the left side handle.

- Squeeze traction drive control lever to handle to engage the drive system.
- Release traction drive control lever to stop the forward or reverse movement of the snow thrower.

SPEED and DIRECTION are controlled by the drive speed control lever.

- Move speed control lever to desired position AFTER engaging the traction drive control lever.

**CAUTION: Do not move speed control lever unless engine is running. Damage to the snow thrower can result.**

- Slower speeds are for heavier snow and faster speeds are for light snow and transporting the snow thrower. It is recommended that you use a slower speed until you are familiar with the operation of the snow thrower.

**NOTE:** When both traction drive and auger control levers are engaged, the traction drive control lever will lock the auger control lever in the engaged position. This will allow you to release your right hand from the handle and adjust the discharge chute direction without interrupting the snow throwing process.

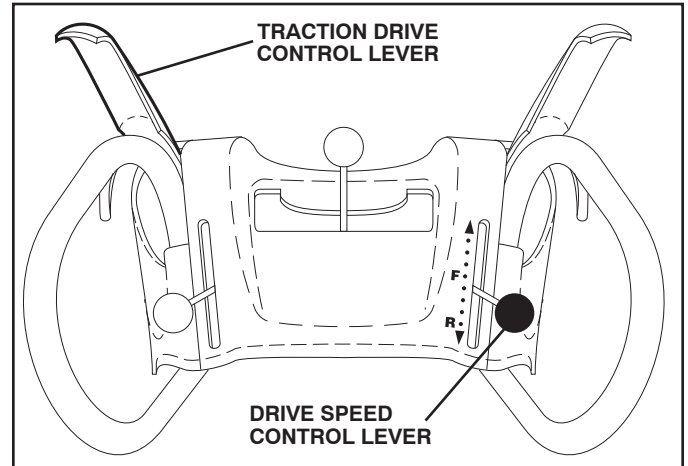

FIG. 17

## POWER STEERING OPERATION (See Fig. 18)

Steering triggers are used to assist in steering your snow thrower. The triggers are located on the underside of each handle. When a trigger is squeezed, it disengages the drive wheel on that side of snow thrower and allows it to turn in that direction.

- To turn left – squeeze left side trigger.
- To turn right – squeeze right side trigger.

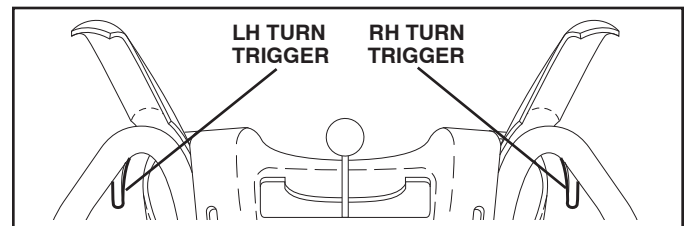

FIG. 18

## TO ADJUST SKID PLATES (See Fig. 19)

**NOTE:** The wrench provided in your parts bag may be used to adjust the skid plates.

Skid plates are located on each side of the auger housing and adjust the clearance between the scraper bar and the ground surface. Adjust skid plates evenly to proper height for current surface conditions. For removal of snow in normal conditions, such as a paved driveway or sidewalk, place skid plates in the highest position (lowest scraper clearance) to give a 5 mm clearance between the scraper bar and the ground. Use a middle position if the surface to be cleared is uneven.

**NOTE:** It is not recommended to operate the snow thrower over gravel or rocky surfaces. Objects such as gravel, rocks or other debris, can easily be picked up and thrown by the impeller, which can cause serious personal injury, property damage or damage to the snow thrower.

# OPERATION

- If snow thrower must be operated over gravel surface, use extra caution and be sure skid plates are adjusted to lowest (highest scraper clearance) position.
- Shut off engine and wait for all moving parts to stop.
  - Adjust skid plates by loosening the 1/2" hex nuts, then moving skid plate to desired position. Be sure both plates are adjusted evenly. Tighten securely.

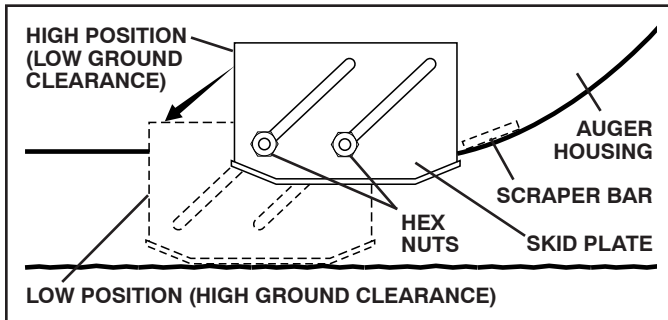

FIG. 19

## SCRAPER BAR (SEE FIG. 19)

The scraper bar is not adjustable, but is reversible. After considerable use it may become worn. When it has worn almost to the edge of the housing, it can be reversed, providing additional service before requiring replacement. Replace a damaged or worn scraper bar.

## TO USE DRIFT CUTTERS (See Fig. 20)

Use the drift cutters to cut through deep snowdrifts that are higher than the front of the snow thrower.

- Loosen upper adjustment nut enough to allow drift cutter to be raised to highest position and tighten nut securely. Repeat for opposite side of snow thrower.
- When not using drift cutters, loosen adjustment nut, lower to storage position and tighten nut securely.

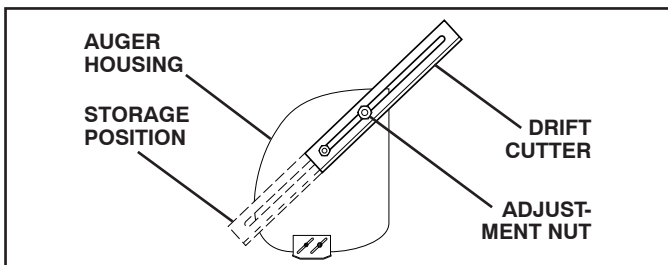

FIG. 20

## TO TRANSPORT (See Fig. 21)

When pushing or towing your snowthrower, be sure to disengage transmission by placing freewheel control into FREEWHEEL position. Freewheel control is located at the rear of snowthrower.

- Pull freewheel control out to FREEWHEEL position.
- To reengage transmission, push control back in.

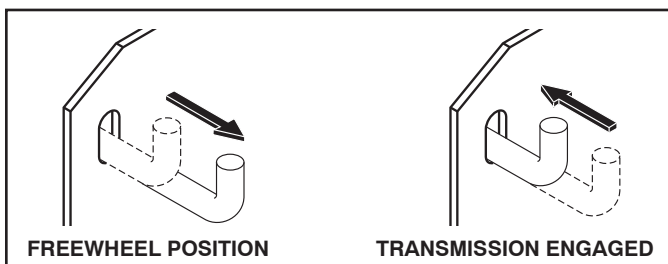

FIG. 21

## BEFORE STARTING THE ENGINE

### CHECK ENGINE OIL LEVEL (See Fig. 22)

The engine on your snow thrower has been shipped, from the factory, already filled with oil.

- Check engine oil with snow thrower on level ground.
  - Remove oil fill cap/dipstick and wipe clean, reinsert the dipstick and screw tight, wait for a few seconds, remove and read oil level. If necessary, add oil until "FULL" mark on dipstick is reached. Do not overfill.
- To change engine oil, see "TO CHANGE ENGINE OIL" in the Maintenance section of this manual.

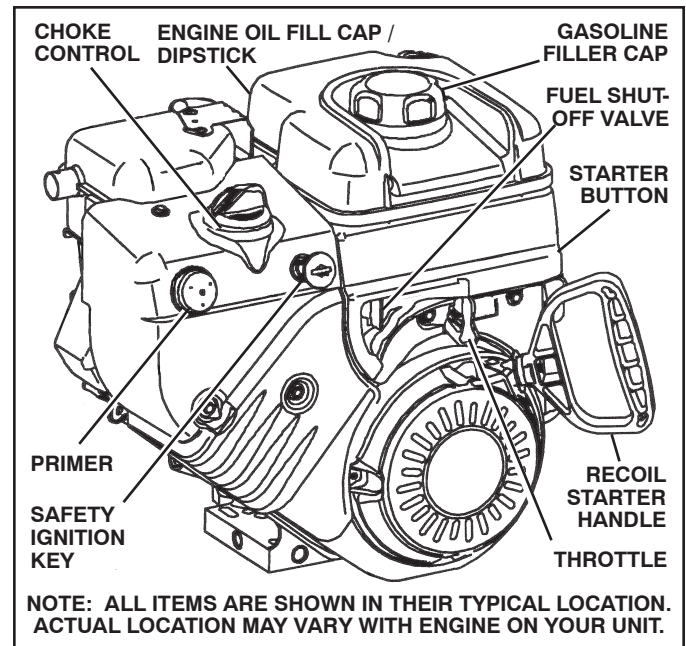

FIG. 22

## ADD GASOLINE (See Fig. 22)

- Fill fuel tank to bottom of tank filler neck. Do not overfill. Use fresh, clean, regular unleaded gasoline with a minimum of 87 octane. Do not mix oil with gasoline. Purchase fuel in quantities that can be used within 30 days to assure fuel freshness.



**WARNING:** Wipe off any spilled oil or fuel. Do not store, spill or use gasoline near an open flame.

**CAUTION:** Alcohol blended fuels (called gasohol or using ethanol or methanol) can attract moisture which leads to separation and formation of acids during storage. Acidic gas can damage the fuel system of an engine while in storage. To avoid engine problems, the fuel system should be emptied before storage of 30 days or longer. Empty the gas tank, start the engine and let it run until the fuel lines and carburetor are empty. Use fresh fuel next season. See Storage Instructions for additional information. Never use engine or carburetor cleaner products in the fuel tank or permanent damage may occur.

# OPERATION

## TO START ENGINE

- Be sure fuel shut-off valve is in the “OPEN” position.

Your snow thrower engine is equipped with both a 120 Volt A.C. electric starter and a recoil starter. The electric starter is equipped with a three-wire power cord and plug and is designed to operate on 120 Volt A.C. household current.

- Be sure your house is a 120 Volt A.C. three-wire grounded system. If you are uncertain, consult a licensed electrician.



**WARNING: Do not use the electric starter if your house is not a 120 Volt A.C. three-wire grounded system. Serious personal injury or damage to your snow thrower could result.**

## COLD START - ELECTRIC STARTER

1. Insert safety ignition key (packed separately in parts bag) into ignition slot until it clicks. DO NOT turn the key. Keep the extra safety ignition key in a safe place.
2. Place throttle control in “FAST” position.
3. Rotate choke control to “FULL” position.
4. Connect the power cord to the engine.
5. Plug the other end of the power cord into a three-hole grounded 120 Volt A.C. receptacle.

**NOTE:** Do not use primer when starting engine with the electric starter.

6. Push starter button until engine starts.

**IMPORTANT:** Do not crank engine more than five continuous seconds between each time you try to start. Wait 5 to 10 seconds between each attempt.

7. When the engine starts, release the starter button and slowly move the choke control to the “OFF” position.
8. Disconnect the power cord from the receptacle first, then from the engine.

Allow the engine to warm up for a few minutes. Engine will not develop full power until it has reached normal operating temperature.

## WARM START - ELECTRIC STARTER

Follow the steps above, keeping the choke control in the “OFF” position.

## COLD START - RECOIL STARTER

1. Insert safety ignition key (packed separately in parts bag) into ignition slot until it clicks. DO NOT turn the key. Keep the extra safety ignition key in a safe place.
2. Place throttle control in “FAST” position.
3. Rotate choke control to “FULL” position.
4. Push the primer four (4) times if the temperature is below 15°F, or two (2) times if temperature is between 15° and 50°F. If temperature is above 50°F, priming is not necessary.

**NOTE:** Over priming may cause flooding, preventing the engine from starting. If you do flood the engine, wait a few minutes before attempting to start and DO NOT push the primer.

5. Pull recoil starter handle quickly. Do not allow starter rope to snap back.
6. When the engine starts, release the recoil starter handle and slowly move the choke control to the “OFF” position.

Allow the engine to warm up for a few minutes. Engine will not develop full power until it has reached normal operating temperature.

## WARM START - RECOIL STARTER

Follow the steps above, keeping the choke in the “OFF” position. DO NOT push the primer.

## BEFORE STOPPING

Run the engine for a few minutes to help dry off any moisture on the engine.

To avoid possible freeze-up of the starter, proceed as follows:

## ELECTRIC STARTER

1. Connect the power cord to the engine.
2. Plug the other end of the power cord into a three-hole grounded 120 Volt A.C. receptacle.
3. While the engine is running, push starter button and spin the starter for several seconds.

**NOTE:** The unusual sound made while starter is spinning will not harm the engine or starter.

4. Disconnect the power cord from the receptacle first, then from the engine.

## RECOIL STARTER

1. While the engine is running, pull the recoil starter handle with rapid, full arm strokes three or four times.

**NOTE:** The unusual sound made while pulling the recoil starter handle will not harm the engine or starter.

## IF RECOIL STARTER HAS FROZEN

If the recoil starter has frozen and will not turn the engine, proceed as follows:

1. Grasp the recoil starter handle and slowly pull as much rope out of the starter as possible.
2. Release the recoil starter handle and let it snap back against the starter.

If the engine still fails to start, repeat the above steps or use the electric starter.

# MAINTENANCE

<b>MAINTENANCE SCHEDULE</b>		BEFORE EACH USE						AFTER EACH USE						EVERY 25 HOURS OR EVERY SEASON						EVERY 50 HOURS						EVERY 100 HOURS						BEFORE STORAGE						SERVICE DATES					
		THROWER		ENGINE		THROWER		ENGINE		THROWER		ENGINE		THROWER		ENGINE		THROWER		ENGINE		THROWER		ENGINE		THROWER		ENGINE		THROWER		ENGINE											
Check for Loose Fasteners		✓																																									
Clean / Inspect Snow Thrower				✓																																							
Check / Replace V-Belts								✓																																			
Lubrication Chart						✓								✓																													
Check Engine Oil Level		✓																																									
Change Engine Oil						✓																																					
Inspect Muffler								✓																																			
Check / Replace Spark Plug										✓																																	
Empty Fuel Tank												✓																															

## GENERAL RECOMMENDATIONS

The warranty on this snow thrower does not cover items that have been subjected to operator abuse or negligence. To receive full value from the warranty, operator must maintain snow thrower as instructed in this manual. Some adjustments will need to be made periodically to properly maintain your snow thrower.

At least once a season, check to see if you should make any of the adjustments described in the Service and Adjustments section of this manual.

- At least once a year, you should replace the spark plug and check belts for wear. A new spark plug will help your engine run better and last longer.
- Follow the maintenance schedule in this manual.

**NOTE:** Use only Original Equipment Manufacturer (OEM) parts to service this unit. Failure to do so can cause the unit to malfunction and pose a risk of injury to the operator.

## BEFORE EACH USE

1. Check engine oil level.
2. Check for loose fasteners.
3. Check controls to be sure they are functioning properly.

## LUBRICATION

Keep your snow thrower well lubricated (See "LUBRICATION CHART").

## LUBRICATION CHART

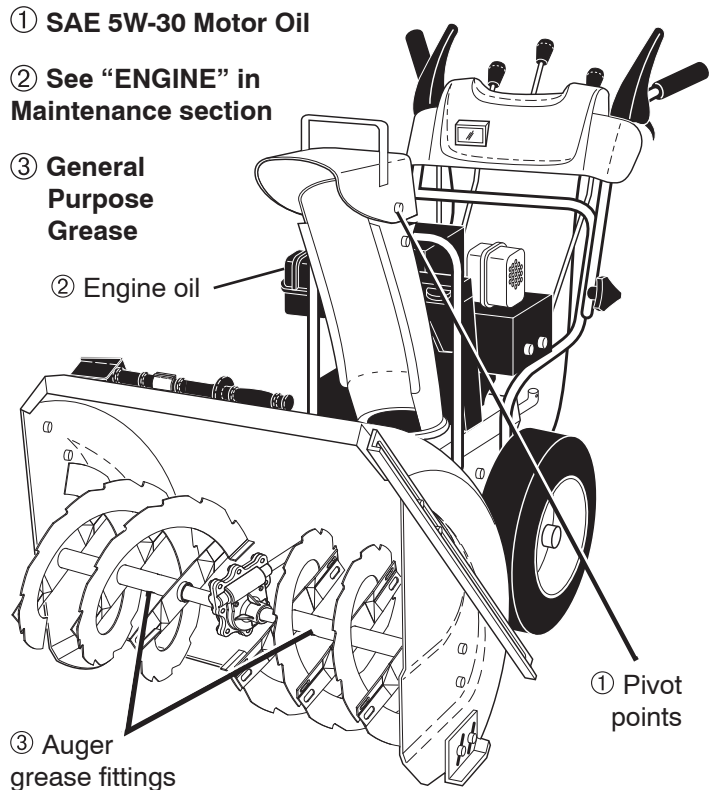

## SNOW THROWER

Always observe the safety rules when performing any maintenance.

## TIRES

- Maintain proper air pressure in both tires (14–17 P.S.I. / 19-24.5 N-m).

- Keep tires free of gasoline and oil, which can harm rubber.

**NOTE:** To seal tire punctures and prevent flat tires due to slow leaks, tire sealant may be purchased from your local parts dealer. Tire sealant also prevents tire dry rot and corrosion.

# MAINTENANCE

## V-BELTS

Check V-belts for deterioration and wear after every 50 hours of operation and replace if necessary. The belts are not adjustable. Replace belts if they begin to slip from wear. (See "TO REMOVE BELT COVER" in the Service and Adjustments section of this manual).

The V-belts on your snow thrower are of special construction and should be replaced by original equipment manufacturer (OEM) belts available from your nearest dealer. Using other than OEM belts can cause personal injury or damage to the snow thrower.

## AUGER GEAR CASE

- The gear case was filled with lubricant to the proper level at the factory. The only time the lubricant needs attention is if service has been performed on the gear case.
- If lubricant is required, use only Ronex ED #1 grease.

## TRACTION DRIVE SYSTEM

DO NOT lubricate the drive components inside the snow thrower. The bearings and bushings are lifetime lubricated and require no maintenance.

## ENGINE

### LUBRICATION

Use only high quality detergent oil rated with API service classification SG–SL. Select the oil's SAE viscosity grade according to your expected operating temperature.

SAE VISCOSITY GRADES					
°F	-20	0	30	32	40
°C	-30	-20	-10	0	10
TEMPERATURE RANGE ANTICIPATED BEFORE NEXT OIL CHANGE					

← **Synthetic 5W30 or 10W30**

**5W30 or 10W30**

**NOTE:** Although multi-viscosity oils (5W30, 10W30 etc.) improve starting in cold weather, these multi-viscosity oils will result in increased oil consumption when used above 32°F. Check your engine oil level more frequently to avoid possible engine damage from running low on oil.

Change the oil after every 25 hours of operation or at least once a year if the snow thrower is not used for 25 hours in one year.

Check the crankcase oil level before starting the engine and after each five (5) hours of continuous use. Tighten oil fill cap / dipstick securely each time you check the oil level.

### TO CHANGE ENGINE OIL

Determine temperature range anticipated before next oil change. All oil must meet API service classification SG–SL.

- Be sure snow thrower is on level surface.
- Oil will drain more freely when warm.
- Catch oil in a suitable container.

**NOTE:** The left side wheel may be removed from snow thrower for easier access to the oil drain plug and placement of a suitable container. The unit tilted, resting on the frame with the left wheel removed, will help drain any oil trapped inside the engine. (See "TO REMOVE WHEELS" in the Service and Adjustments section of this manual).

1. Remove safety ignition key and disconnect spark plug wire from spark plug. Place wire where it cannot come in contact with spark plug.
2. Clean area around drain plug.
3. Remove drain plug and drain oil in a suitable container.
4. Install drain plug and tighten securely.
5. Wipe off any spilled oil from snow thrower and engine.
6. Install left wheel (if removed for draining oil). Be sure to install klick pin into proper hole in wheel axle (See "TO REMOVE WHEELS" in the Service and Adjustments section of this manual).
7. Remove oil fill cap/dipstick. Be careful not to allow dirt to enter the engine.
8. Refill engine with oil through oil dipstick tube. Pour slowly. Do not overfill. For approximate capacity see "PRODUCT SPECIFICATIONS" section of this manual.
9. Use gauge on oil fill cap/dipstick for checking level. Be sure dipstick cap is tightened securely for accurate reading. Keep oil at "FULL" line on dipstick.
10. Wipe off any spilled oil.

## MUFFLER

Inspect and replace corroded muffler as it could create a fire hazard and/or damage.

## SPARK PLUG

Replace spark plug at the beginning of each season or after every 100 hours of operation, whichever occurs first. Spark plug type and gap setting are shown in the "PRODUCT SPECIFICATIONS" section of this manual.

## CLEANING

**IMPORTANT:** For best performance, keep snow thrower housing free of any dirt or trash. Clean the outside of your snow thrower after each use.



**WARNING: Remove safety ignition key and disconnect spark plug wire from spark plug. Place wire where it cannot come in contact with spark plug.**

- Keep finished surfaces/wheels free of gasoline, oil, etc.
- We do not recommend using a garden hose to clean your snow thrower unless the electrical system, muffler and carburetor are covered to keep water out. Water in engine can result in shortened engine life.



# SERVICE AND ADJUSTMENTS

**WARNING:** To avoid serious injury, before performing any service or adjustments:



1. Be sure throttle is in STOP position.
2. Remove safety ignition key.
3. Make sure the augers and all moving parts have completely stopped.
4. Disconnect spark plug wire from spark plug and place wire where it cannot come in contact with plug.

## SNOW THROWER

### TO ADJUST SNOW THROWER HEIGHT

See "TO ADJUST SKID PLATES" and "SCRAPER BAR" in the Operation section of this manual.

### CHUTE DEFLECTOR

The chute deflector, attached to the top of the discharge chute, is provided to direct discharging snow away from the operator. If the deflector becomes damaged, it should be replaced.



**WARNING:** To avoid serious injury, never operate your snow thrower with the deflector removed or damaged.

- To change direction and/or distance snow is discharged, see "TO CONTROL SNOW DISCHARGE" in the Operation section of this manual.

### SHEAR BOLTS (See Fig. 23)

#### AUGER SHEAR BOLTS

Both right and left-hand augers are secured to the auger shaft with a spacer/shear bolt and hex nut. Should a foreign object or ice become lodged in the augers, the shear bolts are designed to break, preventing damage to any other components. If one or both augers do not turn when auger control lever is engaged, check to see if one or both of the bolts have sheared. To replace the shear bolts:

1. Disengage all controls and move throttle control to STOP position. Wait for all moving parts to stop.
2. Remove safety ignition key and disconnect spark plug wire from spark plug. Place wire where it cannot come in contact with spark plug.
3. Align hole in auger hub with hole in auger shaft and install a new 1/4-20 x 2" spacer/shear bolt and spacer. Install 1/4-20 lock nut and tighten securely.

**CAUTION:** Do not substitute. Use only original equipment shear bolts as supplied with your snow thrower.

4. Insert safety ignition key and reconnect spark plug wire to spark plug.

#### IMPELLER SHEAR BOLTS

The impeller is secured to the impeller shaft with two (2) capscrew/shear bolts and hex nuts. Should a foreign object or ice become lodged in the impeller, the capscrews are designed to break, preventing damage to any other components. If impeller does not turn when auger control lever

is engaged, check to see if the capscrews have sheared. To replace the capscrew/shear bolts:

1. Disengage all controls and move throttle control to STOP position. Wait for all moving parts to stop.
2. Remove safety ignition key and disconnect spark plug wire from spark plug. Place wire where it cannot come in contact with spark plug.
3. Align holes in impeller hub with holes in impeller shaft and install two (2) new 1/4-20 x 1-5/8" capscrew/shear bolts. Install 1/4-20 locknuts and tighten securely.

**CAUTION:** Do not substitute. Use only original equipment capscrew/shear bolts as supplied with your snow thrower.

4. Insert safety ignition key and reconnect spark plug wire to spark plug.

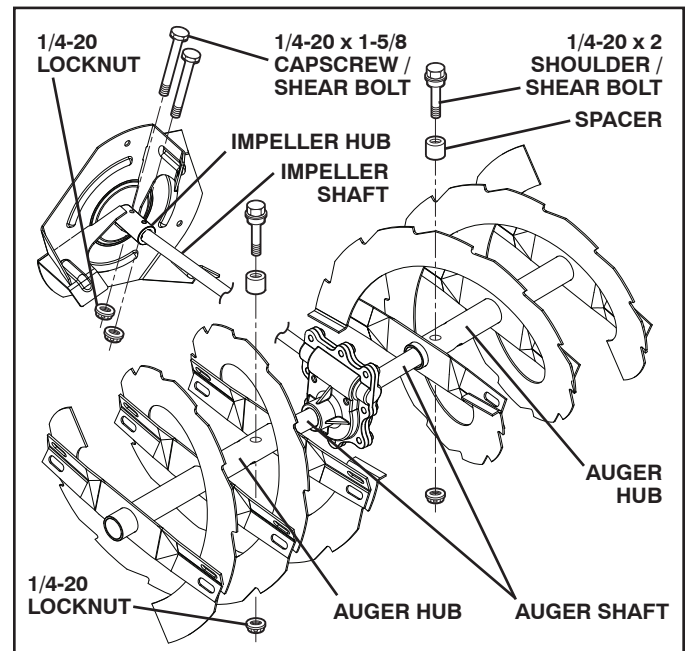

FIG. 23

### TO REMOVE BELT COVER (See Fig. 24)

1. Remove the two (2) screws securing belt cover to frame.
  2. Remove belt cover.
- Replace belt cover by installing cover and screws and tighten securely.

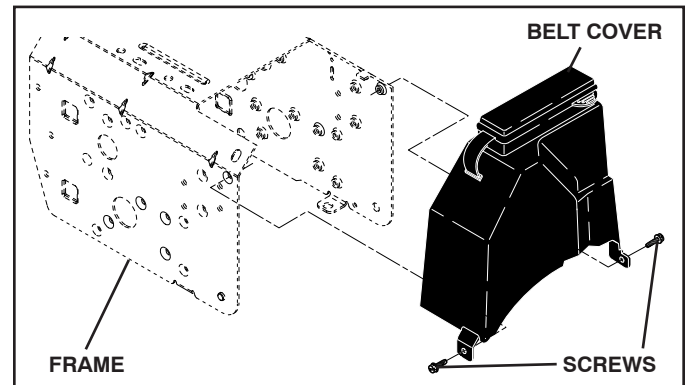

FIG. 24

# SERVICE AND ADJUSTMENTS

## TO REPLACE BELTS (See Fig. 25)

The auger and traction drive belts are not adjustable. If the belts are damaged or begin to slip from wear, they should be replaced. It is recommended that the belt(s) be replaced by a Sears service centre/department.

**NOTE:** It is recommended that both the auger and traction drive belt be replaced at the same time.

The V-belts on your snow thrower are of special construction and should be replaced by original equipment manufacturer (OEM) belts available from your nearest Sears service centre/department. Using other than OEM belts can cause personal injury or damage to the snow thrower.

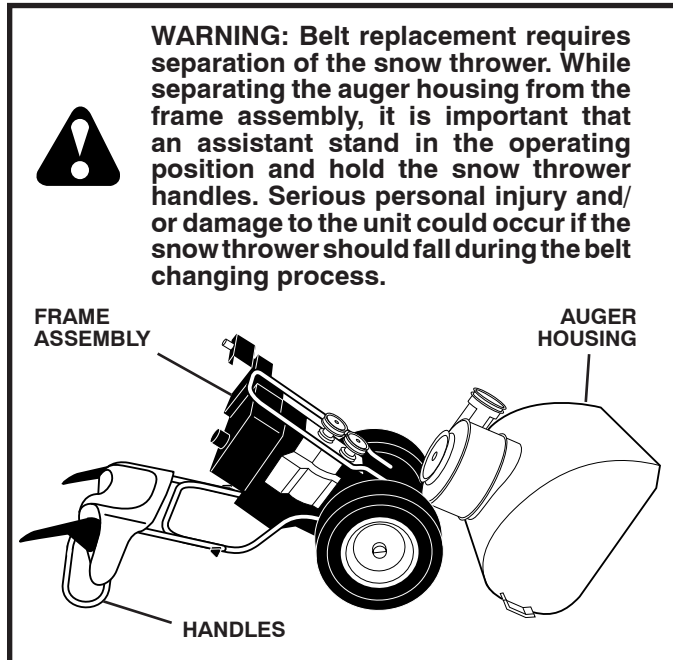

1. REMOVE GASOLINE FROM FUEL TANK - Drain gasoline from fuel tank into a suitable container, outdoors, away from fire or flame. Wipe up any spilled gasoline.
2. REMOVE DISCHARGE CHUTE - Loosen locknut securing chute rotator head to mounting bracket only enough to allow chute rotator head to be raised and discharge chute to be removed from snow thrower.
3. REMOVE BELT COVER - See "TO REMOVE BELT COVER" in this section of this manual.
4. REMOVE ENGINE PULLEY - Remove bolt, lockwasher and flat washer securing pulley to engine crankshaft. Remove outside (auger) pulley only from crankshaft.
5. SEPARATE SNOW THROWER - With your assistant standing in the operating position holding the handles, remove the two (2) bolts holding auger housing and frame together.



6. REMOVE AUGER BELT from around pulley.
7. RELIEVE TENSION ON TRACTION DRIVE BELT IDLER and remove traction drive belt from around pulleys.

**HINT:** Insert a 3/8" drive ratchet (in the "ON" position) into the square hole in idler arm and rotate ratchet clockwise to relieve tension.

8. With tension relieved on idler, install new traction drive belt around pulleys and inside belt keepers.
9. Place auger belt around and inside the groove of auger pulley only.
10. While your assistant slowly raises handles to rejoin the auger housing and frame assembly, pull up on the auger belt and squeeze sides together above pulley so belt is fully seated in groove of pulley.
11. Move idler arm so it does not hit impeller pulley as you bring snow thrower completely together and check carefully for proper routing of belts. If auger belt has become dislodged from the pulley (by catching the idler arm bracket while bringing snow thrower together), separate the snow thrower and repeat step 12. Belt must be fully seated in pulley groove when bringing the snow thrower together.
12. Install the two (2) hex bolts and tighten securely.
13. INSTALL ENGINE PULLEY - Place belt in pulley groove and slide pulley on crankshaft. Install flat washer, lockwasher and bolt and tighten securely (41-47 N-m torque). Make sure belt is inside belt keeper.
14. INSTALL BELT COVER and two (2) screws. Tighten securely.
15. INSTALL DISCHARGE CHUTE - See "INSTALL DISCHARGE CHUTE / CHUTE ROTATER HEAD" in the Assembly / Pre-Operation section of this manual.

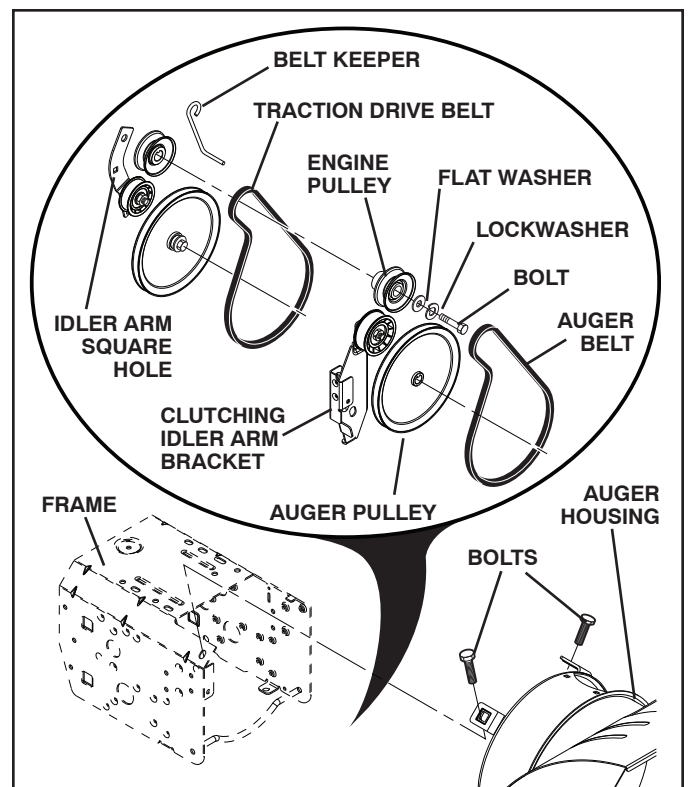

FIG. 25

## TO REMOVE WHEELS (See Fig. 26)

- Remove the klik pin and remove wheel from axle.

**IMPORTANT:** When installing wheel, be sure to use the axle hole closest to the end of the shaft – *do not* use the hole in the wheel hub (if equipped). Inner hole in axle and hole in wheel hub are not used for your model snow thrower.

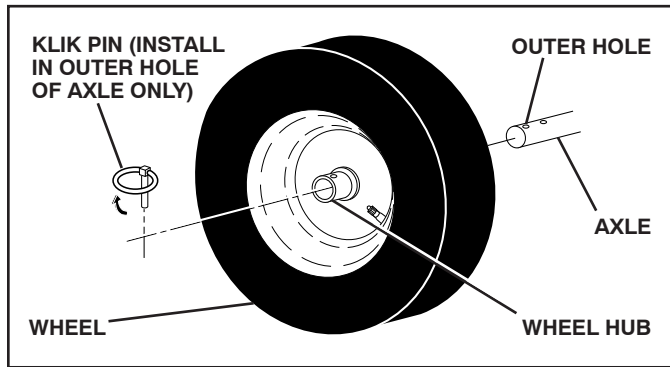

FIG. 26

**NOTE:** To seal punctures or prevent flat tires due to slow leaks, tire sealant may be purchased from your local parts dealer. Tire sealant also prevents tire dry rot and corrosion.

## ENGINE

### CARBURETOR

Your carburetor is not adjustable. Engine performance should not be affected at altitudes up to 2,134 meters. If your engine does not operate properly due to suspected carburetor problems, take your snow thrower to a Sears service centre/department.

### ENGINE SPEED

Never tamper with the engine governor, which is factory set for proper engine speed. Overspeeding the engine above the factory high speed setting can be dangerous and will void the warranty. If you think the engine-governed high speed needs adjusting, contact a Sears service centre/department, which has the proper equipment and experience to make any necessary adjustments.

# STORAGE

Immediately prepare your snow thrower for storage at the end of the season or if the unit will not be used for 30 days or more.



**WARNING:** Never store the snow thrower with gasoline in the tank inside a building where fumes may reach an open flame, spark or pilot light as on a furnace, water heater, clothes dryer or gas appliance. Allow the engine to cool before storing in any enclosure.

## SNOW THROWER

When snow thrower is to be stored for a period of time, clean it thoroughly, remove all dirt, grease, leaves, etc. Store in a clean, dry area.

1. Clean entire snow thrower (See "CLEANING" in the Maintenance section of this manual).
2. Inspect and replace belts, if necessary (See "TO REPLACE BELTS" in the Service and Adjustments section of this manual).
3. Lubricate as shown in the Maintenance section of this manual.
4. Be sure that all nuts, bolts, screws, and pins are securely fastened. Inspect moving parts for damage, breakage and wear. Replace if necessary.
5. Touch up all rusted or chipped paint surfaces; sand lightly before painting.

## ENGINE

### FUEL SYSTEM

**IMPORTANT:** It is important to prevent gum deposits from forming in essential fuel system parts such as carburetor, fuel hose, or tank during storage. Alcohol blended fuels (called gasohol or using ethanol or methanol) can attract moisture which leads to separation and formation of acids during storage. Acidic gas can damage the fuel system of an engine while in storage.

- Empty the fuel tank by starting the engine and letting it run until the fuel lines and carburetor are empty.
- Never use engine or carburetor cleaner products in the fuel tank or permanent damage may occur.
- Use fresh fuel next season.

**NOTE:** Fuel stabilizer is an acceptable alternative in minimizing the formation of fuel gum deposits during storage. Add stabilizer to gasoline in fuel tank or storage container. Always follow the mix ratio found on stabilizer container. Run engine at least 10 minutes after adding stabilizer to allow the stabilizer to reach the carburetor. Do not empty the gas tank and carburetor if using fuel stabilizer.

### ENGINE OIL

Drain oil (with engine warm) and replace with clean engine oil. (See "ENGINE" in the Maintenance section of this manual).

### CYLINDER

1. Remove spark plug.
2. Pour approximately one ounce (30 ml) of oil through spark plug hole into cylinder.
3. Pull recoil starter handle slowly a few times to distribute oil.
4. Replace with new spark plug.

### OTHER

- Remove safety ignition key; store it in a safe place.
- Do not store gasoline from one season to another.
- Replace your gasoline can if your can starts to rust. Rust and/or dirt in your gasoline will cause problems.
- If possible, store your snow thrower indoors and cover it to protect it from dust and dirt.
- Cover your snow thrower with a suitable protective cover that does not retain moisture. Do not use plastic. Plastic cannot breathe, which allows condensation to form and will cause your snow thrower to rust.

**IMPORTANT:** Never cover snow thrower while engine/exhaust area is still warm.

# TROUBLESHOOTING

See appropriate section in manual unless directed to a Sears service centre/department.

PROBLEM	CAUSE	CORRECTION
<b>Does not start</b>	<ol style="list-style-type: none"> <li>1. Fuel shut-off valve (if so equipped) in OFF position.</li> <li>2. Safety ignition switch OUT.</li> <li>3. Out of fuel.</li> <li>4. Throttle in STOP position.</li> <li>5. Choke in OFF position.</li> <li>6. Primer not depressed.</li> <li>7. Engine is flooded.</li> <li>8. Spark plug wire is disconnected.</li> <li>9. Bad spark plug.</li> <li>10. Stale fuel.</li> <li>11. Water in fuel.</li> </ol>	<ol style="list-style-type: none"> <li>1. Turn fuel shut-off valve to OPEN position.</li> <li>2. Push safety ignition switch IN.</li> <li>3. Fill fuel tank with fresh, clean gasoline.</li> <li>4. Move throttle to FAST position.</li> <li>5. Move to FULL position.</li> <li>6. Prime as instructed in the Operation section of this manual.</li> <li>7. Wait a few minutes before restarting, DO NOT prime.</li> <li>8. Connect wire to spark plug.</li> <li>9. Replace spark plug.</li> <li>10. Empty fuel tank &amp; carburetor, refill with fresh, clean gasoline.</li> <li>11. Empty fuel tank &amp; carburetor, refill with fresh, clean gasoline.</li> </ol>
<b>Loss of power</b>	<ol style="list-style-type: none"> <li>1. Spark plug wire loose.</li> <li>2. Throwing too much snow.</li> <li>3. Fuel tank cap is covered with ice or snow.</li> <li>4. Dirty or clogged muffler.</li> </ol>	<ol style="list-style-type: none"> <li>1. Reconnect spark plug wire.</li> <li>2. Reduce speed and width of swath.</li> <li>3. Remove ice and snow on and around fuel tank cap.</li> <li>4. Clean or replace muffler.</li> </ol>
<b>Engine idles or runs roughly</b>	<ol style="list-style-type: none"> <li>1. Choke is in FULL position.</li> <li>2. Blockage in fuel line.</li> <li>3. Stale fuel.</li> <li>4. Water in fuel.</li> <li>5. Carburetor is in need of adjustment or overhaul.</li> </ol>	<ol style="list-style-type: none"> <li>1. Move choke to OFF position.</li> <li>2. Clean fuel line.</li> <li>3. Empty fuel tank &amp; carburetor, refill with fresh, clean gasoline.</li> <li>4. Empty fuel tank &amp; carburetor, refill with fresh, clean gasoline.</li> <li>5. Contact a Sears service centre/department.</li> </ol>
<b>Excessive vibration</b>	<ol style="list-style-type: none"> <li>1. Loose parts or damaged augers or impeller.</li> </ol>	<ol style="list-style-type: none"> <li>1. Tighten all fasteners. Replace damaged parts. If vibration remains, contact a Sears service centre/department.</li> </ol>
<b>Recoil starter is hard to pull</b>	<ol style="list-style-type: none"> <li>1. Frozen recoil starter.</li> </ol>	<ol style="list-style-type: none"> <li>1. See "IF RECOIL STARTER HAS FROZEN" in the Operation section of this manual.</li> </ol>
<b>Loss of traction drive / slowing of drive speed</b>	<ol style="list-style-type: none"> <li>1. Drive belt is worn.</li> <li>2. Drive belt is off of pulley.</li> <li>3. Friction drive wheel is worn. (If so equipped)</li> </ol>	<ol style="list-style-type: none"> <li>1. Check / replace drive belt.</li> <li>2. Check / reinstall drive belt.</li> <li>3. Contact a Sears service centre/department.</li> </ol>
<b>Loss of snow discharge or slowing of snow discharge</b>	<ol style="list-style-type: none"> <li>1. Auger belt is off of pulley.</li> <li>2. Auger belt is worn.</li> <li>3. Clogged discharge chute.</li> <li>4. Augers / impeller jammed.</li> </ol>	<ol style="list-style-type: none"> <li>1. Check / reinstall auger belt.</li> <li>2. Check / replace auger belt.</li> <li>3. Clean snow chute.</li> <li>4. Remove debris or foreign object from augers / impeller.</li> </ol>

---

# SERVICE NOTES

---

# REPAIR PARTS

# SNOW THROWER - - MODEL NUMBER 944.528411

## AUGER HOUSING / IMPELLER ASSEMBLY

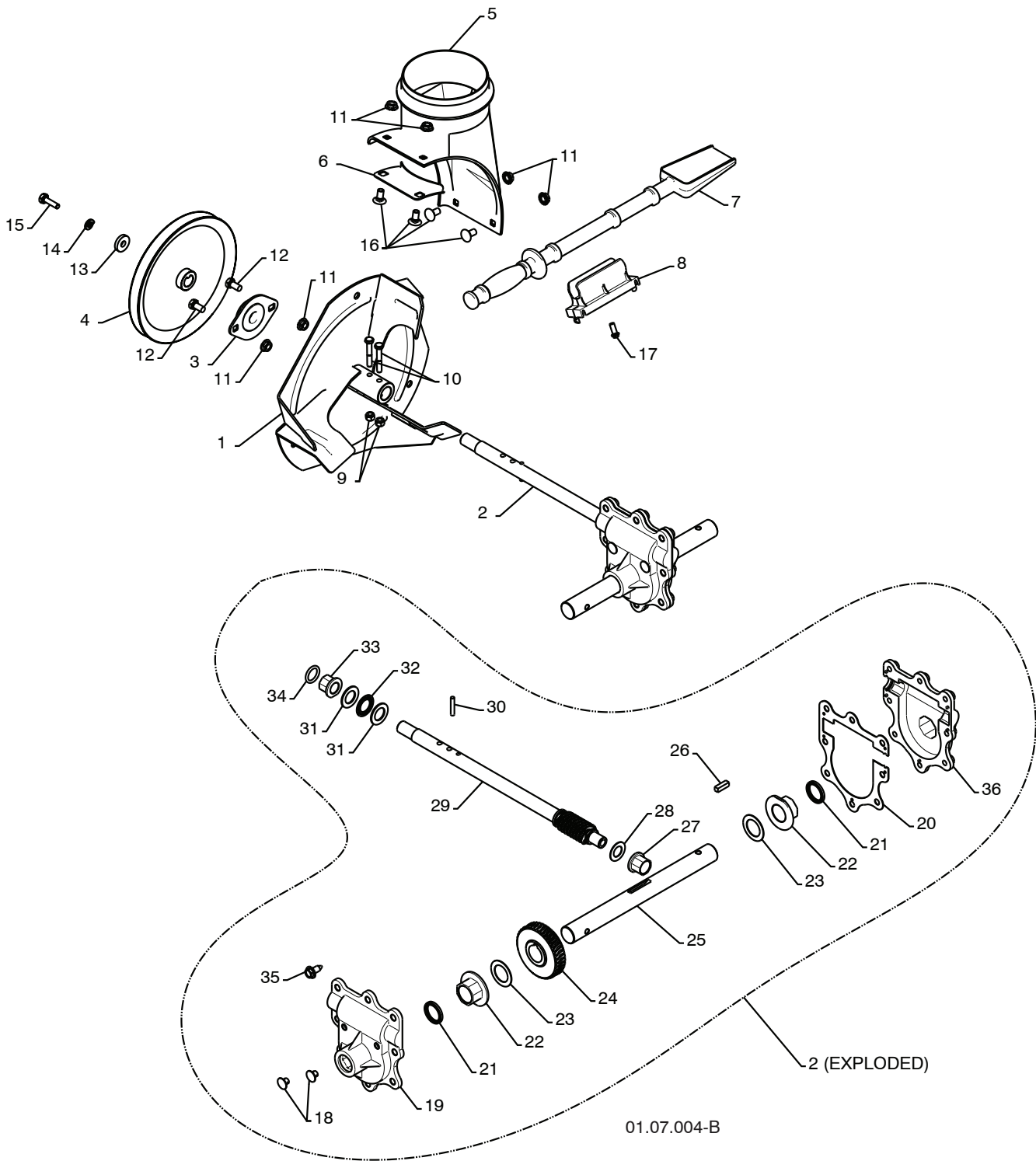

01.07.004-B

**NOTE:** All component dimensions given in U.S. inches. 1 inch = 25.4 mm  
**IMPORTANT:** Use only Original Equipment Manufacturer (O.E.M.) replacement parts.  
Failure to do so could be hazardous, damage your snow thrower and void your warranty.

**REPAIR PARTS****SNOW THROWER - - MODEL NUMBER 944.528411****AUGER HOUSING / IMPELLER ASSEMBLY**

<b>KEY NO.</b>	<b>PART NO.</b>	<b>DESCRIPTION</b>
1	175321X479	IMPELLER
2	196710	GEARBOX ASSEMBLY
3	188909	BEARING
4	191079	IMPELLER PULLEY
5	175322	DISCHARGE BASE
6	178675X008	CORNER BRACKET
7	192199	CLEAN OUT TOOL
8	405400	TOOL CLIP
9	73800400	NUT 1/4-20
10	74780426	SCREW 1/4-20 X .625
11	155377	NUT 5/16-18
12	163183	SCREW 5/16-18 X .625
13	19111507	WASHER
14	10040500	LOCKWASHER 5/16
15	74940516	SCREW 5/16-18 X 1.00
16	180355	CARRIAGE BOLT
17	194189	SCREW 13-16 X .625
18	407760	PLUG
19	407761	GEARBOX COVER RH
20	407766	GASKET
21	407770	SEAL
22	407762	BEARING
23	174697	THRUST WASHER 1.00
24	407763	WORM GEAR
25	407764	AUGER SHAFT
26	189282	SQUARE KEY
27	407758	BEARING
28	174683	THRUST WASHER
29	407757	IMPELLER SHAFT
30	7836M	ROLL PIN
31	174681	THRUST WASHER
32	174684	THRUST BEARING
33	407769	BEARING
34	407768	O-RING
35	407767	SCREW 5/16-18 X .750
36	407765	GEARBOX COVER LH

**NOTE:** All component dimensions given in U.S. inches. 1 inch = 25.4 mm

**IMPORTANT:** Use only Original Equipment Manufacturer (O.E.M.) replacement parts. Failure to do so could be hazardous, damage your snow thrower and void your warranty.

# REPAIR PARTS

# SNOW THROWER - - MODEL NUMBER 944.528411

## AUGER HOUSING / IMPELLER ASSEMBLY

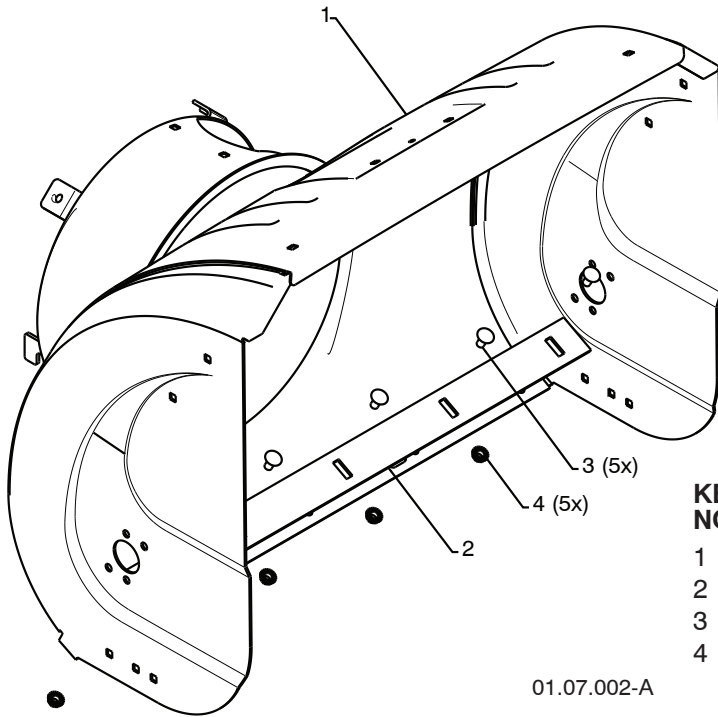

01.07.002-A

KEY NO.	PART NO.	DESCRIPTION
1	404929X615	AUGER HOUSING 27
2	404932X479	SCRAPER BAR
3	72270505	CARRIAGE BOLT 5/16-18 X .625
4	155377	NUT 5/16-18

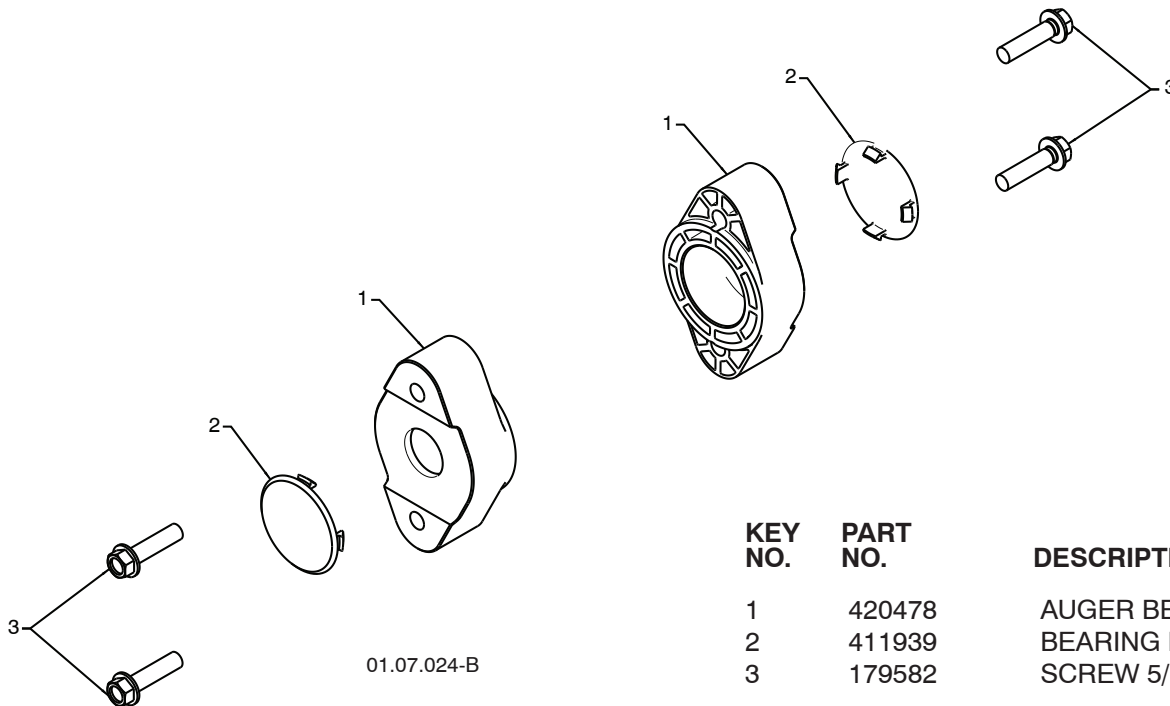

01.07.024-B

KEY NO.	PART NO.	DESCRIPTION
1	420478	AUGER BEARING
2	411939	BEARING PLUG
3	179582	SCREW 5/16-18 X 1.00

**NOTE:** All component dimensions given in U.S. inches. 1 inch = 25.4 mm  
**IMPORTANT:** Use only Original Equipment Manufacturer (O.E.M.) replacement parts.  
 Failure to do so could be hazardous, damage your snow thrower and void your warranty.



# REPAIR PARTS

# SNOW THROWER - - MODEL NUMBER 944.528411

## AUGER HOUSING / IMPELLER ASSEMBLY

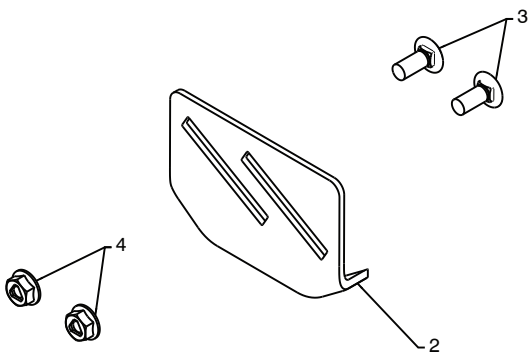
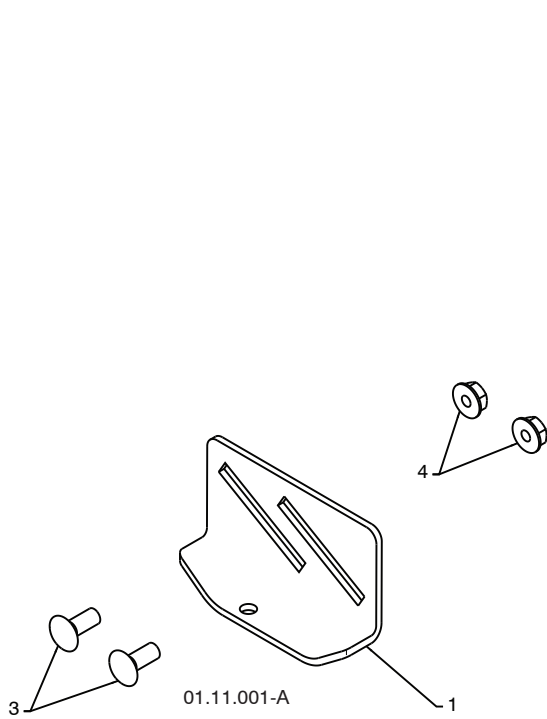

KEY NO.	PART NO.	DESCRIPTION
1	174762X479	SKID PLATE LH
2	178777X479	SKID PLATE RH
3	72270506	CARRIAGE BOLT 5/16-18 X .75
4	751153	NUT 5/16-18

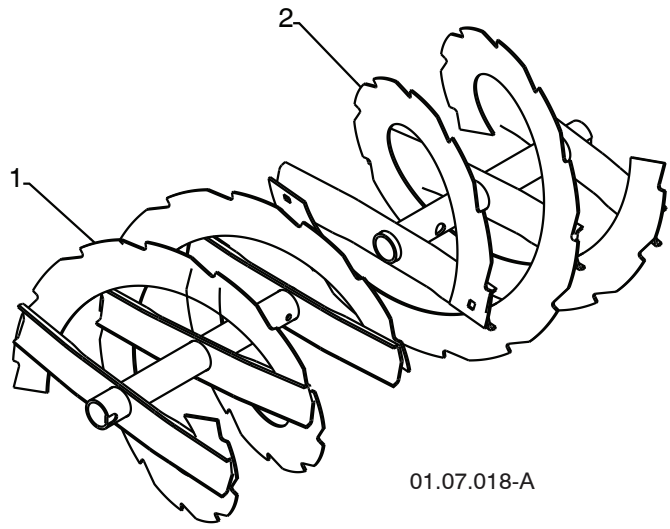

KEY NO.	PART NO.	DESCRIPTION
1	420495X479	AUGER 27 LH
2	420496X479	AUGER 27 RH

**NOTE:** All component dimensions given in U.S. inches. 1 inch = 25.4 mm  
**IMPORTANT:** Use only Original Equipment Manufacturer (O.E.M.) replacement parts. Failure to do so could be hazardous, damage your snow thrower and void your warranty.

# REPAIR PARTS

# SNOW THROWER - - MODEL NUMBER 944.528411

## AUGER HOUSING / IMPELLER ASSEMBLY

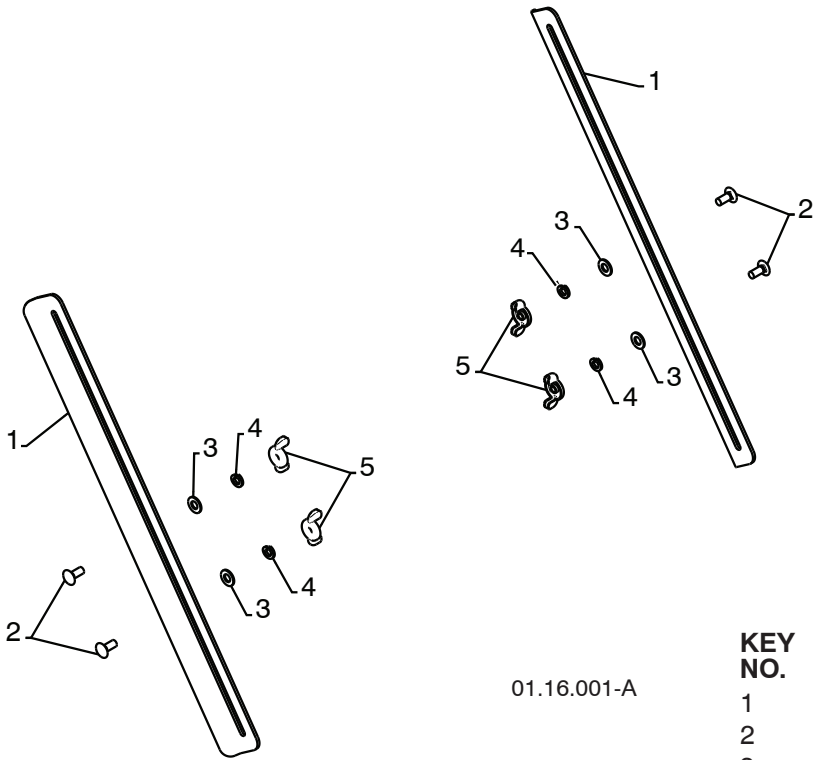

KEY NO.	PART NO.	DESCRIPTION
1	181160X479	DRIFT CUTTER BAR
2	72270506	CARRIAGE BOLT 5/16-18 X .750
3	179246	PLASTIC WASHER
4	10040500	LOCKWASHER 5/16
5	128638	NUT 5/16-18

**NOTE:** All component dimensions given in U.S. inches. 1 inch = 25.4 mm  
**IMPORTANT:** Use only Original Equipment Manufacturer (O.E.M.) replacement parts.  
Failure to do so could be hazardous, damage your snow thrower and void your warranty.

# REPAIR PARTS

# SNOW THROWER - - MODEL NUMBER 944.528411

## CONTROL PANEL / DISCHARGE CHUTE

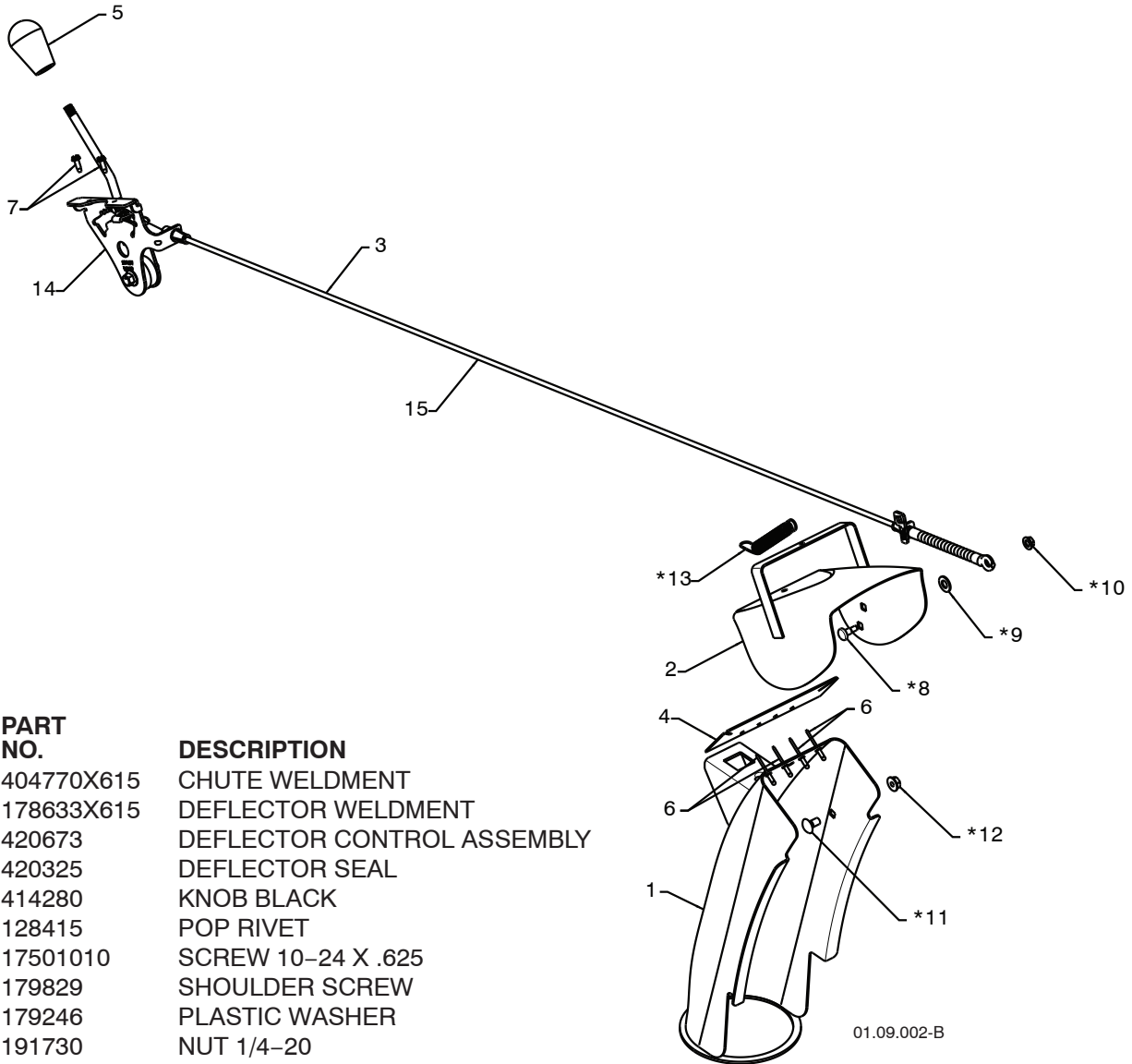

KEY NO.	PART NO.	DESCRIPTION
1	404770X615	CHUTE WELDMENT
2	178633X615	DEFLECTOR WELDMENT
3	420673	DEFLECTOR CONTROL ASSEMBLY
4	420325	DEFLECTOR SEAL
5	414280	KNOB BLACK
6	128415	POP RIVET
7	17501010	SCREW 10-24 X .625
*8	179829	SHOULDER SCREW
*9	179246	PLASTIC WASHER
*10	191730	NUT 1/4-20
*11	72250505	CARRIAGE BOLT 5/16-18 X .50
*12	751153	NUT 5/16-18
*13	184505	DEFLECTOR SPRING
14	420679	(SERVICE PART) DEFLECTOR CONTROL HEAD
15	420672	(SERVICE PART) DEFLECTOR CONTROL CABLE

### NOTE:

1. ALL ITEMS INDICATED WITH AN \* ARE PROVIDED IN THE BAG OF ITEMS SHIPPED LOOSE WITH PRODUCT.
2. ITEMS 14 AND 15 ARE SERVICE PART NUMBERS TO ALLOW PURCHASE OF INDIVIDUAL ITEMS IF NECESSARY.

**NOTE:** All component dimensions given in U.S. inches. 1 inch = 25.4 mm  
**IMPORTANT:** Use only Original Equipment Manufacturer (O.E.M.) replacement parts.  
 Failure to do so could be hazardous, damage your snow thrower and void your warranty.

# REPAIR PARTS

# SNOW THROWER - - MODEL NUMBER 944.528411

## CONTROL PANEL / DISCHARGE CHUTE

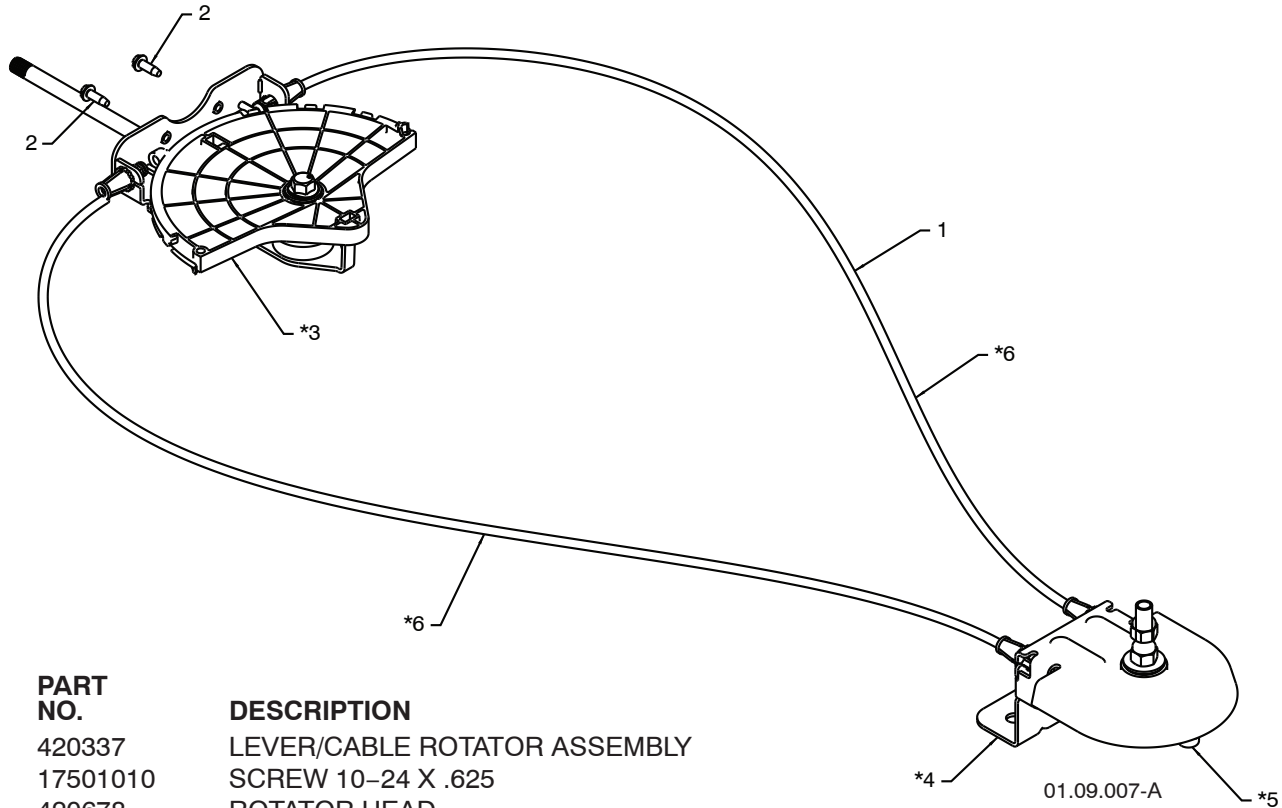

KEY NO.	PART NO.	DESCRIPTION
1	420337	LEVER/CABLE ROTATOR ASSEMBLY
2	17501010	SCREW 10-24 X .625
*3	420678	ROTATOR HEAD
*4	420677	ROTATOR PIVOT BRACKET
*5	420675	PULLEY PIVOT
*6	420674	CABLE ASSEMBLY

### NOTES:

1. ITEMS INDICATED WITH AN \* ARE LISTED AS REFERENCE FOR SERVICE PARTS ONLY.

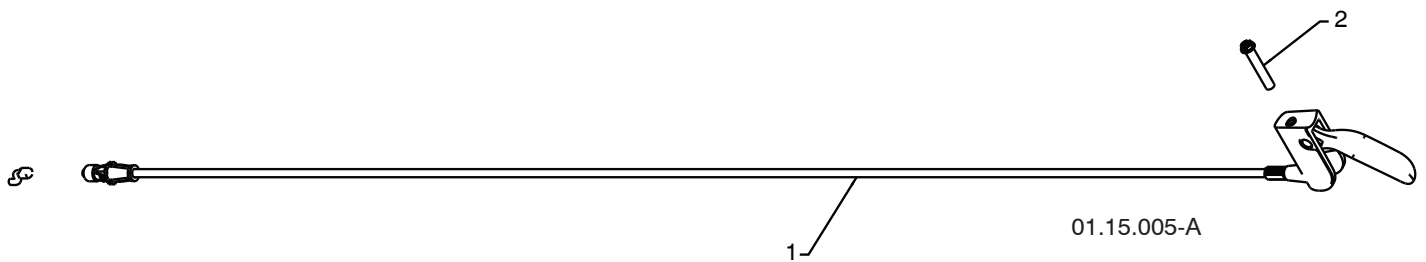

KEY NO.	PART NO.	DESCRIPTION
1	188303	STEER CABLE
2	74041024	SCREW 10-24 X 1.50

**NOTE:** All component dimensions given in U.S. inches. 1 inch = 25.4 mm  
**IMPORTANT:** Use only Original Equipment Manufacturer (O.E.M.) replacement parts.  
 Failure to do so could be hazardous, damage your snow thrower and void your warranty.

# REPAIR PARTS HANDLES

# SNOW THROWER - - MODEL NUMBER 944.528411

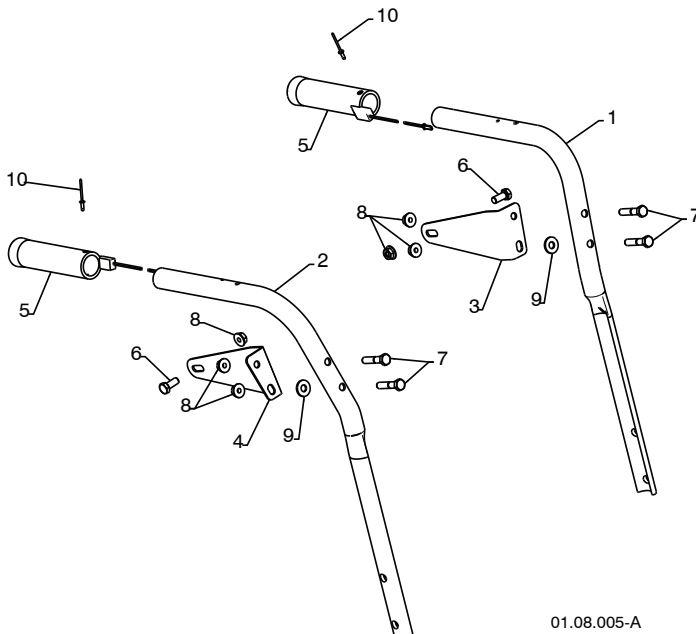

KEY NO.	PART NO.	DESCRIPTION
1	419800X479	PLOW HANDLE LH
2	419801X479	PLOW HANDLE RH
3	196944	PANEL BRACKET LH
4	196943	PANEL BRACKET RH
5	414515	HEATED HANDLE GRIP
6	74780512	CREW 5/16-18 X .750
7	74780524	SCREW 5/16-18 X 1.50
8	751153	NUT 5/16-18
9	155415	WASHER
10	178775	POP RIVET 1/8

01.08.005-A

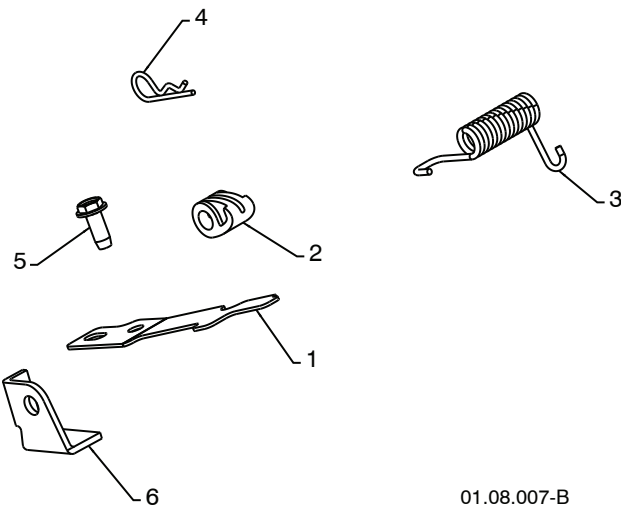

KEY NO.	PART NO.	DESCRIPTION
1	412675X004	INTERLOCK SPRING
2	414572	INTERLOCK CAM
3	178831	TORSION SPRING
4	169675	RETAINER
5	17060410	SCREW 1/4-20 X .625
6	421252	INTERLOCK STOP

01.08.007-B

**NOTE:** All component dimensions given in U.S. inches. 1 inch = 25.4 mm  
**IMPORTANT:** Use only Original Equipment Manufacturer (O.E.M.) replacement parts.  
 Failure to do so could be hazardous, damage your snow thrower and void your warranty.

# REPAIR PARTS HANDLES

# SNOW THROWER - - MODEL NUMBER 944.528411

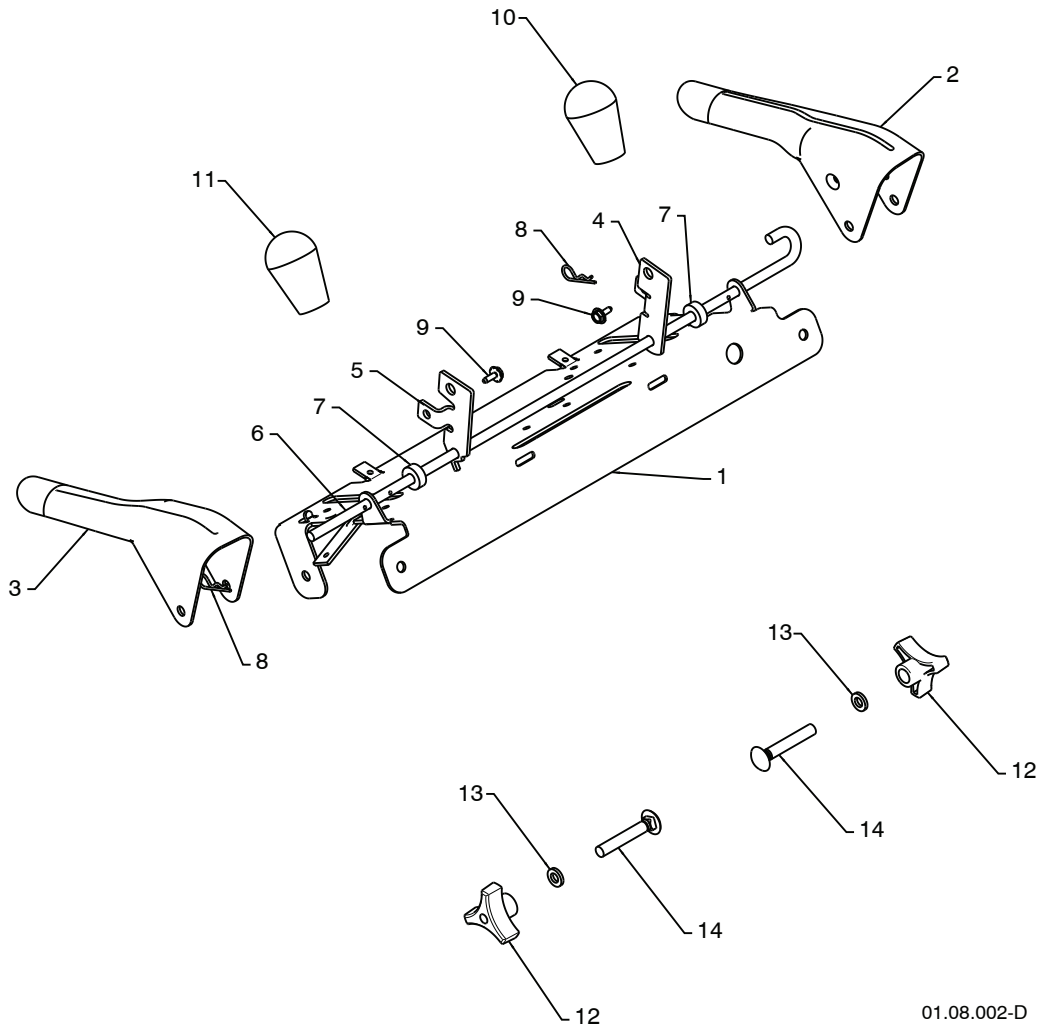

01.08.002-D

KEY NO.	PART NO.	DESCRIPTION
1	412683X479	CONTROL PANEL
2	412681X479	CONTROL LEVER LH
3	412682X479	CONTROL LEVER RH
4	412679X008	TRACTION ROD ARM
5	420889X008	IMPELLER ROD ARM
6	412677	INTERLOCK ROD
7	412680	SPACER
8	169675	RETAINER
9	17060408	SCREW 1/4-20 X .50
10	414280	KNOB BLACK
11	414281	KNOB RED
12	178899	HANDLE KNOB
13	19131316	WASHER 3/8
14	72120618	CARRIAGE BOLT 3/8-16 X 2.25

**NOTE:** All component dimensions given in U.S. inches. 1 inch = 25.4 mm  
**IMPORTANT:** Use only Original Equipment Manufacturer (O.E.M.) replacement parts.  
 Failure to do so could be hazardous, damage your snow thrower and void your warranty.

# REPAIR PARTS HANDLES

# SNOW THROWER - - MODEL NUMBER 944.528411

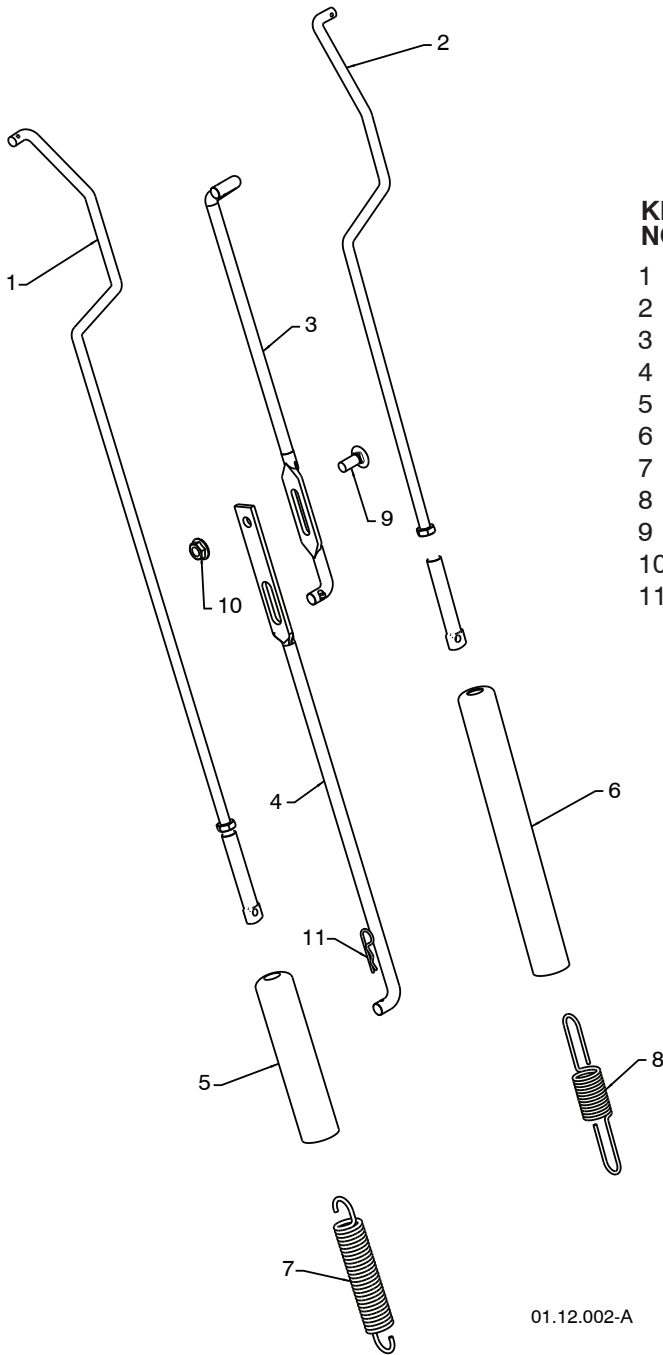

KEY NO.	PART NO.	DESCRIPTION
1	193447	IMPELLER ROD ASSEMBLY
2	180485	TRACTION ROD ASSEMBLY
3	187782	SHIFTER ROD TOP
4	187784	SHIFTER ROD BOTTOM
5	180447	SPRING SLEEVE
6	192091	SPRING SLEEVE
7	178669	IMPELLER SPRING
8	180926	TRACTION SPRING
9	72270506	CARRIAGE BOLT 5/16-18 X .750
10	155377	NUT 5/16-18
11	169675	RETAINER

01.12.002-A

**NOTE:** All component dimensions given in U.S. inches. 1 inch = 25.4 mm  
**IMPORTANT:** Use only Original Equipment Manufacturer (O.E.M.) replacement parts.  
 Failure to do so could be hazardous, damage your snow thrower and void your warranty.

# REPAIR PARTS HANDLES

# SNOW THROWER - - MODEL NUMBER 944.528411

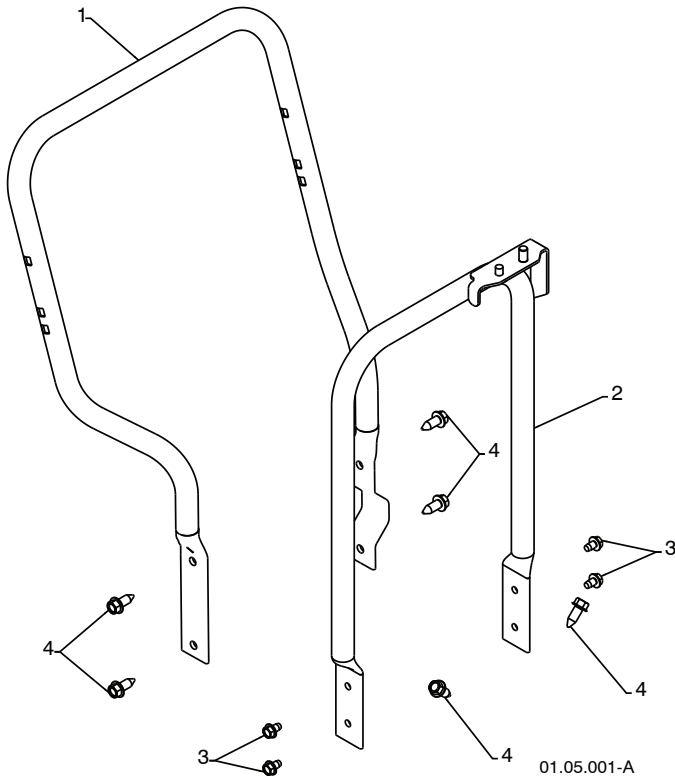

KEY NO.	PART NO.	DESCRIPTION
1	419796X479	LOWER TUBE
2	405784X479	PIVOT SUPPORT
3	17490508	BOLT 5/16-18 X .500
4	17000616	SCREW 3/8-16 X 1.00

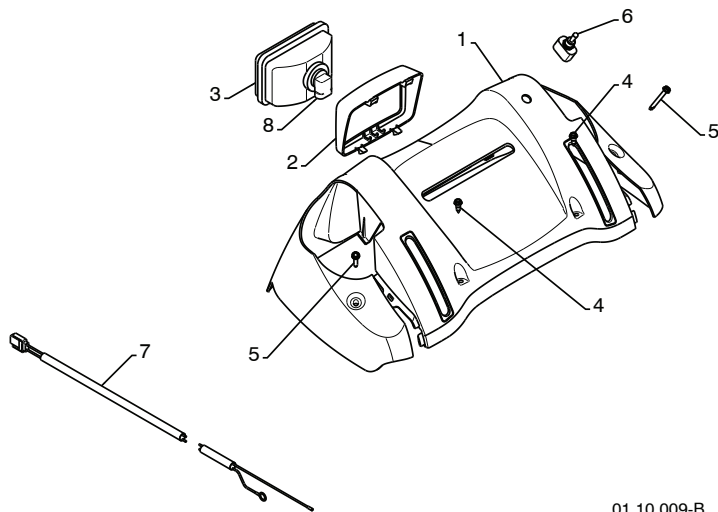

KEY NO.	PART NO.	DESCRIPTION
1	405879	CONSOLE PANEL
2	178668	HEADLIGHT BEZEL
3	178666	HALOGEN HEADLIGHT
4	184471	SHOULDER SCREW 10-24 X .625
5	175262	SCREW 10-24 X 1.25
6	405781	GRIP SWITCH
7	405699	WIRE HARNESS
8	401620	BULB

01.10.009-B

**NOTE:** All component dimensions given in U.S. inches. 1 inch = 25.4 mm  
**IMPORTANT:** Use only Original Equipment Manufacturer (O.E.M.) replacement parts.  
 Failure to do so could be hazardous, damage your snow thrower and void your warranty.



**REPAIR PARTS**  
**DRIVE**

**SNOW THROWER - - MODEL NUMBER 944.528411**

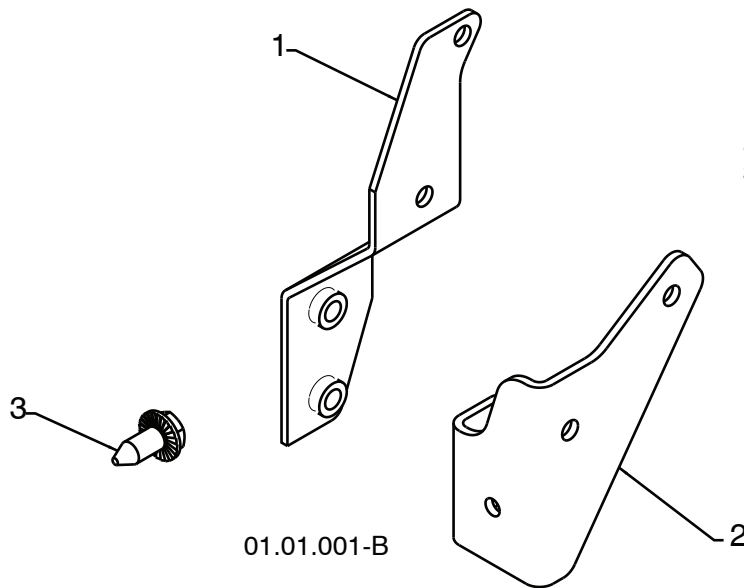

KEY NO.	PART NO.	DESCRIPTION
1	414771	TORQUE STRAP
2	193255X479	ANTI ROTATE BRACKET
3	150078	SCREW 5/16-18 X .750

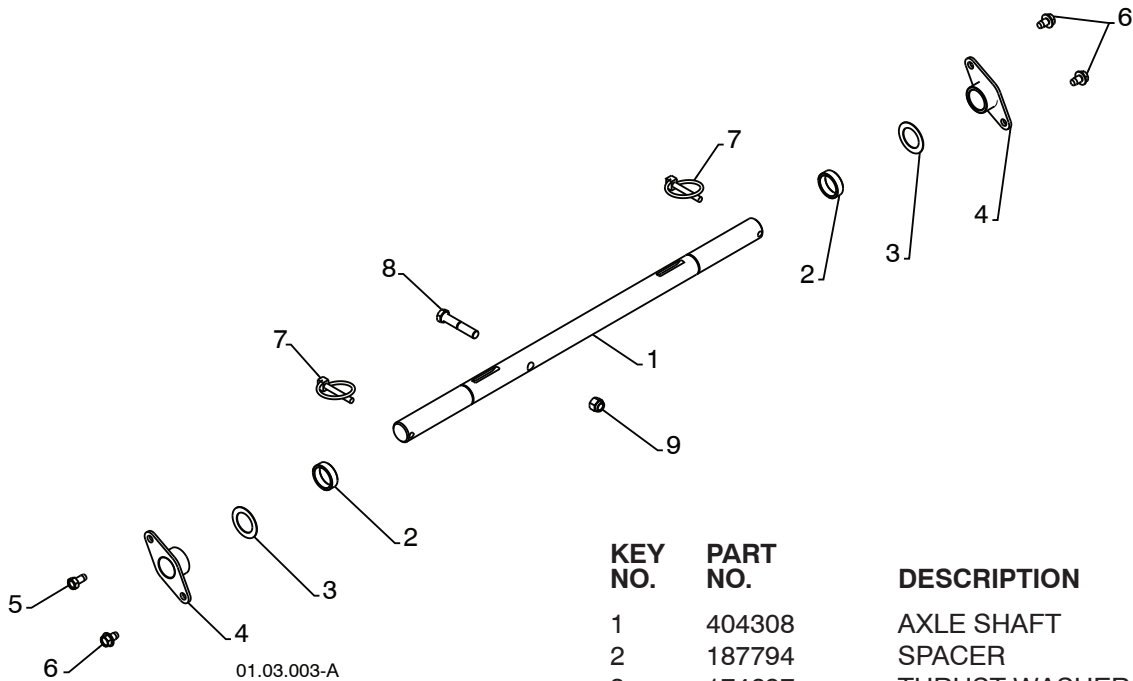

KEY NO.	PART NO.	DESCRIPTION
1	404308	AXLE SHAFT
2	187794	SPACER
3	174697	THRUST WASHER
4	179830	BEARING
5	146315	SCREW 5/16-18 X .625
6	17490508	BOLT 5/16-18 X .500
7	155443	CLIK PIN
8	74780632	SCREW 3/8-16 X 2.00
9	73800600	NUT 3/8-16

**NOTE:** All component dimensions given in U.S. inches. 1 inch = 25.4 mm  
**IMPORTANT:** Use only Original Equipment Manufacturer (O.E.M.) replacement parts.  
 Failure to do so could be hazardous, damage your snow thrower and void your warranty.

# REPAIR PARTS DRIVE

# SNOW THROWER - - MODEL NUMBER 944.528411

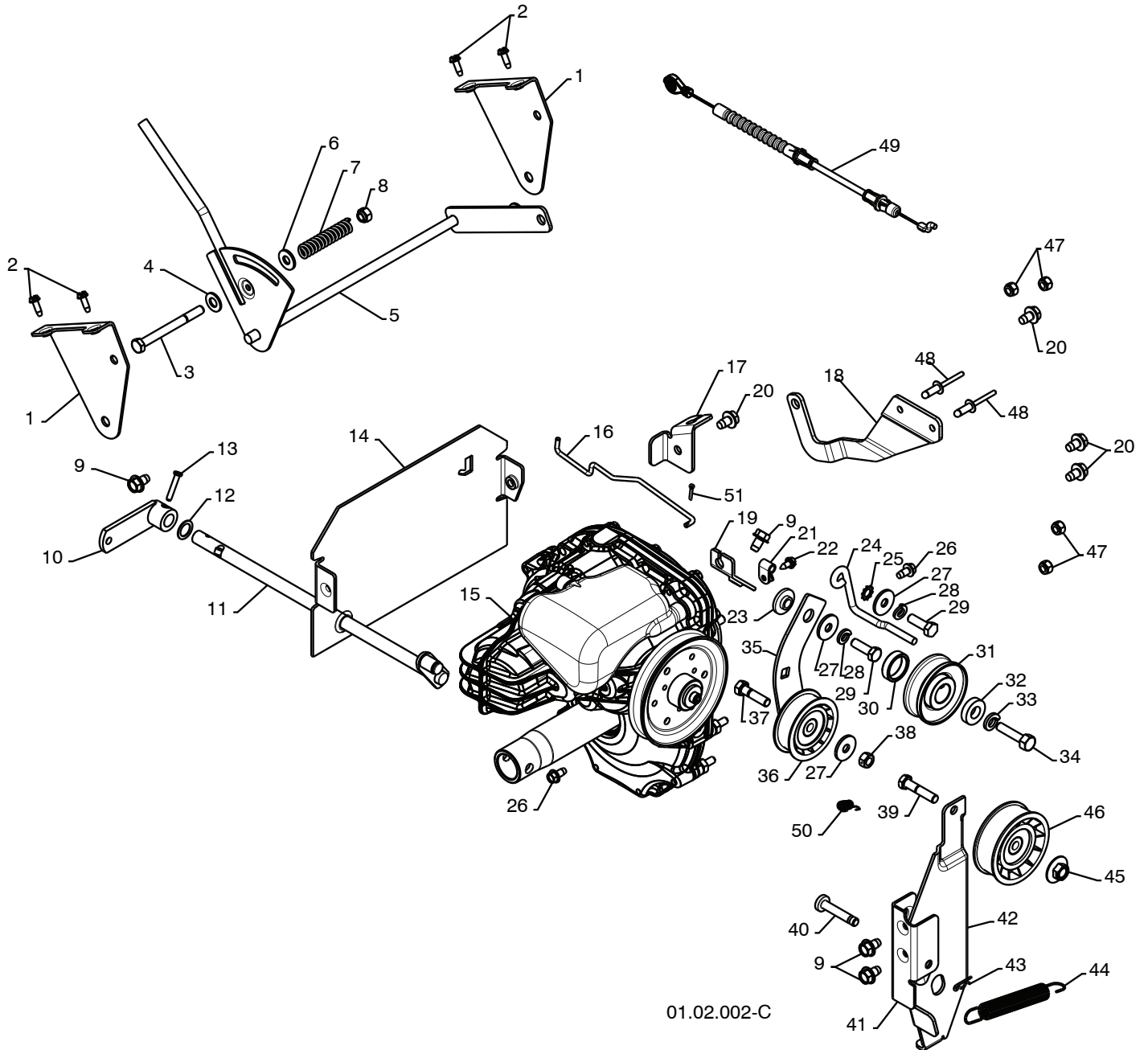

01.02.002-C

**NOTE:** All component dimensions given in U.S. inches. 1 inch = 25.4 mm  
**IMPORTANT:** Use only Original Equipment Manufacturer (O.E.M.) replacement parts.  
Failure to do so could be hazardous, damage your snow thrower and void your warranty.

# REPAIR PARTS DRIVE

# SNOW THROWER - - MODEL NUMBER 944.528411

KEY NO.	PART NO.	DESCRIPTION	KEY NO.	PART NO.	DESCRIPTION
1	192002	SHIFT BRACKET	27	59289	WASHER
2	17501010	SCREW 10-24 X .625	28	10040500	LOCKWASHER 5/16
3	74760522	SCREW 5/16-18 X 3.25	29	74610516	SCREW 5/16-18 X 1.00
4	179246	WASHER	30	409475	SPACER
5	192001	SHIFT ASSEMBLY	31	180478	ENGINE TRACTION PULLEY
6	155415	WASHER	32	400026	WASHER
7	192195	FRICTION SPRING	33	850263	LOCKWASHER 3/8
8	73800500	NUT 5/16-18	34	851084	SCREW 3/8-24 X 1.38
9	17490508	BOLT 5/16-18 X .500	35	187786	TRACTION IDLER ARM
10	405484	CONTROL ARM	36	180522	IDLER PULLEY
11	406109	CONTROL SHAFT	37	74780520	SCREW 5/16-18 X 1.25
12	57079	WASHER	38	73930500	NUT 5/16-18
13	198580	CLEVIS PIN	39	74780524	SCREW 5/16-18 X 1.50
14	192115X479	REAR PLATE	40	175330	PIN
15	187776	TRANSMISSION	41	193397X479	IDLER PIVOT BRACKET
16	193256	ROD	42	419925	IDLER BRAKE ARM
17	192000	REAR CABLE BRACKET	43	85179	RETAINER
18	187787	CONTROL ARM	44	178828	BRAKE SPRING
19	191993	FRONT CABLE BRACKET	45	166785	NUT 5/16-18
20	150078	SCREW 5/16-18 X .750	46	180523	PULLEY
21	87930	CLIP	47	73800400	NUT 1/4-20
22	17391208	SCREW .12 X .50	48	191995	POP RIVET 1/4 X .475
23	175331	BUSHING	49	198466	CLUTCH CABLE
24	193607	BELT GUIDE	50	192873	TRACTION SPRING
25	11050500	LOCKWASHER 5/16	51	700279	RETAINER CLIP
26	17490408	SCREW 1/4-20 X .500			

**NOTE:** All component dimensions given in U.S. inches. 1 inch = 25.4 mm  
**IMPORTANT:** Use only Original Equipment Manufacturer (O.E.M.) replacement parts.  
 Failure to do so could be hazardous, damage your snow thrower and void your warranty.

# REPAIR PARTS

# SNOW THROWER - - MODEL NUMBER 944.528411

## CHASSIS / ENGINE / PULLEYS

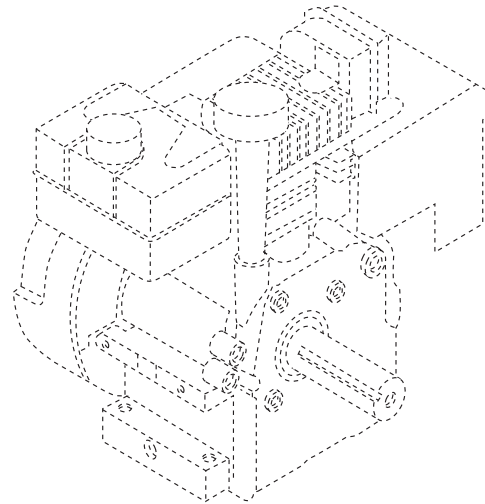
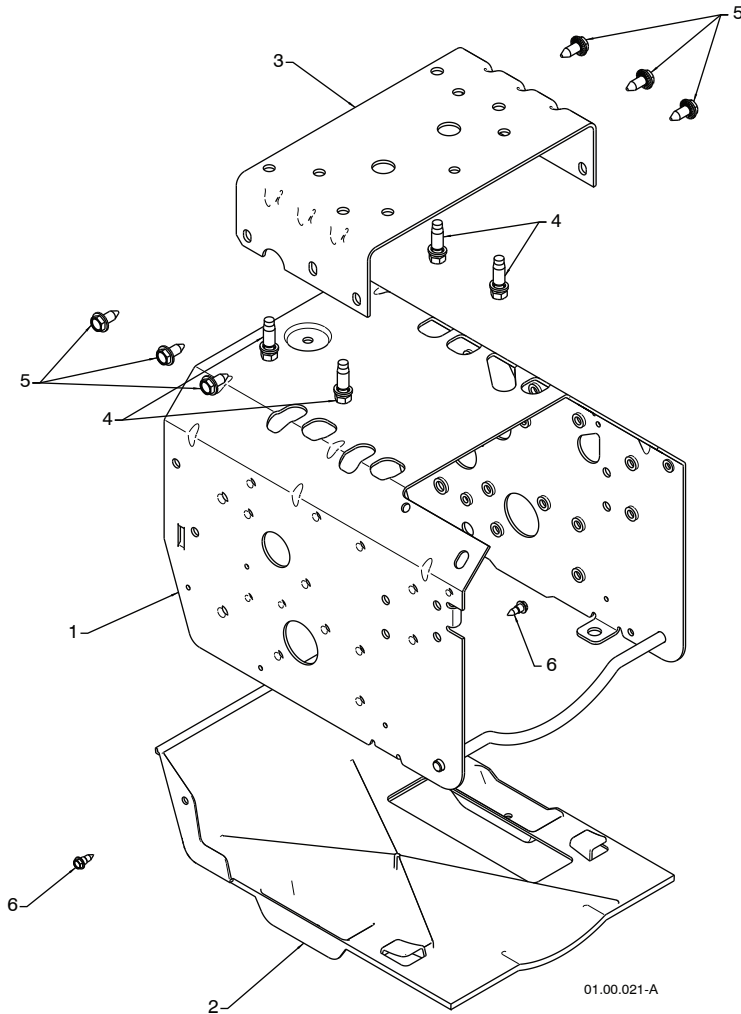

KEY NO.	PART NO.	DESCRIPTION
--	-----	B&S ENGINE MODEL 20P214-1183-E1
1	415004X615	FRAME
2	403732	BOTTOM PAN
3	417015X615	ENGINE MOUNT PLATE
4	150406	BOLT 3/8-16
5	150078	SCREW 5/16-18 X .750
6	184471	SCREW 10-24 X .625

**NOTE:** All component dimensions given in U.S. inches. 1 inch = 25.4 mm  
**IMPORTANT:** Use only Original Equipment Manufacturer (O.E.M.) replacement parts.  
 Failure to do so could be hazardous, damage your snow thrower and void your warranty.

# REPAIR PARTS

# SNOW THROWER - - MODEL NUMBER 944.528411

## CHASSIS / ENGINE / PULLEYS

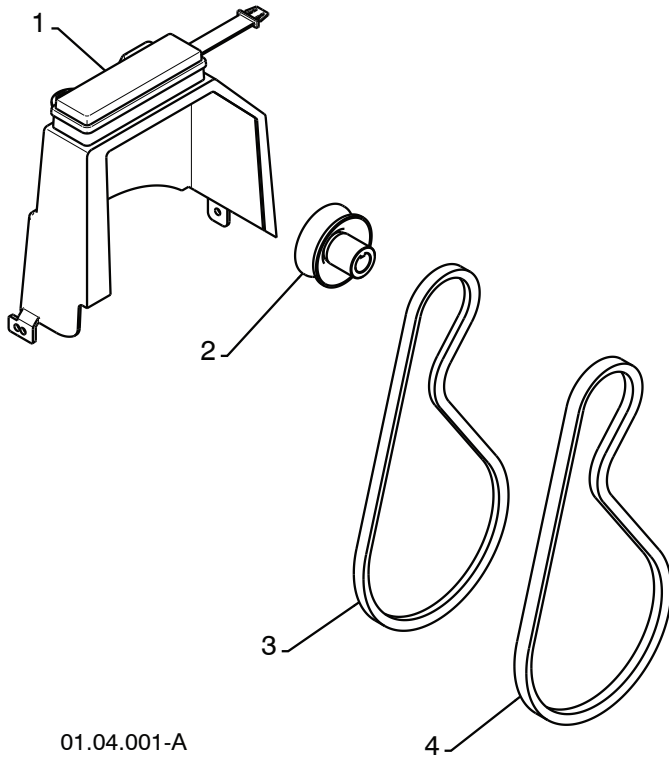

01.04.001-A

KEY NO.	PART NO.	DESCRIPTION
1	192213	COVER ASSEMBLY
2	179157	PULLEY
3	192383	TRACTION BELT
4	408007	IMPELLER BELT

**NOTE:** All component dimensions given in U.S. inches. 1 inch = 25.4 mm  
**IMPORTANT:** Use only Original Equipment Manufacturer (O.E.M.) replacement parts.  
Failure to do so could be hazardous, damage your snow thrower and void your warranty.

# REPAIR PARTS WHEELS

# SNOW THROWER - - MODEL NUMBER 944.528411

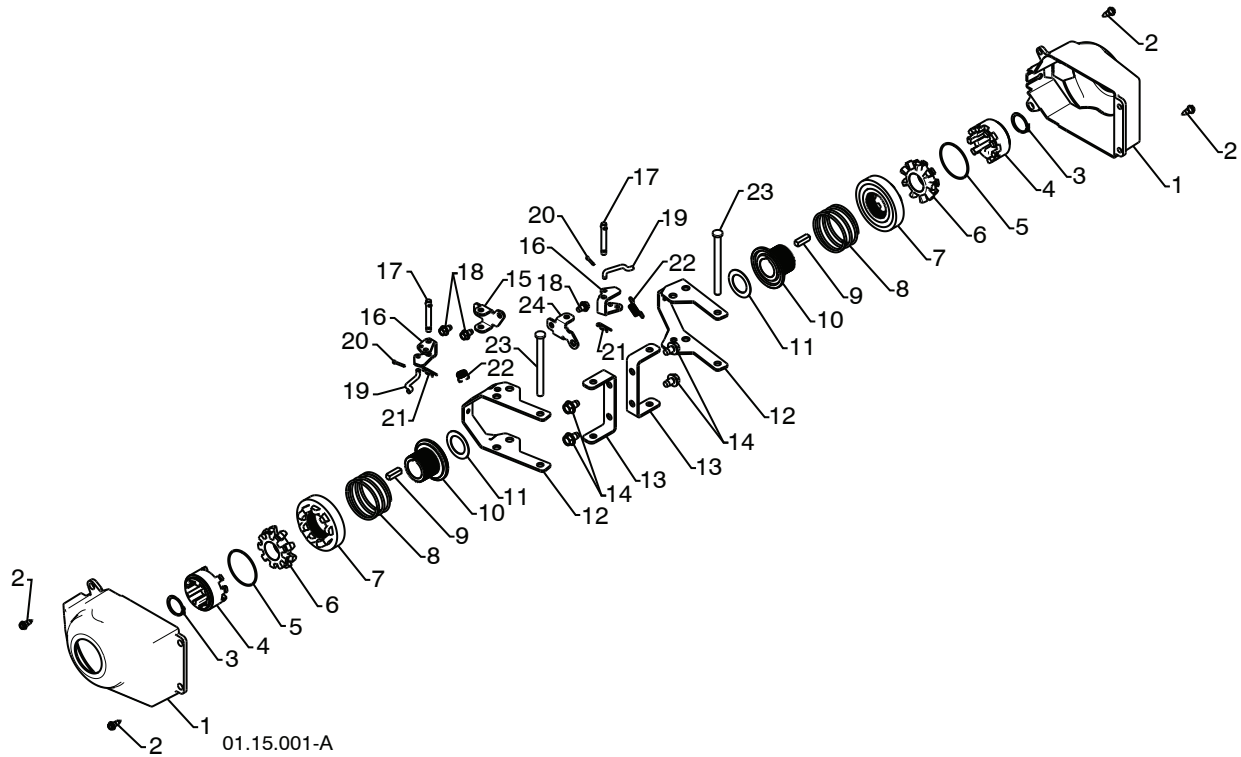

KEY NO.	PART NO.	DESCRIPTION
1	405161	COVER
2	184471	SHOULDER SCREW
3	12000045	RETAINER RING
4	192126	WHEEL DRIVER
5	182466	RETAINER RING
6	187622	WHEEL LOBE
7	194941	CLUTCH SLIDE
8	179139	SPRING
9	189282	SQUARE KEY
10	194940	AXLE LOBE
11	174697	THRUST WASHER
12	193506X479	STEERING YOKE
13	179148X479	STEERING BRACKET
14	17490508	SCREW 5/16-18 X .50
15	194943X008	PIVOT BRACKET
16	194944X008	BELLCRANK
17	181847	BELLCRANK PIN
18	17600406	SCREW 1/4-20 X .375
19	405077	STEERING LINK
20	700279	RETAINER
21	85179	RETAINER
22	193885	SPRING
23	182015	LEVER PIN
24	194939X008	PIVOT BRACKET

**NOTE:** All component dimensions given in U.S. inches. 1 inch = 25.4 mm  
**IMPORTANT:** Use only Original Equipment Manufacturer (O.E.M.) replacement parts.  
 Failure to do so could be hazardous, damage your snow thrower and void your warranty.

# REPAIR PARTS WHEELS

# SNOW THROWER - - MODEL NUMBER 944.528411

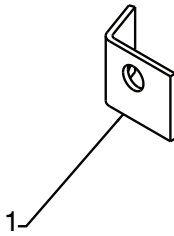
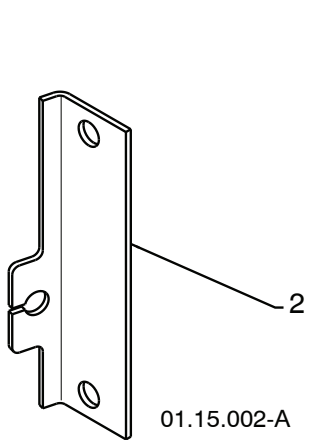

KEY NO.	PART NO.	DESCRIPTION
1	185602X004	STEER CABLE BRACKET LH
2	185603X479	STEER CABLE BRACKET RH

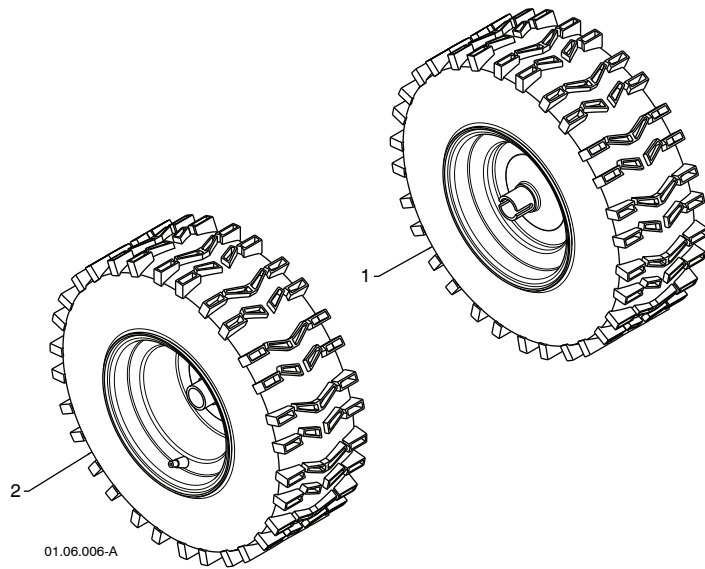

KEY NO.	PART NO.	DESCRIPTION
1	196752X417	WHEEL ASSEMBLY LH
2	196753X417	WHEEL ASSEMBLY RH

**NOTE:** All component dimensions given in U.S. inches. 1 inch = 25.4 mm  
**IMPORTANT:** Use only Original Equipment Manufacturer (O.E.M.) replacement parts.  
 Failure to do so could be hazardous, damage your snow thrower and void your warranty.

**REPAIR PARTS**  
**BAG OF PARTS**

**SNOW THROWER - - MODEL NUMBER 944.528411**

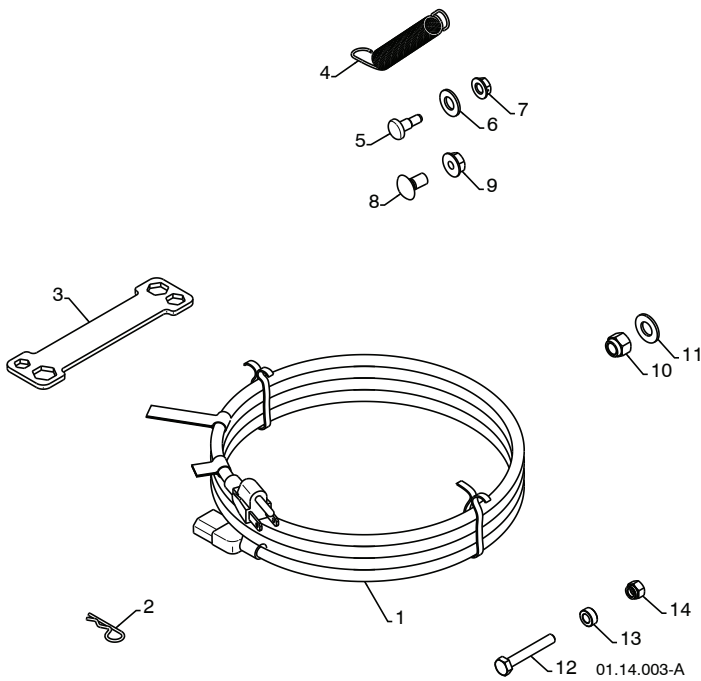

KEY NO.	PART NO.	DESCRIPTION
1	198563	POWER CORD
2	169675	RETAINER PIN
3	180684	WRENCH
4	184505	REMOTE SPRING
5	179829	SHOULDER BOLT 1/4-20
6	179246	NYLON WASHER 1/4-20
7	191730	LOCKNUT 1/4-20
8	72250505	CARRIAGE BOLT 5/16-18 X 5/8
9	751153	LOCKNUT 5/16-18
10	73800600	LOCKNUT 3/8-16
11	19131316	WASHER 3/8
12	198636	SHEAR BOLT 1/4-20 X 1-3/4
13	198638	SPACER
14	73800400	LOCKNUT 1/4-20



01.14.007-A

KEY NO.	PART NO.	DESCRIPTION
1	193071	SAFETY IGNITION KEY

**NOTE:** All component dimensions given in U.S. inches. 1 inch = 25.4 mm  
**IMPORTANT:** Use only Original Equipment Manufacturer (O.E.M.) replacement parts.  
 Failure to do so could be hazardous, damage your snow thrower and void your warranty.



# REPAIR PARTS DECALS

# SNOW THROWER - - MODEL NUMBER 944.528411

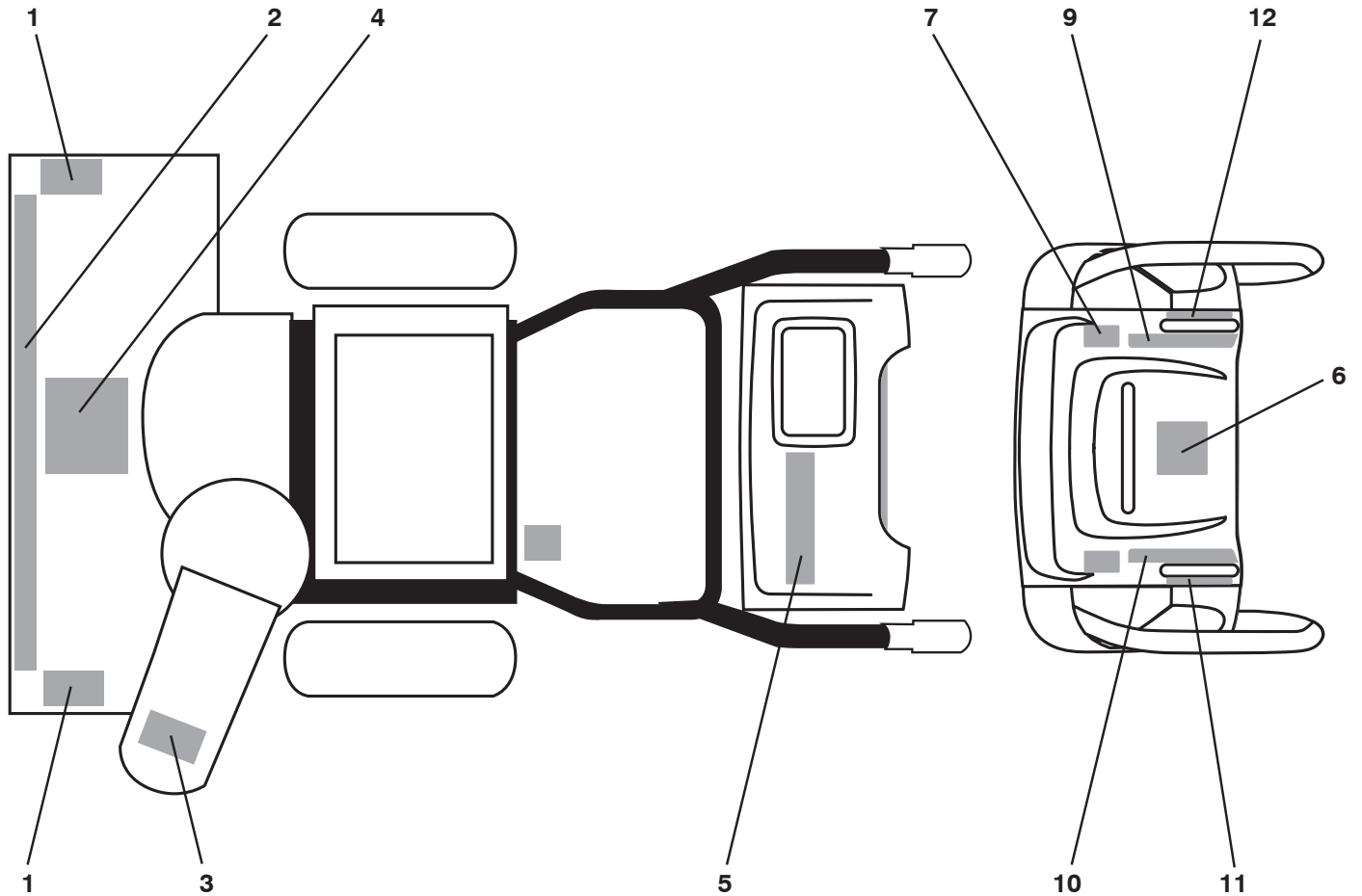

KEY NO.	PART NO.	DESCRIPTION
1	181037	DECAL, DANGER
2	421388	DECAL, CRAFTSMAN
3	181035	DECAL, DANGER, DEFLECTOR
4	181042	DECAL, DANGER
5	421387	DECAL, CRAFTSMAN
6	181033	DECAL, INSTRUCTION
7	415455	DECAL, AUTOMATIC
9	415475	DECAL, SPEED CONTROL
10	183730	DECAL, REMOTE DEFLECTOR
11	415399	DECAL, LH TRIGGER
12	415398	DECAL, RH TRIGGER
--	421301	OWNER'S MANUAL, ENGLISH
--	421302	OWNER'S MANUAL, FRENCH

**NOTE:** All component dimensions given in U.S. inches. 1 inch = 25.4 mm  
**IMPORTANT:** Use only Original Equipment Manufacturer (O.E.M.) replacement parts.  
 Failure to do so could be hazardous, damage your snow thrower and void your warranty.

1058 OPERATOR'S MANUAL

1329 REPLACEMENT ENGINE

48 SHORT BLOCK

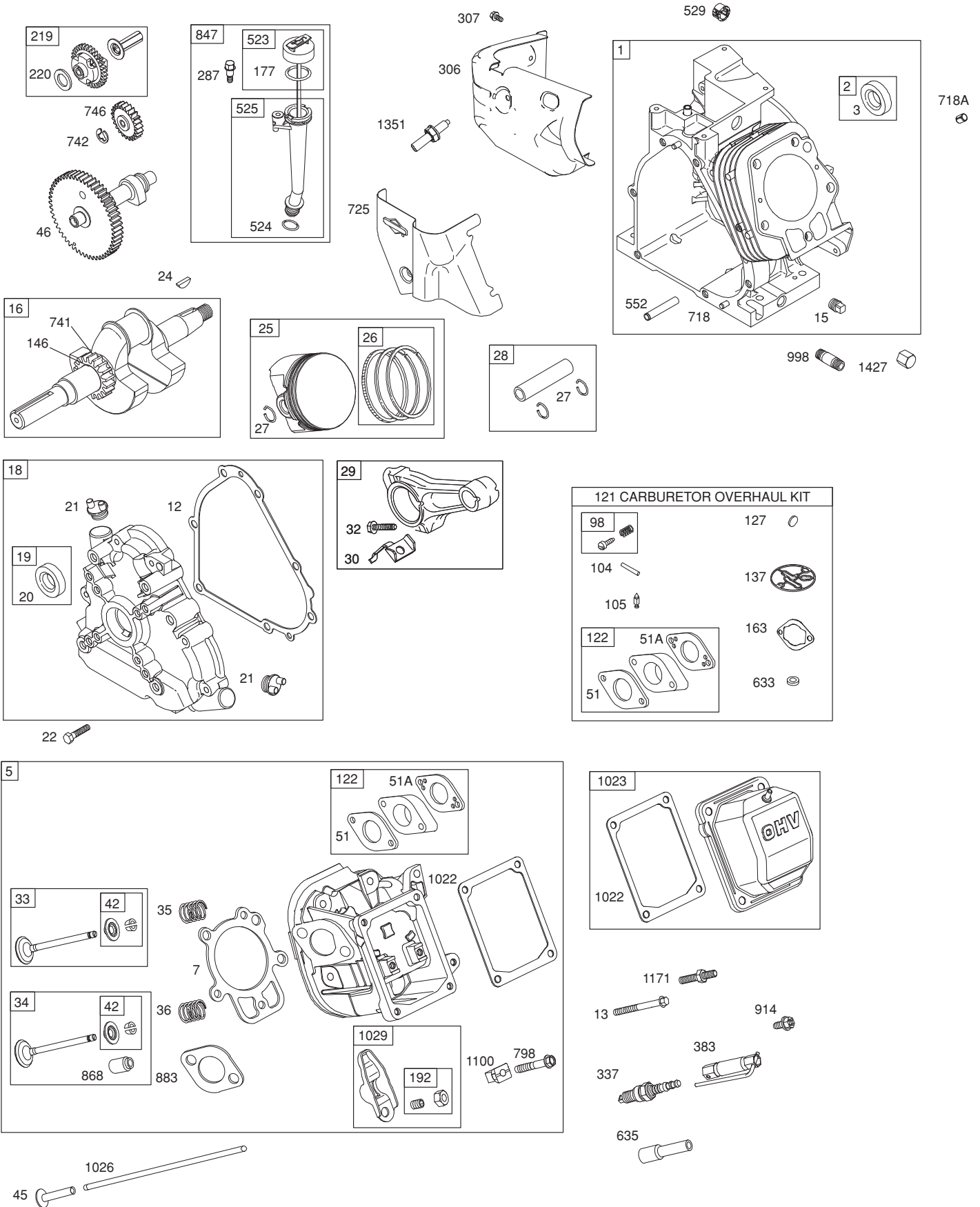

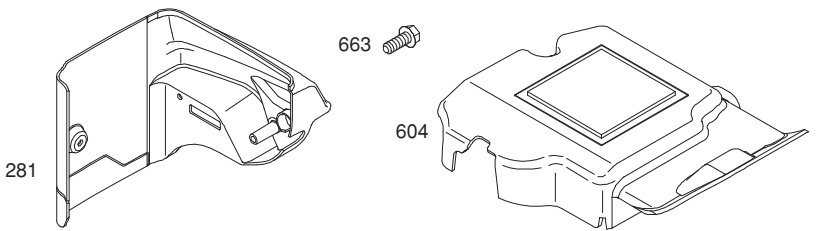
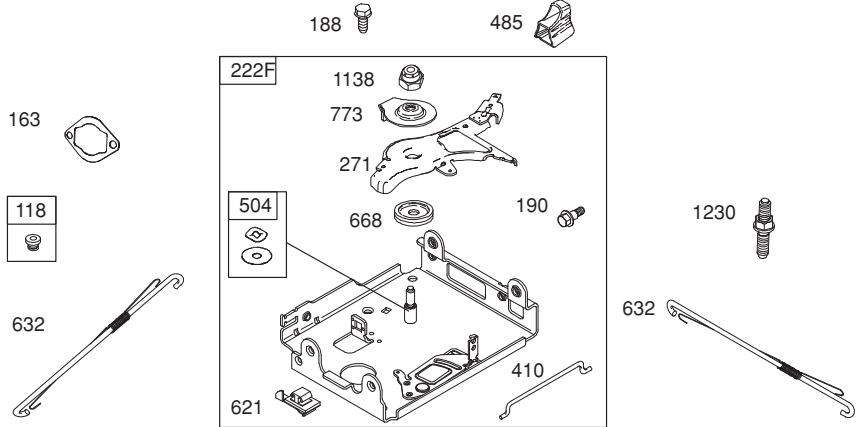
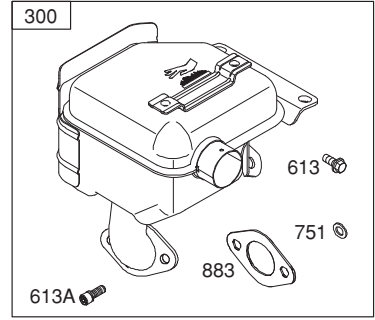
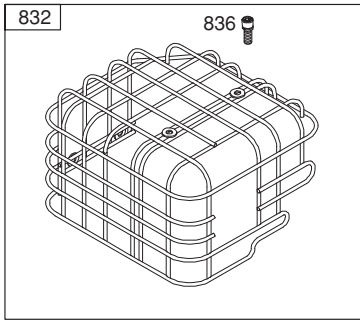
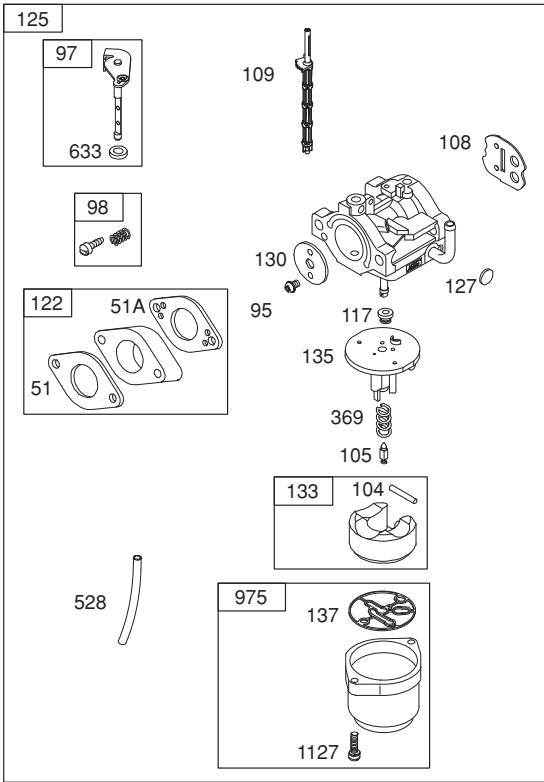
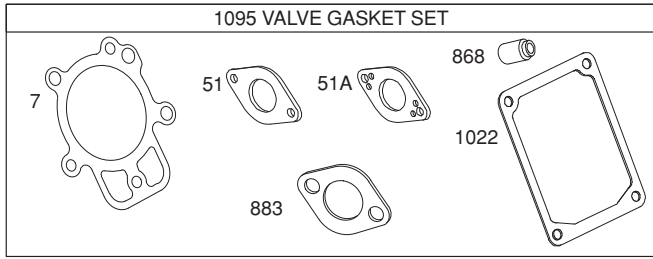
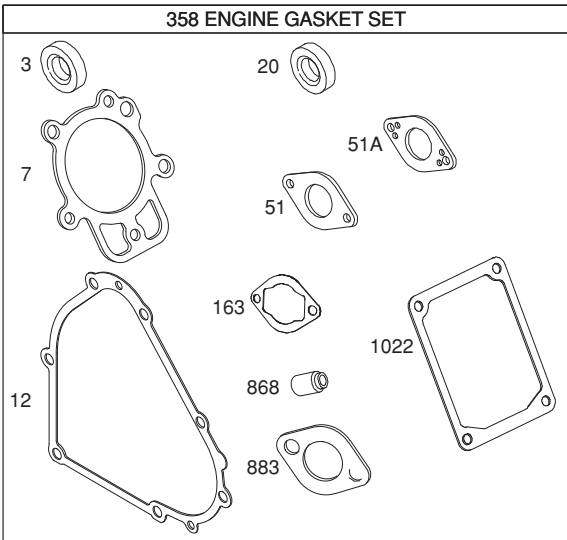

1036 EMISSIONS LABEL

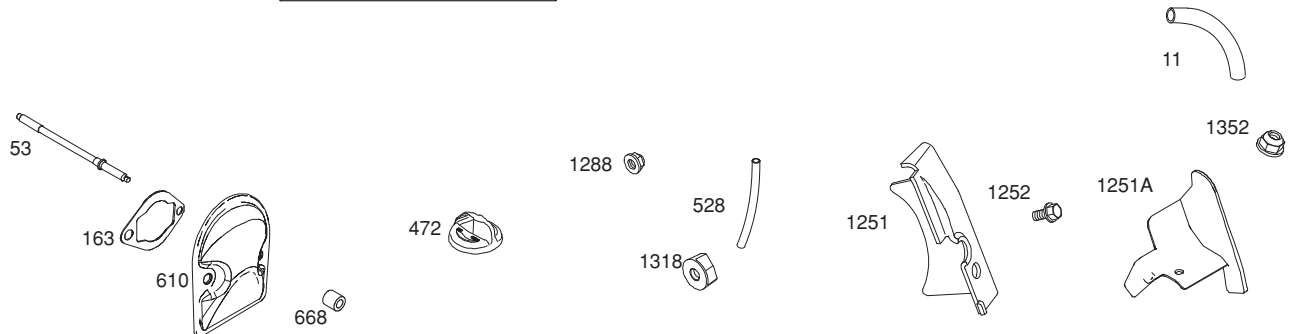

1196 1196A

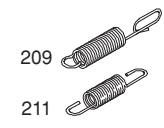
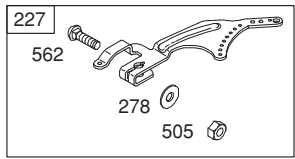
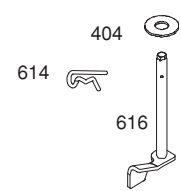
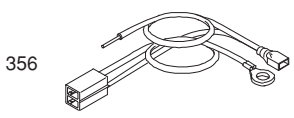
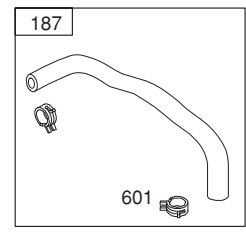
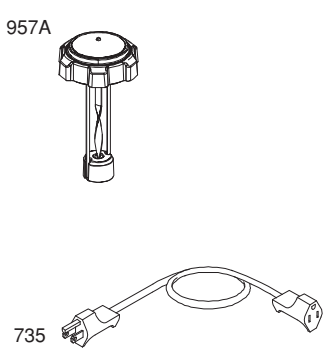
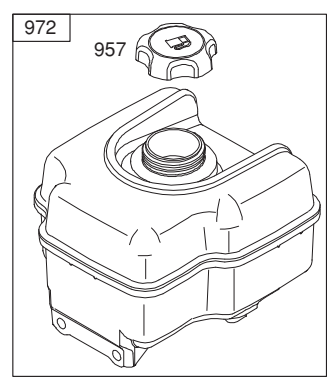
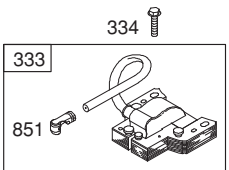
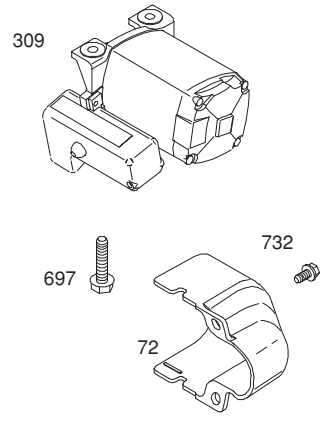
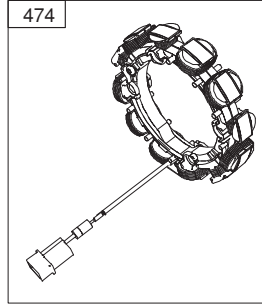
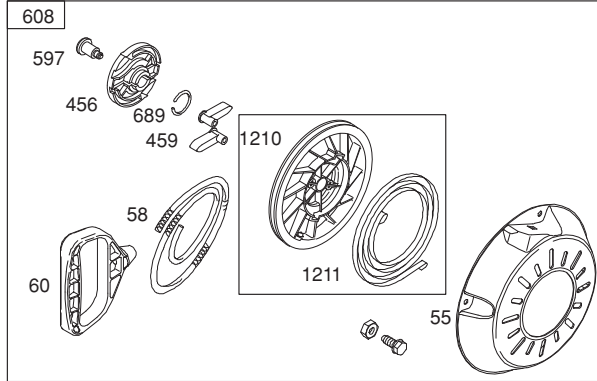
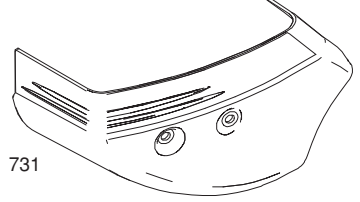
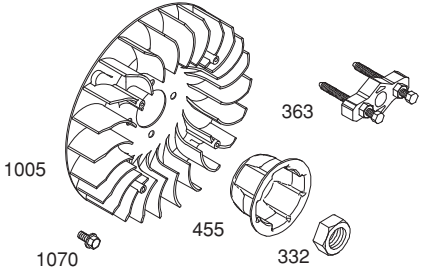
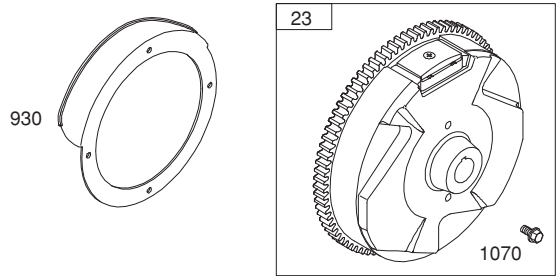
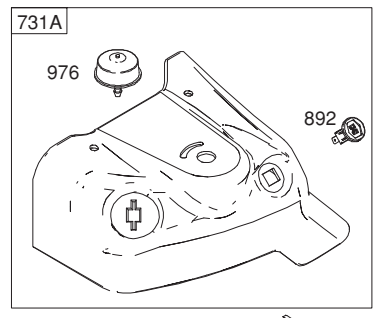
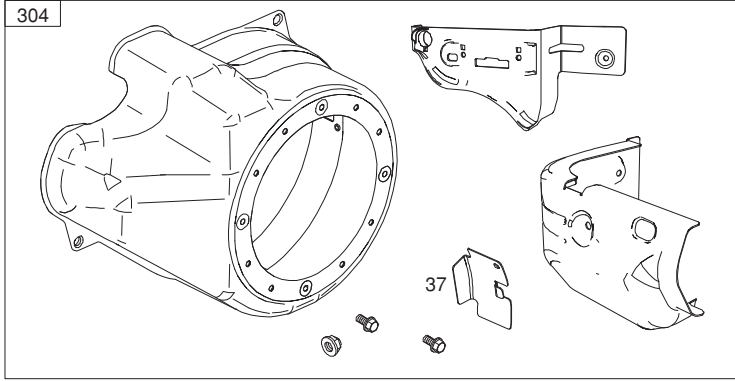

KEY NO.	PART NO.	DESCRIPTION	KEY NO.	PART NO.	DESCRIPTION
1	794849	Cylinder Assembly	127	690727 Ø	Plug-Welch
2	698340	Kit-Bushing/Seal (Magneto Side)	130	696139	Valve-Throttle
3	391086s •	Seal-Oil (Magneto Side)	133	694914	Float-Carburetor
5	794871	Head-Cylinder	135	696142	Tube-Fuel Transfer
7	694872 •+	Gasket-Cylinder Head	137	695426 Ø	Gasket-Float Bowl
11	696750	Tube-Breather	146	690979	Key-Timing
12	694953 •	Gasket-Crankcase	163	692277 +Ø	Gasket-Air Cleaner
13	794829	Screw (Cylinder Head)	177	691031	Seal-O Ring (Dipstick)
15	691686	Plug-Oil Drain	187	791879	Line-Fuel (Formed)
16	794720	Crankshaft	188	699479	Screw (Control Bracket)
18	791965	Cover-Crankcase	190	699220	Screw (Fuel Tank)
19	698340	Kit-Bushing/Seal (PTO Side)	192	690083	Adjuster-Rocker Arm
20	391086s •	Seal-Oil (PTO Side)	209	694867	Spring-Governor
21	281658s	Cap-Oil Fill	211	695307	Spring-Governed Idle
22	794825	Screw (Crankcase Cover/Sump)	219	693578	Gear-Governor
23	794812	Flywheel	220	691724	Washer (Governor Gear)
24	222698s	Key-Flywheel	222	794800	Bracket-Control
25	792023	Piston Assembly (Standard)	227	694864	Lever-Governor Control
	792144	Piston Assembly (.020" Oversize)	271	698035	Lever-Control
26	793561	Ring Set (Standard)	278	792008	Washer (Governor Control Lever)
	792073	Ring Set (.020" Oversize)	287	699629	Screw (Dipstick Tube)
27	690975	Lock-Piston Pin	300	794948	Muffler
28	696581	Pin-Piston	304	795699	Housing-Blower
29	694691	Rod-Connecting	305	699480	Screw (Blower Housing)
30	694692	Dipper-Connecting Rod	306	697240	Shield-Cylinder
32	690976	Screw (Connecting Rod)	307	794822	Screw (Cylinder Shield)
33	499596	Valve-Exhaust	309	793524	Motor-Starter
34	795199	Valve-Intake	332	794824	Nut (Flywheel)
35	694865	Spring-Valve (Intake)	333	492341	Armature-Magneto
36	694865	Spring-Valve (Exhaust)	334	699477	Screw (Magneto Armature)
37	699047	Guard-Flywheel	337	691043	Plug-Spark
42	499586	Keeper-Valve	356	793206	Wire-Stop
45	690977	Tappet-Valve	358	795201	Gasket Set-Engine
46	795697	Camshaft	363	19203	Puller-Flywheel
48	794910	Short Block	369	695422	Spring-Float Bowl
51	694874 •+ Ø	Gasket-Intake	383	19374s	Wrench-Spark Plug
51A	694875 •+ Ø	Gasket-Intake	404	795759	Washer (Governor Crank)
53	795017	Stud (Carburetor)	410	695382	Link-Control
55	696710	Housing-Rewind Starter	455	795011	Cup-Flywheel
58	693389	Rope-Starter (Cut to Required Length)	456	692299	Plate-Pawl Friction
			459	281505s	Pawl-Ratchet
60	699334	Grip-Starter Rope	472	791948	Knob-Choke Shaft
65	699851	Screw (Rewind Starter)	474	793118	Alternator
78	699205	Screw (Flywheel Guard)	485	695755	Knob-Control
95	690718	Screw (Throttle Valve)	504	694254	Washer Set-Friction
97	696387	Shaft-Throttle	505	691251	Nut (Governor Control Lever)
98	695408 Ø	Kit-Idle Speed	523	695344	Dipstick
104	694918 Ø	Pin-Float Hinge	524	691876	Seal-O Ring (Dipstick Tube)
105	696136 Ø	Valve-Float Needle	525	695343	Tube-Dipstick
108	696736	Valve-Choke	528	793006	Hose-Primer
109	793162	Shaft-Choke	529	791822	Grommet
117	696134 Ø	Jet-Main (Standard)	552	694674	Bushing-Governor Crank
118	696135 Ø	Jet-Main (High Altitude)	562	793216	Bolt (Governor Control Lever)
121	696146	Kit-Carburetor Overhaul	597	691696	Screw (Pawl Friction Plate)
122	694876 Ø	Spacer-Carburetor	601	791850	Clamp-Hose
125	794593	Carburetor	604	696758	Cover-Control

KEY NO.	PART NO.	DESCRIPTION	KEY NO.	PART NO.	DESCRIPTION
608	699335	Starter-Rewind	975	696138	Bowl-Float
610	794541	Arrester-Intake	976	793382	Primer-Carburetor
613	794846	Screw (Muffler)	998	792928	Pipe-Oil
613A	794844	Screw (Muffler)	1005	794815	Fan-Flywheel
614	691620	Pin-Cotter	1022	690971 •+	Gasket-Rocker Cover
616	795758	Crank-Governor	1023	698042	Cover-Rocker
621	692310	Switch-Stop	1026	695177	Rod-Push
632	695917	Spring/Link-Mechanical Governor	1029	690972	Arm-Rocker
633	690998 Ø	Seal-Choke/Throttle Shaft	1036		Label-Emissions (Available From A Briggs & Stratton Authorized Dealer)
635	691909	Boot-Spark Plug			
663	699854	Screw (Control Panel)			
668	694257	Spacer (Control Bracket)	1058	277104	Operator' Manual
668A	794539	Spacer (Snow Hood)	1070	794821	Screw (Flywheel Fan)
689	691855	Spring-Friction	1095	795200	Gasket Set-Valve
697	795012	Screw (Drive Cap)	1100	791959	Pivot-Rocker Arm
718	690959	Pin-Locating (Cylinder)	1119	699772	Screw (Alternator)
718A	695178	Pin-Locating (Cylinder Head)	1127	695407	Screw (Float Bowl)
725	696756	Shield-Heat	1138	694255	Nut (Control Bracket)
727	697465	Cover-Starter Drive	1171	794828	Stud (Rocker Cover)
731	794550	Hood-Snow	1196	699166	Screw (Snow Hood)
731A	793174	Hood-Snow	1196A	696692	Screw (Snow Hood)
732	699200	Screw (Starter Drive Cover)	1210	498144	Pulley/Spring Assembly (Pulley)
735	795901	Cord-Starter	1211	498144	Pulley/Spring Assembly (Spring)
741	691288	Gear-Timing	1230	699847	Stud (Control Bracket)
742	692564	Retainer-E Ring	1251	696762	Shield-Snow
746	694679	Gear-Idler	1251A	790471	Shield-Snow
751	794839	Washer (Stop Wire)	1252	699480	Screw (Snow Shield)
773	694258	Retainer	1288	794838	Nut (Snow Hood)
798	697890	Screw (Rocker Cover)	1318	698111	Knob-Snow Hood
832	795078	Guard-Muffler	1329	20P214-0015	Replacement Engine
836	699234	Screw (Muffler Guard)	1351	794847	Stud (Cylinder Shield)
847	695342	Dipstick/Tube Assembly	1352	795016	Nut (Spark Plug Shield)
851	692424	Terminal-Spark Plug	1427	695757	Cap-Pipe
868	794086 •+	Seal-Valve			
878	398661	Wire/Connector-Alternator			
883	695398 •+	Gasket-Exhaust			
892	791944	Switch-Key	•		Included in Engine Gasket Set, Key. No. 358
914	794827	Screw (Rocker Cover)	Ø		Included in Carburetor Overhaul Kit, Key. No. 121
930	696709	Guard-Rewind	+		Included in Valve Gasket Set, Key. No. 1095
957	795027	Cap-Fuel			
957A	698109	Cap-Fuel (Fuel Gage)			
972	694260	Tank-Fuel			

• Included in Engine Gasket Set, Key. No. 358  
 Ø Included in Carburetor Overhaul Kit, Key. No. 121  
 + Included in Valve Gasket Set, Key. No. 1095

**NOTE:** All component dimensions given in U.S. inches 1 inch = 25.4 mm

**Engine Power Rating Information**

The gross power rating for individual gas engine models is labeled in accordance with SAE (Society of Automotive Engineers) code J11940 (Small Engine Power & Torque Rating Procedure), and rating performance has been obtained and corrected in accordance with SAE J1995 (Revision 2002-5). Actual gross engine power will be lower and is affected by, among other things, ambient operating conditions and engine-to-engine variability. Given both the wide array of products on which engines are placed and the variety of environmental issues applicable to operating the equipment, the gas engine will not develop the rated gross power when used in a given piece of power equipment (actual "on-site" or net horsepower). This difference is due to a variety of factors including, but not limited to, accessories (air cleaner, exhaust, charging, cooling, carburetor, fuel pump, etc.), application limitations, ambient operating conditions (temperature, humidity, altitude), and engine-to-engine variability. Due to manufacturing and capacity limitations, Briggs & Stratton may substitute an engine of higher rated power for this Series engine.

---

# SERVICE NOTES

---

# Get it fixed, at your home or ours!

Just Call:

**1-800-4-MY-HOME<sup>®</sup>**

(1-800-469-4663)

24 hours a day, 7 days a week

For the repair of major brand appliances **in your own home...**  
no matter who made it, no matter who sold it!

For your nearest **Sears Parts and Service** location,  
to bring in products like vacuums, lawn equipment and electronics.

For **Sears Parts & Service**, to order the replacement parts,  
accessories and owner's manuals that you need to do-it-yourself.

[www.sears.ca](http://www.sears.ca)

---

To purchase or inquire about a Sears Maintenance Agreement, call:

**1-800-361-6665**

9 a.m. – 11 p.m. Mon. – Fri., EST, 9 a.m. – 4 p.m. Sat.

---

Pour service en français:

**1-800-LE-FOYER<sup>MC</sup>**

(1-800-533-6937)

[www.sears.ca](http://www.sears.ca)



02488

® / ™ Trademarks of Sears, Roebuck and Co. used under license by Sears Canada

<sup>MD</sup> Marque déposée / <sup>MC</sup> Marque de commerce de Sears, Roebuck and Co. utilisée en vertu d'une licence de Sears Canada