

## Tablet Computer Model No. FZ-G1 Series Operating Instructions - Reference Manual



We recommend that this Reference Manual be printed.

---

### Disclaimer

---

Computer specifications and manuals are subject to change without notice. Panasonic Corporation assumes no liability for damage incurred directly or indirectly from errors, omissions or discrepancies between the computer and the manuals. Refer for the latest information about optional products to the catalogs, etc.

---

### Trademarks

---

- Microsoft, Windows, and the Windows logo are registered trademarks or trademarks of Microsoft Corporation of the United States and/or other countries.
- Intel, Core, and PROSet are either registered trademarks or trademarks of Intel Corporation.
- microSDXC Logo is a trademark of SD-3C, LLC.



- MobileMark® is a U.S. Registered Trademark of the Business Applications Performance Corporation.
- The terms HDMI and HDMI High-Definition Multimedia Interface, and the HDMI Logo are trademarks or registered trademarks of HDMI Licensing Administrator, Inc. in the United States and other countries.
- Bluetooth® is a registered trademark owned by Bluetooth SIG, Inc., U.S.A. and licensed to Panasonic Corporation.
- Names of products, brands, etc., appearing in this manual are trademarks or registered trademarks of their respective own companies.

---

### About the Software License

---

This product incorporates the following software:

- (1) the software developed independently by or for Panasonic Corporation,
- (2) the software owned by third party and licensed to Panasonic Corporation, and/or
- (3) open source software

The software categorized as (3) is distributed in the hope that it will be useful, but WITHOUT ANY WARRANTY, without even the implied warranty of MERCHANTABILITY or FITNESS FOR A PARTICULAR PURPOSE. Please refer to the detailed terms and conditions thereof shown below.

## About zlib

/\* zlib.h -- interface of the 'zlib' general purpose compression library  
version 1.2.8, April 28th, 2013

Copyright (C) 1995-2013 Jean-loup Gailly and Mark Adler

This software is provided 'as-is', without any express or implied warranty. In no event will the authors be held liable for any damages arising from the use of this software.

Permission is granted to anyone to use this software for any purpose, including commercial applications, and to alter it and redistribute it freely, subject to the following restrictions:

1. The origin of this software must not be misrepresented; you must not claim that you wrote the original software. If you use this software in a product, an acknowledgment in the product documentation would be appreciated but is not required.
2. Altered source versions must be plainly marked as such, and must not be misrepresented as being the original software.
3. This notice may not be removed or altered from any source distribution.

Jean-loup Gailly    Mark Adler  
jloup@gzip.org    madler@alumni.caltech.edu

\*/

## About Lib PNG

This copy of the libpng notices is provided for your convenience. In case of any discrepancy between this copy and the notices in the file png.h that is included in the libpng distribution, the latter shall prevail.

COPYRIGHT NOTICE, DISCLAIMER, and LICENSE:

If you modify libpng you may insert additional notices immediately following this sentence.

This code is released under the libpng license.

libpng versions 1.2.6, August 15, 2004, through 1.6.3, July 18, 2013, are Copyright (c) 2004, 2006-2013 Glenn Randers-Pehrson, and are distributed according to the same disclaimer and license as libpng-1.2.5 with the following individual added to the list of Contributing Authors

Cosmin Truta

libpng versions 1.0.7, July 1, 2000, through 1.2.5 - October 3, 2002, are Copyright (c) 2000-2002 Glenn Randers-Pehrson, and are distributed according to the same disclaimer and license as libpng-1.0.6 with the following individuals added to the list of Contributing Authors

Simon-Pierre Cadieux  
Eric S. Raymond  
Gilles Vollant

and with the following additions to the disclaimer:

There is no warranty against interference with your enjoyment of the library or against infringement. There is no warranty that our efforts or the library will fulfill any of your particular purposes or needs. This library is provided with all faults, and the entire risk of satisfactory quality, performance, accuracy, and effort is with the user.

libpng versions 0.97, January 1998, through 1.0.6, March 20, 2000, are Copyright (c) 1998, 1999 Glenn Randers-Pehrson, and are distributed according to the same disclaimer and license as libpng-0.96, with the following individuals added to the list of Contributing Authors:

Tom Lane  
Glenn Randers-Pehrson  
Willem van Schaik

libpng versions 0.89, June 1996, through 0.96, May 1997, are Copyright (c) 1996, 1997 Andreas Dilger Distributed according to the same disclaimer and license as libpng-0.88, with the following individuals added to the list of Contributing Authors:

John Bowler  
Kevin Bracey  
Sam Bushell  
Magnus Holmgren  
Greg Roelofs  
Tom Tanner

libpng versions 0.5, May 1995, through 0.88, January 1996, are Copyright (c) 1995, 1996 Guy Eric Schalnat, Group 42, Inc.

For the purposes of this copyright and license, "Contributing Authors" is defined as the following set of individuals:

Andreas Dilger  
Dave Martindale  
Guy Eric Schalnat

Paul Schmidt  
Tim Wegner

The PNG Reference Library is supplied "AS IS". The Contributing Authors and Group 42, Inc. disclaim all warranties, expressed or implied, including, without limitation, the warranties of merchantability and of fitness for any purpose. The Contributing Authors and Group 42, Inc. assume no liability for direct, indirect, incidental, special, exemplary, or consequential damages, which may result from the use of the PNG Reference Library, even if advised of the possibility of such damage.

Permission is hereby granted to use, copy, modify, and distribute this source code, or portions hereof, for any purpose, without fee, subject to the following restrictions:

1. The origin of this source code must not be misrepresented.
2. Altered versions must be plainly marked as such and must not be misrepresented as being the original source.
3. This Copyright notice may not be removed or altered from any source or altered source distribution.

The Contributing Authors and Group 42, Inc. specifically permit, without fee, and encourage the use of this source code as a component to supporting the PNG file format in commercial products. If you use this source code in a product, acknowledgment is not required but would be appreciated.

A "png\_get\_copyright" function is available, for convenient use in "about" boxes and the like:  
`printf("%s",png_get_copyright(NULL));`

Also, the PNG logo (in PNG format, of course) is supplied in the files "pngbar.png" and "pngbar.jpg (88x31) and "pngnow.png" (98x31).

Libpng is OSI Certified Open Source Software. OSI Certified Open Source is a certification mark of the Open Source Initiative.

Glenn Randers-Pehrson  
glennrp at users.sourceforge.net  
July 18, 2013

**GOVERNMENT RESTRICTED RIGHTS.**

The Software is provided with "RESTRICTED RIGHTS." Use duplication or disclosure by the government is subject to restrictions as set forth in FAR52.227-14 and DFAR252. 227-7013 et seq. or their successors.

Use of the Software by the government constitutes acknowledgement of Intel's proprietary rights therein.

Contractor or Manufacturer is Intel Corporation, 2200 Mission College Blvd., Santa Clara, CA 95052.

Panasonic Corporation  
Osaka, Japan  
Web Site : <https://panasonic.net/cns/pc/>  
© Panasonic Corporation 2018



PS0918-0  
20180042ZAD

### Illustrations and Terminology in this Manual

- This manual explains using the default setting.
- Some illustrations and display examples may look different from the actual product.
- Some types of software are automatically updated, and differences may occur from descriptions in this manual.
- If you do not sign in as an administrator, you cannot use some functions or cannot display some screens.

Terms and illustrations in these instructions.

- CAUTION: Conditions that may result in minor or moderate injury.
- NOTE: Useful and helpful information.
- The display of the key may be different from this manual according to the keyboard used. (e.g. "Delete" instead of "Del")

- Touch  -  :

This description instructs the user to touch  (Start) first, and touch  (Power) next.

<Only when connected to the external keyboard>

- « Enter » : This means to press the « Enter » key.
- « Alt » + « Del » :  
This means to press and hold « Alt » key, and then press « Del » key.

In these instructions, the names are referred as follows.

- "Windows 10 Pro" as "Windows" or "Windows 10"
- "Multilanguage User Interface" as "MUI".
- The computer screen supporting touching methods (your fingers) is referred to as the "screen".

## Regarding Windows 10

### Desktop mode and Tablet mode

Windows 10 offers a desktop mode in which operations are performed via the keyboard, mouse, and touchpad, and a tablet mode that is optimized for touch panel operations.

The mode can be switched by touching  (Notification), and then touching  (Tablet mode).

### NOTE

- If some icons do not appear on the task tray, perform the following operations.
  1. Touch and hold the task tray.
  2. Select the item to display.

### Screen messages

Screen messages are explained in [English (United States)].

(Depending on the language preference, some screen messages in these instructions are different from the actual screen messages. For example, [Flight mode] may be displayed instead of [Airplane mode] in some language preference)

### Opening the Control Panel

On the Start screen, proceed as follows.

1. Touch  (Start) - [Windows System] - [Control Panel].

Alternatively, touch  (All apps) - [Windows System] - [Control Panel] in the tablet mode.

### Opening the “Settings” screen

1. Touch  (Start) -  (Settings).

Alternatively, touch  (Settings) in the tablet mode.

### Opening the Panasonic PC Settings Utility

On the Start screen, proceed as follows.

1. Touch  (Start) -  (Panasonic PC Settings Utility).

Alternatively, touch  (Panasonic PC Settings Utility) in the tablet mode.

### Notification area

The notification area is on the right side of the screen.

To display the notification, touch  (Notification) on the task tray.

### Latest Information on Windows 10

When Windows 10 is updated, the screen display or operation procedures may be changed.

For the latest information on Windows 10, see the following web page.

<https://pc-dl.panasonic.co.jp/itn/addendum/>

## Sound and Video

- Sound (e.g. MP3, WMA) and video (e.g. MPG, WMV) recorded in microSD Memory Card may be interrupted during playback. If this happens, copy them to the flash memory drive and play back.
- Depending on the processing status on Windows, sound may be interrupted at Windows startup. You can mute the sound at startup. The startup sound is muted as the factory default.

1. Touch and hold  (Speaker) on the task tray, and touch [Sounds].
2. Remove the check mark from [Play Windows Startup sound], and touch [OK].

### When high-frequency sound occurs

If high-frequency sound occurs while using the computer, check the settings for the USB power saving function.

- Set [USB selective suspend setting] to [Enabled].

1. Touch  (Start) -  (Settings) - [System] - [Power & sleep] - [Additional power settings].

Alternatively, touch  (Settings) - [System] - [Power & sleep] - [Additional power settings] in the tablet mode.

2. Touch [Change plan settings] of the current power plan.
3. Touch [Change advanced power settings].
4. In [Advanced settings], double-touch [USB settings].
5. Double-touch the displayed [USB selective suspend setting].
6. Change settings of [On battery] and [Plugged in] to [Enabled].
7. Touch [OK] and exit the “Power Options” screen.

The ambient light sensor is used to adjust the display screen brightness automatically. To configure the automatic adjustment function, proceed as follows.

1. Touch  (Start) -  (Settings) - [System] - [Display].

Alternatively, touch  (Settings) - [System] - [Display] in the tablet mode.



2. Add the check mark to [Change brightness automatically when lighting changes] under "Brightness and color".

---

## Windows Update

---

You can update to the latest patches and service packs for Windows with the following menus.

1. Touch  (Start) -  (Settings) - [Update & Security] - [Windows Update].

Alternatively, touch  (Settings) - [Update & Security] - [Windows Update] in the tablet mode.

2. Touch [Check for updates].

Do not apply "Driver Updates" even if a message to update a driver appears. If a driver update is required, contact your technical support office.

## Create a Recovery Disc

You can make a recovery disc for preinstalled software.

The recovery disc returns the flash memory to the factory default. To create a backup of the recent state of the flash memory, refer to [Flash Memory Backup/Restore Function](#).

### Preparation

- Blank discs (About usable types of discs and required numbers of discs, refer to the screen.) or USB storage device.
- When using DVD media to create a recovery disc, prepare the commercially available optical drive.
- USB memory device can also be used as a recovery disc.
- Connect the AC adaptor and do not remove it until the operation is complete.
- Close all applications except for this utility.
- Remove all peripherals (excluding the device that will be used to create the recovery disc).
- Turn off the wireless function.

## NOTE

- **If the recovery partition is deleted, you cannot create recovery disc(s).**

<When using a USB storage device to create a recovery disc>

- Any previously existing data stored on the USB storage device will be deleted.
- USB storage devices with capacities insufficient for creating a recovery disc cannot be used.
- USB storage devices that are partitioned cannot be used.
- USB storage devices that are recognized as SCSI (i.e., UASP\*1 devices) cannot be used.

\*1 : USB Attached SCSI Protocol.

- **USB memory device can also be used as a recovery disc.**
- **Do not perform the following operations until creating the recovery disc is complete.**
  - Shut down or restart Windows.
  - Enter sleep or hibernation.
  - Remove the commercially available optical drive or USB storage device being used for recovery disc creation.
- **If you interrupted creating a recovery disc, a message of failure may appear in step 10 screen below. In this case, restart the computer, and create a new recovery disc again.**

1. **Sign in to Windows as an administrator.**
2. **Connect the device being used to create the recovery disc to the unit.**
  - For DVD media
    1. Connect the commercially available optical drive to the USB Port.
    2. Insert the disc into the commercially available optical drive.
  - For USB storage devices
    1. Connect the USB storage device to the USB port.



3. Touch  (Start) -  (Panasonic PC Recovery Disc Creation Utility).

If the "User Account Control" screen appears, touch [Yes].

4. Touch [Next].
5. Confirm on-screen information ([Select OS Image] and [Number of discs required]), and then touch [Next].
6. Select the drive, and in the case of DVD media, select the disc type.
7. Touch [Next].
8. In the case of DVD media, select the [Write speed].

9. **Touch [OK]**

Creation of the recovery disc (i.e., writing) starts. Wait a moment for the process to complete.

10. **Finish creation of the recovery disc as follows.**

- For DVD media
  1. Remove the disc when “Recovery disc #1 complete.” appears, and label the disc to avoid losing it. Do not use sharp objects that may leave a mark.
  2. If the recovery disc spans multiple discs, insert the next disc.
  3. Touch [OK].
  4. Follow the on-screen instructions to create all the recovery discs.
  5. Touch [OK] on the “All recovery discs complete.” screen.
- For USB storage devices
  1. Touch [OK] on the “All recovery discs complete.” screen.
  2. Perform “Safely Remove Hardware and Eject Media”, and remove the USB storage device.

---

**NOTE**

- **The disc created with this utility is only for this computer. You cannot use for others.**
  - **Additional applications cannot be recovered even if you use a recovery disc created with this utility.**
  - **If you fail to create a recovery disc or an error message appears, try either of the following procedures.**
    - Insert the disc or USB storage device correctly.
    - Check the disc or USB storage device condition.
    - Restart the computer and try to create a recovery disc again.
    - Contact Panasonic Technical Support.
-



- Do not add or delete partitions in Windows 10, as the Windows area and recovery partition must be adjacent to each other in Windows 10.

## Flash Memory Backup/Restore Function

Panasonic Corporation will bear no responsibility for any damage suffered (including loss of data) as a result of the use of this function.

### Creating a Backup of the Flash Memory Data

You can create a backup of the flash memory data, which can be used to recover from hardware failure.

This function creates a backup of the recent state of the flash memory. To return the factory default, use a recovery disc. (  [Create a Recovery Disc](#))



To create a backup of the flash memory to another storage media (e.g., external hard disk).  
Connect the storage media, and follow the steps below.

1. **Open the Control Panel, and then touch [System and Security] - [File History].**
2. **Touch [System Image Backup].**
3. **Touch [Create a system image].**  
Follow the on-screen instructions.

#### NOTE

- Connect the AC adaptor and do not remove it until backup is complete.

### Restoring the Flash Memory Data

1. Touch  (Start) -  (Settings) - [Update & Security] - [Recovery].
2. Touch [Restart now] under "Advanced startup"\*1.
3. Touch [Troubleshoot] - [Advanced options].
4. Touch [System Image Recovery].  
Follow the on-screen instructions.

\*1 : Screen messages are explained in [English (United States)].

(Depending on the language preference, some screen messages in these instructions are different from the actual screen messages. For example, [Advanced start-up] may be displayed instead of [Advanced startup] in some language preference.)

## Description of Parts

### Front side

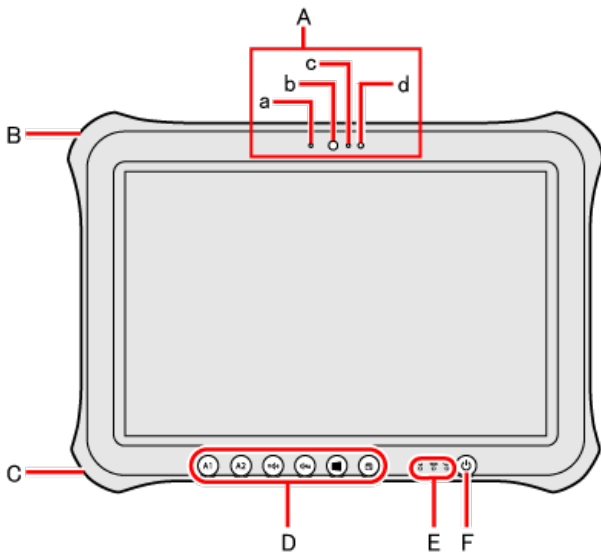

#### A. Front Camera

<Only for model with Front Camera>

(  [Camera](#) )

- a. Camera Lens
- b. Camera Indicator
- c. Microphone
- d. Ambient Light Sensor

The ambient light sensor is equipped with an automatic brightness adjustment function that adjusts the display screen. (  [Automatic brightness adjustment](#) )

#### A. IR Camera

<Only for model with camera with IR sensor>

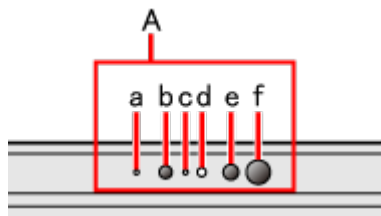

- a. Camera Indicator
- b. Camera Lens
- c. Microphone
- d. Ambient Light Sensor
- e. IR Camera
- f. IR camera lights (RED)

The ambient light sensor is equipped with an automatic brightness adjustment function that adjusts the display screen. (  [Automatic brightness adjustment](#) )

#### B. Security slot

A Kensington cable can be connected.

For further information, read the manual that comes with the cable.

#### C. DC-IN Jack

#### D. Tablet Buttons

(  [Tablet Buttons](#) )

#### E. LED Indicators



: Power Indicator

- Off: Power off/Hibernation
- Green: Power on
- Blinking green: Sleep
- Blinking green and orange: Cannot power on or resume due to low temperature.



: Drive Indicator (Drive status)



: Battery Indicator (Battery status)

( → [When the battery indicator does not light on](#))

( → [Battery Power](#))

## F. Power Switch

### Right side

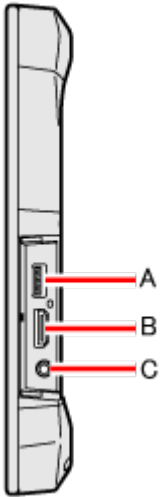

#### A. USB 3.0 port

( → [USB Devices](#))

#### B. HDMI Port

( → [External Display](#))

#### C. Headset Jack

A headset or headphone can be connected.

### Rear side

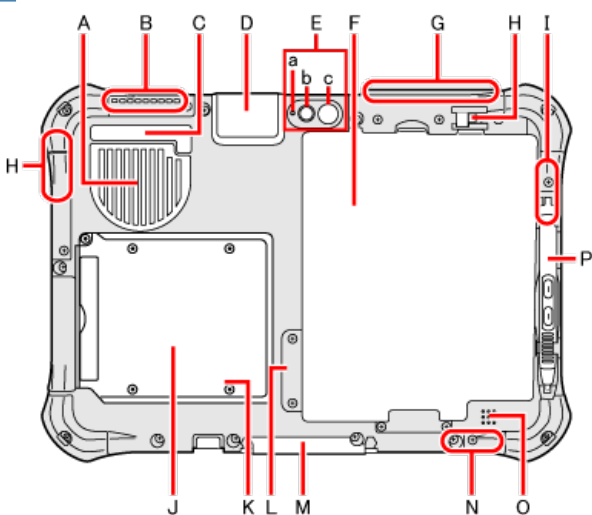













#### A. Ventilation Hole (Intake)

#### B. Ventilation Hole (Exhaust)

#### C. Dust Cover

( → [Handling and Maintenance](#))

- D. **USB 2.0 port / LAN Port / Serial Port / microSD Memory Card Slot / GPS / Thermography Camera**  
 <Only for model with 2nd USB port>  
 (  [USB Devices](#))  
 <Only for model with LAN Port>  
 (  [LAN](#))  
 <Only for model with Serial Port>  
 (  [Serial Port](#))  
 <Only for model with microSD Memory Card Slot>  
 (  [microSD Memory Card](#))  
 <Only for model with dedicated GPS / GPS on wireless WAN>  
 (  [GPS](#))  
 <Only for model with Thermography Camera>  
 For more information, refer to “Using the Panasonic PC Thermal Viewer”.
- E. **Rear Camera**  
 <Only for model with Rear Camera>  
 (  [Camera](#))
- a. **Camera Indicator**
  - b. **Camera Lens**
  - c. **Camera Light**
- F. **Battery Pack**
- G. **Wireless LAN Antenna / Bluetooth Antenna**  
 <Only for model with wireless LAN>  
 (  [Wireless LAN](#))  
 <Only for model with Bluetooth>  
 (  [Bluetooth](#))
- H. **Battery Latch**  
 (  [Battery Power](#))
- I. **Wireless WAN Antenna**  
 <Only for model with wireless WAN>  
 (  [Wireless WAN](#))
- J. **Smart Card Reader / Magnetic Stripe Card Reader / Contactless Smart Card Reader / Built-in Bridge Battery**  
 <Only for model with Smart Card Reader>  
 (  [Smart Card](#))  
 <Only for model with Magnetic Stripe Card Reader>  
 (  [Magnetic Stripe Card Reader](#))  
 <Only for model with Contactless Smart Card Reader>  
 (  [Contactless Smart Card Reader/RFID Reader](#))  
 <Only for model with Built-in Bridge Battery>  
 (  [Battery Power](#))
- K. **LED Indicators**  
 <Only for model with Built-in Bridge Battery>  
 (  [Battery Power](#))
- L. **nanoSIM Card Slot**  
 <Only for model with wireless WAN>  
 (  [Wireless WAN](#))
- M. **Expansion Bus Connector**  
 (  [Cradle](#))
- N. **Wireless LAN Antenna**  
 <Only for model with wireless LAN>  
 (  [Wireless LAN](#))
- O. **Speaker**

## P. Digitizer pen / Pen Holder

Bottom Side

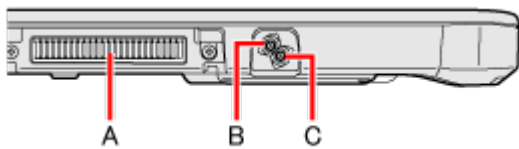



- A. Expansion Bus Connector
- B. External Antenna Connector (EXT\_ANT1)
- C. External Antenna Connector (EXT\_ANT2)

## NOTE



- The following factory preset combinations are available for the external antenna output.

EXT_ANT1	EXT_ANT2
WWAN main	Dedicated GPS
	WWAN-GPS
	WLAN main

### Turning On



Press and hold the power switch  until the power indicator  lights. (  [Description of Parts](#) )

#### NOTE

- Do not press the power switch repeatedly.
- The computer will forcibly be turned off if you press and hold the power switch  for four seconds or longer.
- Once you turn off the computer, wait for ten seconds or more before you turn on the computer again.
- Do not perform the following operation until the drive indicator  turns off.
  - Connecting or disconnecting the AC adaptor
  - Pressing the power switch
  - Touching tablet buttons, screen or external mouse



### Turning Off

Shut down the computer.

1. Touch  (Start) at the bottom left corner.
2. Touch  (Power) - [Shut down].

#### NOTE

To turn off the computer completely, proceed as follows.

1. Touch  (Start) -  (Settings) - [Update & Security] - [Recovery].
2. Touch [Restart now] under "Advanced startup".
3. Touch [Turn off your PC].

### Precautions against Starting Up/Shutting Down

Do not do the following

- Connecting or disconnecting the AC adaptor
- Pressing the power switch
- Touching tablet buttons, screen or external mouse

#### NOTE

---

■ **To conserve power, the following power saving methods are set at the time of purchase.**

- The screen automatically turns off after :
  - 10 minutes (when AC adaptor is connected) of inactivity
  - 5 minutes (when operating on battery power) of inactivity
- The computer automatically enters sleep<sup>\*1</sup> after :
  - 20 minutes (when AC adaptor is connected) of inactivity
  - 15 minutes (when operating on battery power) of inactivity

\*1 : Refer to "[Sleep/Hibernation Functions](#)" about resuming from sleep.

---



## Screen Input Operation

The screen of your computer allows you to perform the same operations as a mouse by touching its surface. The computer supports, using your fingers and the digitizer pen (included).

### NOTE

- Note that the touch screen may respond to the following:
  - Putting the digitizer pen (included) or finger close to the screen.
  - Liquid or metallic objects other than the digitizer pen (included) or finger.

### Attaching the pen to the computer

- Insert the (A) section (tip) of the pen into the (B) section of the pen holder, and then insert the rest of the pen in the pen holder securely.

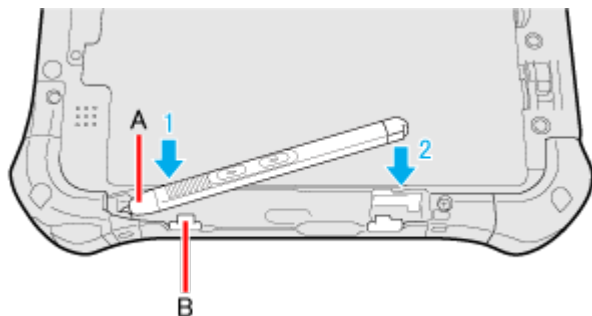

### Detaching the pen from the computer

- Lift the (C) section of the pen to remove it from the pen holder.

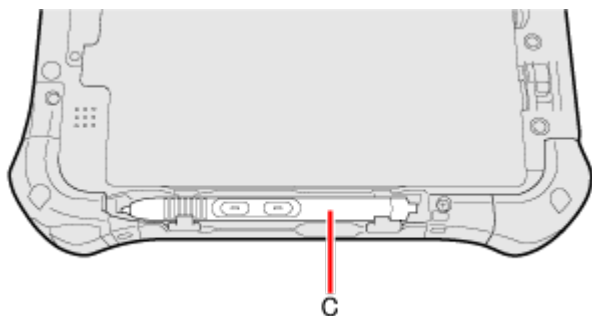

### Using the digitizer pen (included)

- We recommend placing the digitizer pen (included) perpendicular to the screen surface when using it.

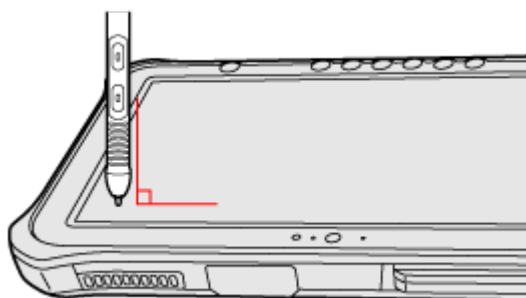

- Press the digitizer pen's tip on the screen surface, and use the pen.

### To operate "touch and hold" ("right-click")

- Touch and hold the object with your fingers, or the digitizer pen (included), and release it when a flame surrounding the object appears.
- Press and hold the button (A) of the pen (included), and then touch the object.

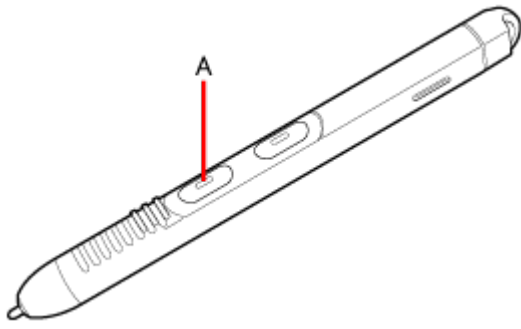

**To operate “eraser” with the pen (included)**

- Press and hold the button (B) of the pen (included), and then touch the object.

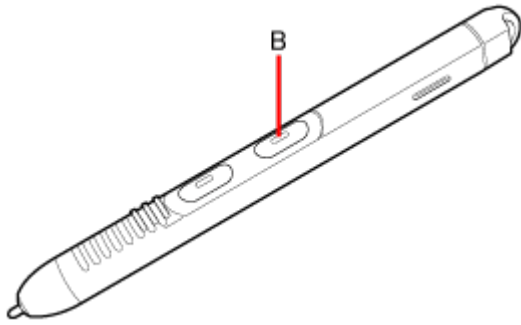

**Operation by touching the screen**

Instead of operating the screen with the pointer, you can use your fingers.  
 This computer supports multi touch of ten points or less at the same time.

A line drawing showing a hand with one finger touching a rectangular screen. A small black arrow points from the finger to the point of contact on the screen.	<p>Touch (Tap)</p>	<p>Touch the screen once with one finger.</p>
Two line drawings showing hand gestures on a screen. The top drawing shows two fingers touching a screen with two arrows pointing outwards from the contact points, indicating a 'spread' gesture. The bottom drawing shows two fingers touching a screen with two arrows pointing inwards towards the contact points, indicating a 'pinch' gesture.	<p>Spread / pinch</p>	<p>Touch an image or document with two fingers, and spread your fingers apart to zoom in or pinch them together to zoom out.</p>

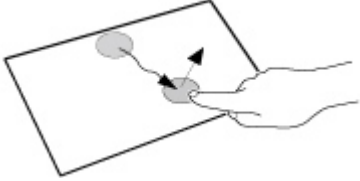
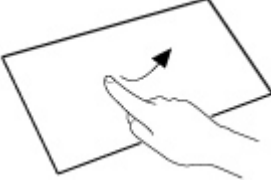
	Drag	Touch an object (file, icon, etc.) and drag your finger to the desired location before removing it to move the object.
	Swipe	Touch with a sweeping motion.
	Flick	Touch with a quick sweeping motion.

## Touch Screen Mode

You can select the suitable operation mode in Touch Screen Mode.

1. Touch  (Start) -  (Panasonic PC Settings Utility) -  (Settings) -  (Touch Screen).

2. Select the operation mode under "Touch Screen Mode".

### [Touch] mode

- Suitable for finger operation and the digitizer pen (included) operation.

### [Touch (Glove)] mode

- Use this mode when operating with a glove on.
- Depending on the type of glove, operation may be ignored.
- With finger operation, the screen may not respond properly.

### [Touch (Water)] mode

- Use this mode when the screen or finger is wet with water drops in operation.
- Depending on the water drop condition, operation may be ignored.
- Operation may not be performed correctly around the edges of the screen.

3. If a confirmation message appears, touch [Yes].

## NOTE

- You cannot use the pen regardless of the setting before Windows is started up.
- You cannot use the pen with the operations other than the Windows (PIN input of Bitlocker, operating screen from Recovery Drive, etc.) even if the pen operation mode is set.
- When "Touch Screen Mode" is set to [Touch (Water)], multi touch input is reduced to 2 points.
- You can reset the touch screen by pressing Windows button when the touch screen cannot be used or the pen cannot be used in the [Touch] / [Touch (Glove)] / [Touch (Water)] mode.

## Calibrating the Screen

Perform calibration as follows in the following cases.

- If accurate pointing with your fingers or the digitizer pen (included) is not possible.
- If the cursor jumps to a different position of the screen from where you touch it.
- If the LCD resolution changes.

- Change the display mode to the landscape before starting screen calibration. If calibration is performed other than the landscape, it may not be possible to touch the target marks correctly.

## NOTE

- At first, sign in to Windows as an administrator, and perform this calibration.

1. Set the touch screen mode to [Touch]. (  [Touch Screen Mode](#))
2. Open the Control Panel, and then touch [Hardware and Sound] - [Tablet PC Settings].
3. Touch [Reset].  
If you cannot touch [Reset], perform the following step 4.
  - Reset the calibration data.
    1. At the confirmation message, touch [Yes].
    2. Touch reset the data of [Touch input] or [Pen input].

## NOTE

- We recommend using [Touch input] at the factory default.

4. Touch [Calibrate].  
If [User Account Control] is displayed, touch [Yes].
5. Touch [Pen input] for the pen (includes) or [Touch input] for your finger.
6. Using the pen (included) or finger, touch each of the “+” target marks one by one, and then touch [Yes].

## NOTE

- Make sure digitizer pen (included) is perpendicular to the screen to get the most accurate calibration.

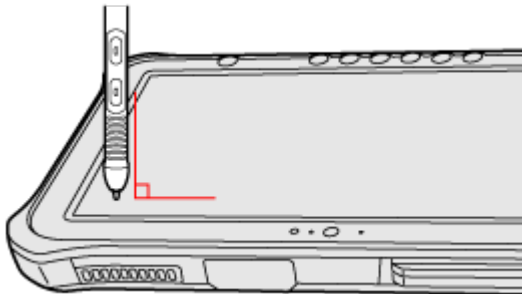

- If you perform calibration as a standard user, the calibration data is valid until you sign out (the data becomes invalid after you have signed out). When using the computer continuously, perform calibration as an administrator.
- If you cannot operate the computer correctly after calibration, delete the calibration data by touching [Control Panel] - [Hardware and Sound] - [Tablet PC Settings] - [Reset], and perform calibration again. (Be sure to delete the calibration data as an administrator.)

## NOTE

- The following message, “Right-click anywhere on the screen to return to the last calibration point. Press the Esc button to close the tool.” will appear on the center of the screen during calibration. However, the operation to close the tool by pressing the « Esc » key can be performed only when an external keyboard is connected.
- If you cannot touch the desired position, perform calibration again and restart the computer.

## About Touch Operation Support

Touch Operation Support is an application that allows you to perform screen operations more easily. When you use a two-finger tap gesture to specify the area in which you want to perform touch operations, the area is displayed in a zoom window, allowing you to perform touch operations in an expanded display.

### Using Touch operation support settings

#### Important usage notes

- This application will only operate on internal screen displays.
- Using the two-finger tap gesture may not display the zoom window in certain applications that handle touch operations independently (e.g., Microsoft Office Word, Internet Explorer and Paint).
- This application may take some time to start after sign in.
- You cannot use the two-finger tap gesture to display the zoom window unless this application is running.
- Using the two-finger tap gesture will not display the zoom window in some applications (Magnifier (Windows), Touch Keyboard (Windows), On-Screen Keyboard (Windows), etc.).

#### Expanding a portion of the display

When you use a two-finger tap gesture to specify the area in which you want to perform touch operations, the area is displayed in a zoom window, allowing you to perform touch operations in an expanded display.

### Opening the zoom window

1. **Perform a two-finger tap on the area of the screen you want to expand.**

A rectangular zoom window with a diagonal length equal to the distance between the two tapped points appears.

(1) Perform two-finger tap.

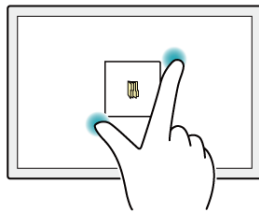

(2) Display expands.

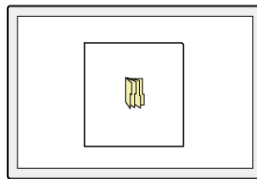

You can quickly expand the corner of the screen, for example, by performing a two-finger tap with both fingers joined.

(1) Tap with two fingers joined.

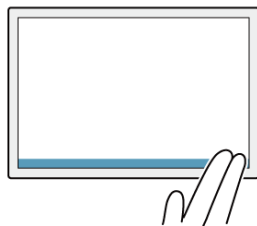

(2) Display expands.

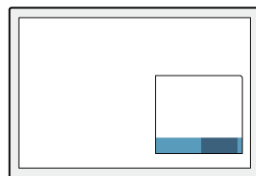

2. **Perform touch operations in the zoom window.**

## NOTE

You can perform the following touch operations in the zoom window.

- Tap (Left Click)
- Double Tap (Left Double Click)
- Press and Hold (Right Click)
- Tap on the popup menu to be displayed after right touch
- Drag (Drag by Left Button)

- 
- Drag after Press and Hold (Drag by Right Button)
  - Drag from inside to inside of the zoom window
  - Drag from inside to outside of the zoom window
  - Drag from outside to inside of the zoom window
  - Drag from outside to outside of the zoom window
- 

Operation guides may appear when using the zoom window for the first time. These guides will not appear again if you select the [Do not show this again] checkbox and tap [OK].

## NOTE

- If two points that will result in a zoom window size that is larger than the resolution of the screen are tapped, the zoom window will be adjusted to fit the screen.
  - Even if you use a two-finger tap gesture on a small rectangular area, the zoom window cannot be displayed in a size smaller than the pre-determined minimum size.
  - The zoom window may not appear if you perform a two-finger tap on a window's title bar or edges or on an unfixed taskbar.
  - The zoom window may also appear when you tap using three fingers.
  - If a button for another application, for example, exists within the area of the two-finger tap, the button may be activated in addition to the zoom window opening in some cases.
  - You can also use mouse and perform operation inside the zoom window. In that case, the displayed area in the zoom window follows mouse cursor movement.
- 

## Closing the zoom window

1. **Tap outside the zoom window.**  
The zoom window closes.

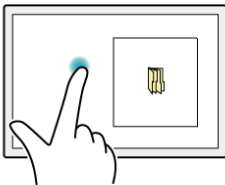

## NOTE

- If you are displaying the edge of the screen in the zoom window and you tap the edge of the screen outside the zoom window, an operation identical to that inside the zoom window may be performed and the zoom window may not close in some cases.
  - The zoom window automatically closes when:
    - You disable the utility in the task tray menu
    - You rotate the screen
    - You change the resolution
    - Computer enters into the hibernation mode
    - The screen is locked
    - A user is switched
    - The desktop size (taskbar width, etc.) is changed
    - An additional zoom window is opened
    - Any of the applications that cannot be used together is launched
- 

## Changing the position of the zoom window

The zoom window cannot be moved.

To change the area displayed in the zoom window, close the zoom window and perform the steps in [“Opening the zoom window”](#) to expand the display again.

## Additional functions

Touch operation support settings include the following helpful functions for when you press and hold or drag and drop a folder or file.

### Context menu displays

When you perform a press and hold gesture in a zoom window to display a context menu, for example, the zoom window will be automatically adjusted to display the whole context menu.

### NOTE

- This function cannot be used in some applications.

### Drag and drop operations

When you drag a folder or file from inside a zoom window to the outside, the zoom window will disappear temporarily and a dotted line will appear around the object being dragged.

As you drag the object to its target location, the area of the target location will be displayed in expanded view automatically, allowing for easier drop operations.



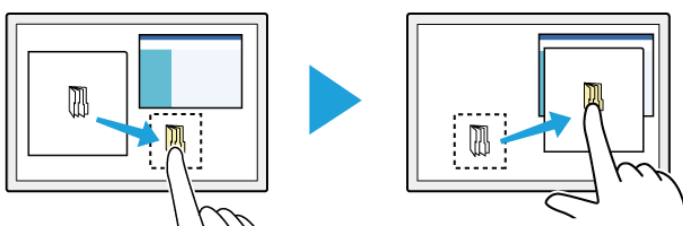

(1) Drag outside.



(2) Dotted line appears.

(3) Expanded view appears when you slow your drag speed.

## Changing settings

1. Touch  (Start) -  (Panasonic PC Settings Utility) -  (Settings) -  (Touch Screen).
2. Touch [Advanced Settings] under "Touch Operation Support".
3. Adjust each setting.







- A. Use the slider to change the zoom ratio of the window (4 levels in 0.5x increments).
  - B. If you clear the checkbox, the zoom window will continue to be displayed when you tap inside the zoom window. If you select the checkbox, the zoom window will close when you tap inside the zoom window.
  - C. If you select the [Display Operation Guides] checkbox and touch [OK] to close the window, operation guides will appear the next time you perform a two-finger tap after signing in.
  - D. Touch this to restore changed values to default settings.
4. Touch [OK].  
This completes settings adjustment.

## NOTE











- Specifying a zoom ratio other than 2.0x or 3.0x may cause text in the zoom window to appear unclear.
- When the setting window is displayed, the zoom window will not be displayed.

## Disabling Touch Operation Support

1. Touch  (Start) -  (Panasonic PC Settings Utility) -  (Settings) -  (Touch Screen).
2. To disable "Touch Operation Support", remove a checkmark to "Support touch operation".







## Tablet Buttons

Button	Function
	<p><b>Power</b> Start/Turn off the computer.</p>
	<p><b>Windows</b> Same as Windows key.</p> <p><b>NOTE</b></p> <ul style="list-style-type: none"> <li>The Windows button does not function when pressed together with a specific key on the external keyboard.</li> <li>You can enable or disable the key with Setup Utility.</li> </ul>
  	<p><b>Volume</b></p> <p><b>NOTE</b></p> <ul style="list-style-type: none"> <li>You can set the key to either Volume Up/Down or Brightness Up/Down with Setup Utility.</li> </ul>
	<p><b>Rotation Lock</b> (  <a href="#">Display Rotation</a> ) Automatic display rotation ON/OFF.</p>
	<p><b>A1</b> Panasonic PC Settings Utility ON/OFF. &lt;Only when [Concealed Mode] is set to [Enabled]&gt; Concealed Mode ON/OFF. (  <a href="#">Concealed Mode</a> )</p> <ul style="list-style-type: none"> <li>You can select on/off of LCD backlight, LED, Sound, Wireless Radio, Fan, Camera light<sup>*1</sup>, Camera Flash<sup>*1</sup> and Barcode Reader light<sup>*2</sup>. The camera indicator cannot be turned off.</li> </ul> <p>*1 : Only for model with Rear Camera. *2 : Only for model with Barcode Reader.</p> <p><b>NOTE</b></p> <ul style="list-style-type: none"> <li>You have to set [Concealed Mode] to [Enabled] in Setup Utility to control Concealed Mode with this button operation.</li> <li>You can set the devices turned off in [Concealed Mode] with Setup Utility.</li> </ul> <p> If you press  in succession, the Concealed Mode may not be switched. More than 4 seconds interval is necessary to switch on/off.</p>
	<p><b>A2</b> &lt;Only for model with Barcode Reader&gt; Read the barcode. &lt;Only for model without Barcode Reader&gt; Touch keyboard appears.</p>

## NOTE

- You can use the Tablet buttons instead of following keys when the Windows screen is not displayed.

Tablet Buttons	Keyboard
	→
	↓
	« Enter »
	« ESC »
	« F2 » *3

\*3 : Can be changed using [A2 Button] in the [Main] menu - [Tablet Buttons Configuration] of the Setup Utility.

- The Tablet buttons may not work immediately after Windows is started up or the Windows sign in screen (or the Welcome screen) is displayed.





## Setting the Tablet Buttons

### NOTE

- You can have different settings for each user.
- On the Windows sign in screen and Welcome screen, the tablet buttons are enabled and work in default irrespective of the settings you made.

### To change the button functions

You can change the functions of  ,  and  buttons.

1. Touch  (Start) -  (Panasonic PC Settings Utility) -  (Settings) -  (Button / Key).
2. Touch [Settings] under "Tablet Buttons".
3. Select the "Tablet button" and touch [Change].  
Alternatively you can open "Tablet PC Settings" by the following procedure:  
Open the Control Panel, and then touch [Hardware and Sound] - [Tablet PC Settings] - [Buttons].
4. Select the function in [Press:] and [Press and hold:].
  - In the case of tablet button "A1", touch [Browse] to select the application if you select [Start a program].
5. Touch [OK].
6. Touch [OK].

### NOTE

- If you touch [Reset], the setting will be the factory default.
- You can also open the setting screen by the following steps.

- 
- Touch  (Start) - [Windows System] - [Control Panel] - [Hardware and Sound] - [Set tablet buttons to perform certain tasks] under "Tablet PC Settings".
-

## Important Tips

### Important Battery Tips

#### NOTE

<Only for model with Built-in Bridge Battery>

- The computer is equipped with a built-in bridge battery (not replaceable) and a battery pack (replaceable).

#### How to use the battery with minimal deterioration

The battery is a consumable and, as such, its performance will gradually deteriorate. This deterioration is accelerated under the following conditions.

- **When the battery is repeatedly charged**
- **When the battery is used, charged or stored in a place with high temperature**

To minimize deterioration of the battery and ensure a longer battery life, you must reduce the number of charges and ensure that the temperature inside the battery does not become too high. Bear in mind the following points.

#### NOTE

- The battery pack gradually deteriorates over time even if cared following the above points. If it deteriorates, be sure to replace with a new and specified battery pack.
- This computer reduces the full charge capacity in stages to ensure a longer life of the battery pack.

#### Charge the battery in a temperature range of 10°C to 30°C {50°F to 86°F}

In places where the outside air temperature is high, the temperature inside the battery will also become high. Do not charge the battery inside a vehicle with all its windows closed and exposed to the hot sun or in other places where the temperature is high.

This computer's battery will not be charged if its temperature is outside the allowable range. (At such a time, the battery indicator blinks orange.)

#### We recommend charging the battery no more than once per day

Recharging the battery after every small use raises the total number of battery charges and speeds battery deterioration.

To lower the total number of battery charges, we recommend recharging the battery no more than once per day or when the remaining charge drops to 10% or less.

With this computer, in order to reduce the number of charges, the battery will not be recharged immediately after it has been fully charged unless the remaining charge has fallen to less than 95 %.

#### Charging the battery while the computer is powered off is recommended

If the computer's power is on, the temperature inside the battery rises due to the effects of heat from the CPU and other components. We recommend that you only charge the battery when the computer is powered off.

#### How to use the computer to maximize the battery operation time

##### Leave the computer off when it is not in use

Touch  or  on the task tray, and then touch , decrease the internal LCD brightness

Decreasing the brightness reduces the power consumption.

##### Before stepping away from your computer, enter the sleep or hibernation mode

Refer to [Entering/Resuming from Sleep or Hibernation](#).

Touch  or  on the task tray, and then move the "Power mode" slider () to the left to set the "Power mode" to "Best battery life".

This will reduce power consumption.

## We recommend against using applications or screen saver that place a significant load on the CPU

Some screen savers place a large load on the CPU. When using these screen savers, a significant load is placed on the CPU even when the computer is not being used. We recommend that you do not use screen saver that will drain the CPU.

## Remove peripheral devices (USB devices, external mouse, etc.) when not in use

## When the network communication is not working, turn off the wireless LAN

## When the computer is not going to be used for an extended period (a month or more)

### In order to maintain the battery performance, remove the battery with a remaining charge of 30% to 40% from the computer, and store it in a cool, dark place

If the battery pack is kept installed in the computer, it will discharge gradually even when the computer's power is off. If this condition continues for a long period (several months or more), the battery may overdischarge, causing its performance to deteriorate. In addition, this deterioration will accelerate if the battery pack is stored inside a vehicle with all its windows closed and exposed to the hot sun or in other places where the temperature is high. Store the battery pack where the temperature is within the range of 10°C to 30°C {50°F to 86°F}.

## Things to keep in mind when using the battery pack

### Bear in mind the following points when installing and removing the battery pack

- Do not install or remove the battery pack while the computer is in the sleep mode. (Only for model without built-in bridge battery)  
Removal of the battery pack in this mode cause the data to be erased and cause the computer to malfunction.
- Do not touch the terminals on the battery pack.  
If the terminals are dirty or damaged, the battery may not function properly or the computer may not operate properly.

### Charging time and discharging time differs depending on the computer's power status and temperature

- It takes longer to fully charge the battery when the computer's power is on. To charge the battery more quickly, power the computer off, or put it in the sleep or the hibernation mode.
- It takes longer to fully charge the battery in low temperature environments. The battery discharges more quickly in low temperature environments.

## Battery Indicator

Battery indicator (A): 

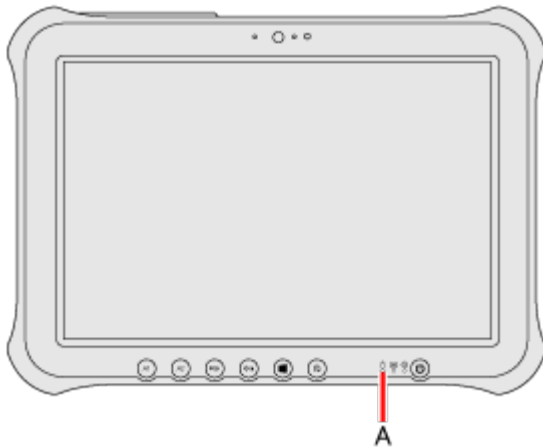

Battery indicator	Battery status
Not lit	<ul style="list-style-type: none"> <li>The battery pack is not inserted or not being charged.</li> <li><a href="#">Concealed Mode</a> is set to ON.</li> </ul>
Orange	Charging is in progress. If <a href="#">Battery Charging Indicator</a> in the [Main] menu of the Setup Utility is set to [Flashing], the indicator will alternately become lighter and darker (Flashing).
Green	The battery is fully-charged.
Blinking green	In order to stop the battery from deteriorating, power supply from AC adaptor has been shut off, and the battery power is being consumed. Do not remove the battery pack in this status.
Red	The remaining battery is approximately 9% or less.
Blinking red	The battery pack or the charging circuit is not operating properly. Remove the battery pack immediately.
Blinking orange	The battery cannot be charged temporarily due to the following reasons: <ul style="list-style-type: none"> <li>Its internal temperature is out of the acceptable range.</li> <li>The power supply is not enough because software applications or peripheral devices are consuming a large amount of power.</li> </ul>
Blinking green and orange alternately	The temperature is low and the computer is warming up to prevent the flash memory drive from malfunctioning. The computer will start automatically after warming-up.
Blinking orange slowly	When you set <a href="#">Battery Charging Indicator</a> to [Flashing] on the "Main" menu of Setup Utility.

<Only for model with Built-in Bridge Battery>

Battery indicator (B)

Latch (C)

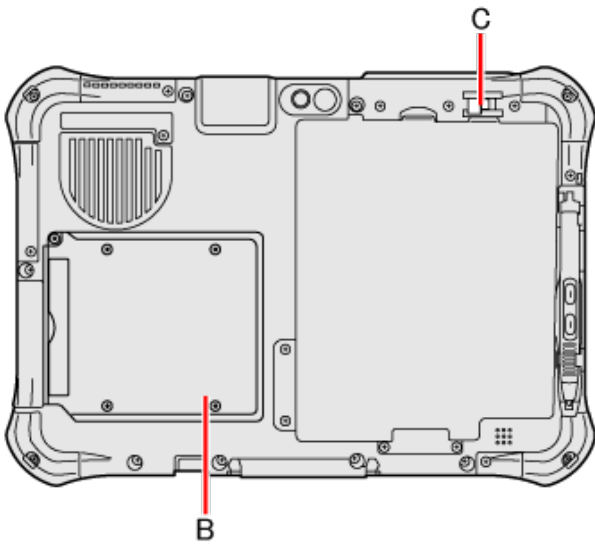

Battery indicator	Battery status
<b>Green</b>	The battery pack can be replaced. (When the battery latch (C) is slid with the AC adaptor disconnected)
	Only for model with built-in bridge battery The battery pack can be replaced. (When the AC adaptor disconnected, the built-in bridge battery discharges.)
<b>Blinking red slowly</b>	The battery pack cannot be replaced. (When the battery latch (C) is slid with the AC adaptor disconnected)
<b>Blinking red</b>	The built-in bridge battery has deteriorated. Contact Panasonic Technical Support.
<b>Not lit</b>	The battery pack can be replaced (While the AC adaptor connected, shutdown, hibernation)

## NOTE

- Once the battery is fully charged, the computer performs recharging only when the battery level becomes less than approximately 95%, so over-charging is avoided.
- When [LED] is set to [OFF] on the [Concealed Mode Configuration] menu, LED does not light.

## Charging



When connecting the computer to a power outlet, the battery charging starts automatically.

- The battery pack is not charged when you first purchase it. Be sure to charge it before using for the first time.

## Checking the Remaining Battery Power

### To check the remaining battery power on the screen

(After signing in to Windows)

- Touch  or  on the task tray.  
The remaining battery power is displayed.

### To check the remaining battery power using the battery indicator

(When the power is off or in sleep or hibernation)

- Disconnect the AC adaptor.

- Press the  button (A) and confirm the battery indicator (B).

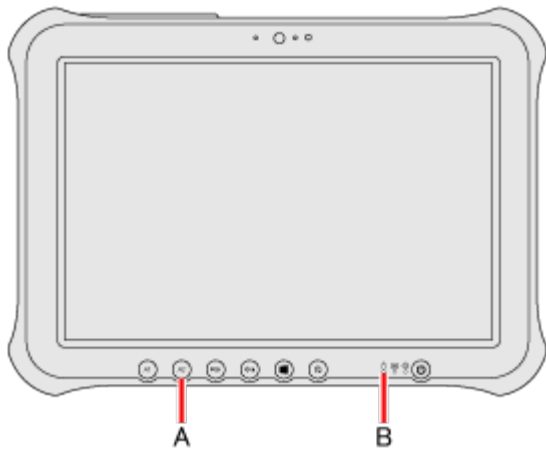

Battery indicator	Remaining battery power
Red	0 % - 4 %
Blinking orange	5 % - 19 %
Orange	20 % - 49 %
Blinking green	50 % - 94 %
Green	95 % - 100 %

## NOTE

- The battery display may not correspond to the actual remaining battery charge in the cases as below. To correct the display, perform the Battery Recalibration ( [Correcting the Battery Display \(Battery Recalibration\)](#) ).
  - The battery indicator remains red.
  - The indicator lights orange and the display shows 99% for a long time.
  - Low battery warning appears soon after a short time of use.  
This can occur when the computer is in sleep for a long time without power supply from the AC adaptor.
- The battery display may not be the same as that of notification area.  
This is not a malfunction.

## Computer behavior with low battery

The default settings are as follows.

When the battery level becomes 10 % [Low battery level]	When the battery level becomes 5 % [Critical battery level]
<ul style="list-style-type: none"> <li>• Displays a message that the battery level is low.</li> </ul> <p style="text-align: center;">↓</p>	<ul style="list-style-type: none"> <li>• The computer enters hibernation.</li> </ul> <p style="text-align: center;">↓</p>
<b>Charge the battery.</b>	<b>Connect the AC adaptor or replace the battery to start up the computer.</b>
<ul style="list-style-type: none"> <li>• Connect the AC adaptor immediately. If you do not have the AC adaptor, exit the running programs and Windows, then confirm that the power indicator is off.</li> <li>• If you have a fully charged spare battery, turn off the computer, replace the battery and turn the computer on again.</li> </ul>	<ul style="list-style-type: none"> <li>• Connect the AC adaptor and charge the battery.</li> <li>• If you have a fully charged spare battery, turn off the computer, replace the battery and turn the computer on again. When the computer enters hibernation with the battery down and you resume the operation without charging the battery, the Windows Resume Loader starts up. Follow the on-screen instructions. After that, however, Windows may not start up normally, or the [Low battery level]/[Critical battery level] function may not work normally.</li> </ul>



## NOTE

- **Battery goes to sleep if the battery level is about 5%, may be displayed such as “Not exist” or “Not use” is not a malfunction.**  
Please wait for a while to connect the AC adaptor.

## Correcting the Battery Display (Battery Recalibration)

The “Battery Recalibration” function measures and memorizes the battery capacity. To correct the battery display, use this function to fill the battery and then discharge it completely. Perform the procedure at least once immediately after purchasing the computer. Normally the interval of battery recalibration is 3 months.

The battery display may not be correct when the battery pack deteriorates after a long time use. In this case, perform the procedure again.

1. **Connect the AC adaptor.**

2. Touch  (Start) -  (Panasonic PC Settings Utility) -  (Support) -  (Battery) - [Perform battery recalibration].

3. **At the confirmation message, touch [OK].**

4. **Touch [OK].**

The computer restarts, and the “Battery Recalibration Utility” screen appears.

5. **Touch [OK].**

6. **Touch [Yes].**

The “Executing Battery Recalibration” screen appears, and start the battery recalibration.  
After the battery recalibration is finished, normal charging starts.

## NOTE

- To cancel the battery recalibration, press power switch 
- The temperature range should be 10°C to 30°C {50°F to 86°F}.
- Frequent recalibration of the battery can degrade the battery. A caution message appears when the battery recalibration is performed at the shorter interval than approximately a month. In this case, cancel the battery recalibration.
- If the computer is turned off during the battery recalibration (e.g., due to power failure, or accidental removal of the AC adaptor and battery pack), the battery recalibration will not be completed.
- The battery recalibration may take a long time due to the large battery capacity. This is not a malfunction. (An expected approximate recalibration time is displayed.)
- <Only for model with Built-in Bridge Battery>  
The battery recalibration cannot be performed for the built-in bridge battery.

## Replacing the Battery Pack

The battery pack is a consumable item so the replacement will be necessary. If the battery operation time becomes noticeably short and not recovered even after recalibrating the battery, replace with a new battery.

- The battery pack is not charged when you first purchase it. Be sure to charge it before using for the first time. Charging starts automatically when the AC adaptor is connected to the computer.
- Use only the specified battery pack with your computer.
- Make sure no foreign objects are under the computer.
- In sleep, do not remove/replace the battery pack. Otherwise your data will be lost and the computer may be damaged.
- If the computer is wet, wipe them off and open the cover. Make sure to dry off the computer, replace/remove the battery pack.

---

■ **<Only for model with Built-in Bridge Battery>**

When 5 minutes elapse after removing the battery pack in sleep, the sleep mode will be released.

---

**NOTE**

■ **<Only for model with Built-in Bridge Battery>**

If the built-in bridge battery has enough remaining power, you can replace the battery pack without turning off the computer (Hot swap) and during sleeping the computer (Warm swap).

---

1. **<Only for model without Built-in Bridge Battery>**

**Turn off the computer.**

Do not use the sleep function.

2. **Turn your computer over and remove/insert the battery pack.**

Make sure no foreign objects are under the computer.

● To remove

Push and slide the latch to the unlocked position, and raise the battery pack.

**<Only for model with Built-in Bridge Battery>**

Slide the latch (A) to the unlocked position and confirm that the battery indicator (B),

Confirm that the battery indicator on the rear of the computer lights green; this means that the built-in bridge battery has enough remaining power required for a hot swap.

When the battery indicator on the rear of the computer doesn't light; Shutdown, Hibernation and while the AC adaptor is connected to the computer.

- 
- In the case of a hot swap, finish replacing the battery within a minute. Depending on the built-in bridge battery status, the computer may enter hibernation within one minute. Replace the battery pack as soon as possible.
- Do not release your hand from the latch (A), while remain connected to the connector part (C).
- 

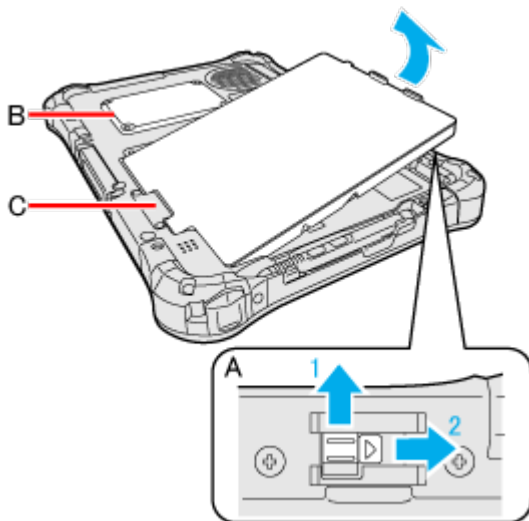

● To insert

Close the battery pack until it touch to the secured position.

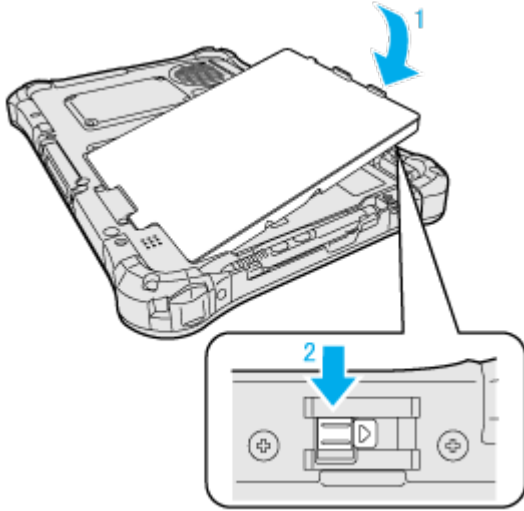

Be careful about the battery pack direction.

In case that the projection does not match the dents of the computer, detach the battery pack once, then slide it while pushing it lightly to avoid floating.

- 
- Make sure the latch is securely locked, otherwise the battery pack may fall when you carry the computer.
  - Do not remove the battery pack forcibly when the latches are locked. Doing so may damage the battery pack.
  - During battery replacement, the LCD backlight may become dark.

**<Only for model with Built-in Bridge Battery>**

- If the built-in bridge battery has not enough remaining power, you cannot replace the battery pack without turning off the computer.  
Turn off your computer before replacing the battery pack.
-



### Starting Up Your Computer Quickly

The sleep or hibernation functions allow you to shut off the computer without closing programs and documents. You can quickly return to the programs and documents that you were working on before sleep or hibernation.

Function	Data is saved to	Recovery time	Power supply
Sleep	Memory	Short	Required. (If power is not supplied, all data will be lost.)
Hibernation	Flash memory drive	Rather long	Not required. (However power is slightly consumed to keep the hibernation.)

### Setting Sleep or Hibernation

#### Sleep

1. Touch and hold  or  on the task tray, and then touch [Power Options].
2. Touch [Change plan settings] of the power plan you want to change.
3. Select the setting for "Put the computer to sleep", and then touch [Save changes].
  - The setting for hibernation may change unexpectedly when you change the setting for sleep. Confirm that the time to enter hibernation is 180 minutes (default setting) or longer (below).

#### Hibernation

1. After the step 2 of "Sleep" setting (above), touch [Change advanced power settings].
2. Double-touch [Sleep], and double-touch [Hibernate after].
3. Touch the item and select the setting.
4. Touch [OK].

### Precautions

- Connect the AC adaptor if the computer will be in sleep for a long period of time. If you cannot use the AC adaptor, use hibernation instead.
- Using sleep or hibernation repeatedly may cause malfunction of the computer. To stabilize computer operation, restart Windows regularly (about once a week) without using sleep or hibernation.
- Save the necessary data.
- Close files you have opened from removable disks and network drives.
- Do not enter sleep or hibernation in the conditions below, otherwise the data or file may be corrupted, sleep or hibernation may not work, or malfunction may occur in the computer or the peripheral devices.
  - When the extended desktop function is activated.
  - When the drive indicator  is on.
  - When playing/recording audio files or displaying motion video such as MPEG files.
  - When playing a DVD-Video.
  - When writing to a disc.
  - When using communication software or network functions.
  - When using peripheral devices.

If the computer fails to work normally, restart the computer.

- The password you set in the Setup Utility will be requested upon resuming from hibernation (but not from sleep) or fast startup, if [Password On Resume] is set to [Enabled] in the [Security] menu of the Setup Utility. To disable it, set [Password On Resume] to [Disabled].

The [Password On Resume] setting is valid when you shut down the computer by touching  (Start) -  (Power) - [Shut down].

- It may take 1 or 2 minutes to enter hibernation. Do not touch any button though the screen becomes dark.

The following problems will occur when you fail the password input (failing three times or leaving the computer unattended for one minute or more) while resuming from sleep or hibernation.

- **Failing the password input while resuming from hibernation:**  
<Only for model with LAN>
  - Cannot resume from hibernation by the Task Scheduler or the operation to open the display.

## Entering/Resuming from Sleep or Hibernation

The computer automatically enters sleep after:

- 20 minutes (when AC adaptor is connected) of inactivity
- 15 minutes (when operating on battery power) of inactivity

### To enter sleep or hibernation

In order to enter sleep or hibernation by following procedure, change the power option settings first so that the “Power and sleep button settings” operation is set to sleep or hibernation. (  [Setting Sleep or Hibernation](#) )

#### Using hardware functions

1. Press the power switch  (A).

Sleep: The power indicator (B) light blinks green.

Hibernation: The power indicator (B) light goes off.

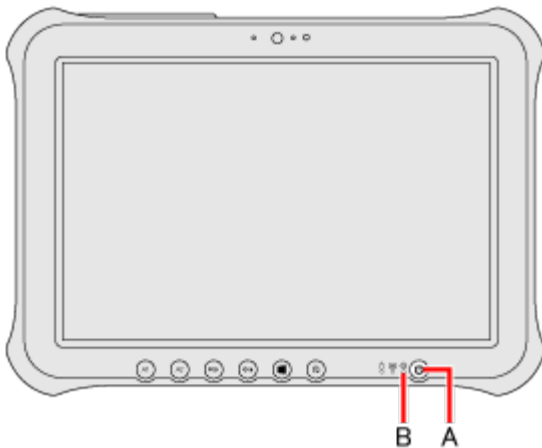

#### Alternative method



##### Using Windows function

You can alternatively enter sleep using Windows function.

1. Touch  (Start) -  (Power).
2. Touch [Sleep].

## NOTE

- Hibernation from the Windows system menu is not available as the factory default. To enter hibernation from the Windows system menu, the following setting is necessary.

1. Touch and hold  or  on the task tray, and then touch [Power Options].
2. Touch [Choose what the power button does] - [Change settings that are currently unavailable].
3. Add check mark for [Hibernate] and touch [Save changes].

### While the computer is entering sleep or hibernation

- Do not:
  - Use an external mouse or other peripheral devices.
  - Disconnect the AC adaptor.
  - Insert and remove the microSD Memory Card.

Wait until the power indicator blinks green (sleep) or goes off (hibernation).

- It may take 1 or 2 minutes to enter sleep or hibernation. Do not touch any button though the screen becomes dark.
- After releasing the power switch, do not operate it until the power indicator blinks or goes off.

If you press and hold the power switch  for longer than 4 seconds, the computer will forcibly shut down.

Unsaved data will be lost regardless of which option is selected under the "Control Panel" - [Hardware and Sound] - [Power Options] - [Choose what the power button does] - "When I press the power button".

### In sleep or hibernation

- Do not attach or remove peripheral devices. Doing so may cause malfunction.
- Power is consumed in sleep.

When power is exhausted, the data retained in memory will be lost. Connect the AC adaptor when the computer is in the sleep function for a prolonged time.

### To resume from sleep or hibernation

1. Press the power switch  (A).

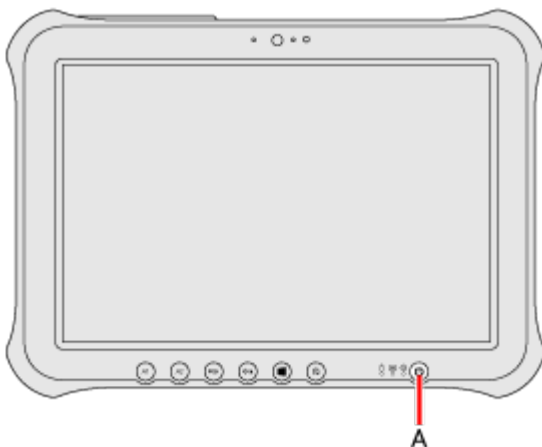

- Do not perform the following operations until resuming is complete. After the display is resumed, wait approximately 15 seconds (normally) or 60 seconds (when the computer is on a network).
  - Touch the screen or power switch.
  - Use an external mouse or other peripheral devices.

- 
- Connect or disconnect the AC adaptor.
  - Attach or remove the battery pack.
  - Shut down or restart Windows.
  - Enter sleep or hibernation.
- **If the computer enters the sleep mode while an external keyboard or mouse is connected, touching the external keyboard keys or mouse may resume the computer.**
-

# Panasonic PC Settings Utility

You can perform the following operations easily by using the Panasonic PC Settings Utility.

When starting up this application for the first time, connect to the Internet for initial setup. If it is first started up without Internet connection, the initial setup may take time, and several minutes may be required for startup.

## Starting Panasonic PC Settings Utility

1. Touch  (Start) -  (Panasonic PC Settings Utility).

The screen to the below appears.

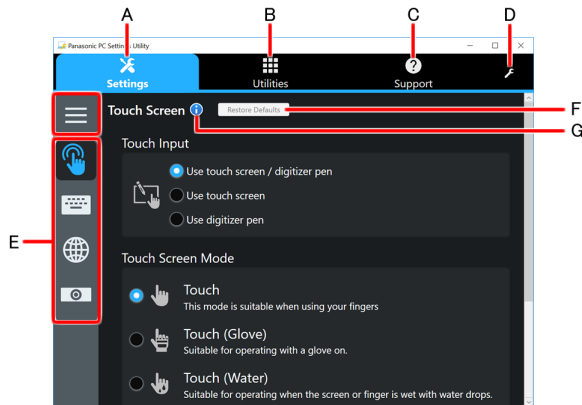

- A. Settings
- B. Utilities
- C. Support
- D. This Application Settings
- E. Menu  
Select the items.

When touching , name of the items appears.

- F. Restore Defaults  
Restore the settings to the default values.
- G. Information  
Display help.

### 2. Make the operation.



Settings



Touch Screen

Touch Screen:

- Touch Input

You can select the touch input mode.

- [Use touch screen/Use digitizer pen]  
When using your finger and digitizer pen (included).
- [Use touch screen]  
When using your finger.
- [Use digitizer pen]  
When using digitizer pen (included).

- Touch Screen Mode



You can select the suitable operation mode in Touch Screen Mode.

(  [Touch Screen Mode](#))

- [Touch]
- [Touch (Glove)]
- [Touch (Water)]

Touch Operation Support:

When you use a two-finger tap gesture to specify the area in which you want to perform touch operations, the area is displayed in a zoom window. To use this function, add a checkmark to [Support touch operation].

(  [About Touch Operation Support](#))



Button / Key

Tablet Buttons:



You can change the functions of ,  and  buttons.

(  [Setting the Tablet Buttons](#))



Network

Wireless LAN:

(  [Wireless LAN](#))



Camera

Camera Device:

- Front Camera
- Rear Camera

Enable or Disable the built-in camera. To switch the option, the administrator right is required.

If the camera is disabled by the Setup Utility, you cannot enable the camera by touching [Enabled].

(  [Camera](#))



Utilities

You can use Panasonic applications that display icons. To use these applications, touch an icon.



Support



Manual

[Launch Manual Selector]

For further information about the computer, you can refer to the on-screen manual.



- Update the on-screen manuals  
This describes the procedures to update the on-screen manual.
- Connect to a network  
This describes the connection procedures using the network devices mounted on this unit.
- Operating Instructions - Reference Manual (This Manual)  
This manual contains the practical information to help you fully enjoy the computer's performance. Update it to the latest version using network connection.
- Important Battery Tips  
The Important Battery Tips will provide you with the battery information so that you can use the battery in the optimum condition to obtain longer operation time.
- LIMITED USE LICENSE AGREEMENT



System



[Launch PC Information Viewer]

(  [Checking the Computer's Usage Status](#))

-  Battery  
 [Perform battery recalibration]  
 (  [Correcting the Battery Display \(Battery Recalibration\)](#) )

-  Notification Settings  
 Urgent Notice  
 [Settings]  
 Display the “Emergency notification setting” installation screen.

-  Troubleshooting  
 Fan control mode  
 Set the fan control mode.

-  Recovery Disc Creation  
 [Launch Recovery Disc Creation Utility]  
 (  [Create a Recovery Disc](#) )

 This Application Settings

- Themes Settings  
 Change the skin of this utility.
- Show/Hide each item  
 Touch [Administrator settings] to allow you to export or import the show/hide settings.  
 If “User Account Control” is displayed, touch [Yes].

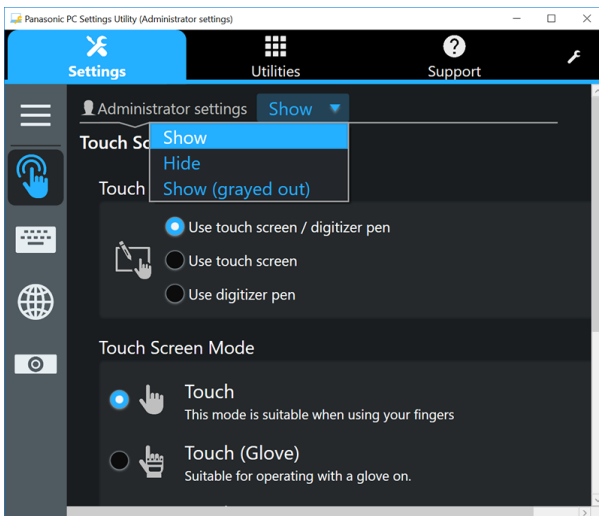

The new settings will be activated after restarting this application.  
 You can export or import the display items that can be used by XML files on this utility.

- About Panasonic PC Settings Utility:  
 Display the version information.

---

## To add or delete functions

---

To add or delete functions, follow the procedure below.

- Touch and hold  (Start) at the bottom left corner, and then touch [Apps and Features].
- Select [Panasonic PC Settings Utility], touch [Change].

3. Touch [Add or Remove Features], and then touch [Next].
4. Add or delete checkmarks, and then touch [Next].

## NOTE

---

- If “This program might not have uninstalled correctly” is displayed, follow the on-screen instructions.
-

<Only for model with LAN>

## Connecting LAN

- Do not connect the telephone cable to the LAN port.

1. **Turn off the computer.**

- Do not use sleep or hibernation.

2. **Connect the cable.**

- Open the cover (A) and connect the LAN port (B) and the network system (e.g., server, HUB) using a LAN cable.

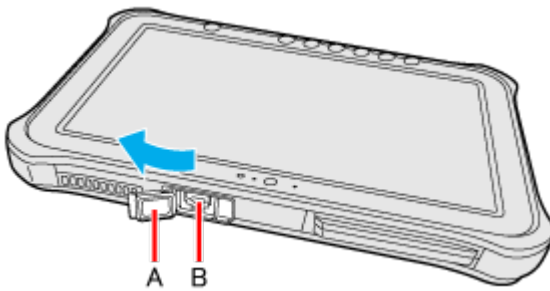

3. **Turn on the computer.**

## Disabling/Enabling Wireless Communication

<Only for model with wireless LAN, Bluetooth, wireless WAN, GPS on wireless WAN, and/or dedicated GPS>

There are several ways of disabling and enabling wireless communication.



- [Using airplane mode](#)
- [Turning wireless communication on/off quickly](#)
- [Using Network & Internet settings](#)
- Setting [\[Wireless Configuration\]](#) in the [\[Advanced\]](#) menu of the Setup Utility

### NOTE

- For further information about [Wireless LAN](#)

## Using airplane mode\*1

(For wireless LAN (Wi-Fi), Bluetooth, wireless WAN, and GPS on wireless WAN / dedicated GPS)

1. Touch  (Start) -  (Settings) - [\[Network & Internet\]](#) - [\[Airplane mode\]](#) . \*1
2. To disable wireless communications, set "Airplane mode"\*1 to [On].  
To enable wireless communications, set "Airplane mode"\*1 to [Off], and then;
  - set "Cellular" to [On] (for wireless WAN).
  - set "Wi-Fi"\*1 to [On] (for wireless LAN).
  - set "Bluetooth" to [On] (for Bluetooth).
  - set "GPS" to [On] (for GPS on wireless WAN).
  - set "GPS/GNSS" to [On] (for dedicated GPS).





\*1 : Screen messages are explained in [\[English \(United States\)\]](#).

(Depending on the language preference, some screen messages in these instructions are different from the actual screen messages. For example, [\[Flight mode\]](#)/[\[Wi-Fi\]](#) may be displayed instead of [\[Airplane mode\]](#)/[\[Wi-Fi\]](#) in some language preference.)



## Turning wireless communication on/off quickly



(For wireless LAN (Wi-Fi), Airplane mode)

### Turning on/off the Wi-Fi

1. Touch  on the task tray.
2. To turn off the Wi-Fi, touch  (Wi-Fi) . \*2  
The icon changes to , and then the icon  on the task tray changes to .  
To turn on the Wi-Fi, touch . Then the icon changes to .

## Turning on/off the airplane mode\*2

1. Touch  on the task tray.
2. To turn on the airplane mode, touch  (Airplane mode).

The icon changes to , and then the icon  on the task tray changes to .

To turn off the airplane mode, touch . Then the icon changes to .

\*2 : Screen messages are explained in [English (United States)].

(Depending on the language preference, some screen messages in these instructions are different from the actual screen messages. For example, [Flight mode]/[Wi-Fi] may be displayed instead of [Airplane mode]/[Wi-Fi] in some language preference.)

---

## Using Network & Internet settings

---

(For wireless LAN (Wi-Fi), wireless WAN, Bluetooth, and GPS on wireless WAN / dedicated GPS)

1. Touch  on the task tray.
2. Touch [Network & Internet settings].  
“Network & Internet” screen appears.
3. Touch the menu “Wi-Fi”<sup>\*3</sup>, “Cellular” or “Airplane mode”<sup>\*3</sup>, and turn on/off each wireless function.

\*3 : Screen messages are explained in [English (United States)].

(Depending on the language preference, some screen messages in these instructions are different from the actual screen messages. For example, [Flight mode]/[Wi-Fi] may be displayed instead of [Airplane mode]/[Wi-Fi] in some language preference.)

## Wireless LAN

<Only for model with wireless LAN>

- **Do not use wireless LAN on airplanes, in hospitals, or in other locations where wireless LAN signals may affect devices.**  
Follow the instructions of airline companies and hospitals. If you use the computer in these locations, turn off the wireless LAN.
- **To avoid unauthorized access to the computer through wireless LAN**  
We recommend you to make security settings such as encryption before using wireless LAN.  
Otherwise the disk data such as the shared files can be exposed to the risk of unauthorized access.

### NOTE

- Communication is established through the wireless LAN antenna (A). Do not block the antenna area with your hand or body.

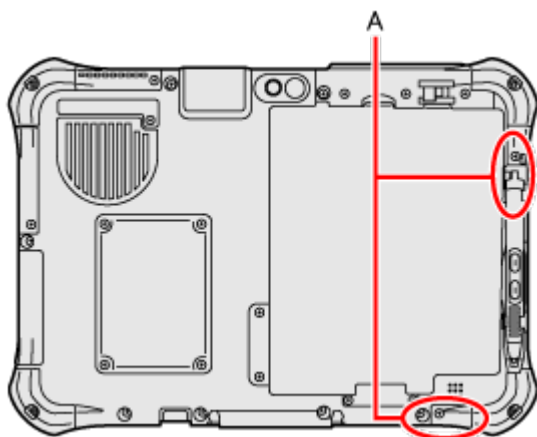

- The transmission rate will be lower when a microwave oven is used near by.
- To use wireless LAN, set [\[Wireless LAN\]](#) of [\[Wireless Configuration\]](#) to [\[Enabled\]](#) (default) in the [\[Advanced\]](#) menu of the Setup Utility.

## Using the Wireless LAN Function

Before using a wireless LAN, turn the wireless LAN communication on.

### Turning on/off the wireless LAN communication

1. To enable the wireless communication (  [Disabling/Enabling Wireless Communication](#)).

### Setting the wireless LAN access point

#### ■ Preparation

Follow the instruction manual of the wireless LAN access point to make settings for the access point to recognize the computer.

1. Turn the wireless LAN on.

2. Touch  or  on the task tray.

3. Select an access point, and touch [\[Connect\]](#).

4. Input the key you set for the access point to recognize the computer, and touch [\[Next\]](#).  
Wait for the computer to connect to the wireless LAN access point.

When the icon on the notification area is changed to , the wireless LAN setting is complete.

### NOTE

- 
- The settings depend on the network environment. For further information, ask the system administrator or the person in charge of the network.
  - If you use the stealth type wireless LAN access point which restricts automatic detection of the wireless LAN access point, take the following procedure.  
If you do not perform the procedure below, you may not be able to access the wireless LAN access point automatically or the wireless LAN access point may not be displayed.

1. Touch  on the task tray, and then touch [Hidden network].
2. Touch [Connect], enter the necessary information such as the network name (SSID), and touch [Next].

For further information, ask the system administrator or the person in charge of the network.

---

---

## Enabling/Disabling the Wireless LAN Standard IEEE802.11a (802.11a)

---

1. Touch  (Start) -  (Panasonic PC Settings Utility) -  (Settings) -  (Network).
2. Touch [Enabled] or [Disabled] for the wireless LAN IEEE802.11a.

### NOTE

- In some countries, communication using IEEE802.11a (5 GHz wireless LAN) standard is restricted by law.
  - If IEEE802.11a is enabled or disabled while the computer is connected to an IEEE802.11b/g access point, the connection will be temporarily interrupted.
-



## Bluetooth

<Only for model with Bluetooth>

You can access internet and other Bluetooth devices without connecting cables.

### NOTE

- Communication is established through the Bluetooth antenna (A). Do not block the antenna area with your hand or body.

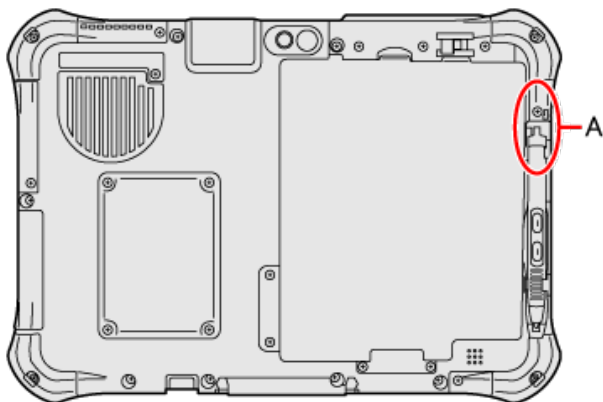

- To use Bluetooth, set [Bluetooth] of [Wireless Configuration] to [Enabled] (default) in the [Advanced] menu of the Setup Utility.
- The transmission rate will be lower when a microwave oven is used near by.

## Using the Bluetooth Function

Before using a Bluetooth, turn the Bluetooth communication on.

### Turning on/off the Bluetooth communication

- To enable the wireless communication (  [Disabling/Enabling Wireless Communication](#) ).

- Touch  (Start) -  (Settings) - [Network & Internet] - [Airplane mode] to [Off].

- To turn off the Bluetooth communications, set "Bluetooth" to [Off].  
To turn on the Bluetooth communications, set "Bluetooth" to [On].



\*1 : Screen messages are explained in [English (United States)].

(Depending on the language preference, some screen messages in these instructions are different from the actual screen messages. For example, [Flight mode] may be displayed instead of [Airplane mode] in some language preference.)

## To check the Bluetooth communication status

- Touch  (Start) -  (Settings) - [Devices] - [Bluetooth & other devices].

### NOTE

- You can also touching  on the task tray, and then touch  (Bluetooth Devices) - [Show Bluetooth Devices] to check the communication status.

<Only for model with wireless WAN>

### NOTE

- Communication is established through the Wireless WAN antenna (A). Do not block the antenna area with your hand or body.

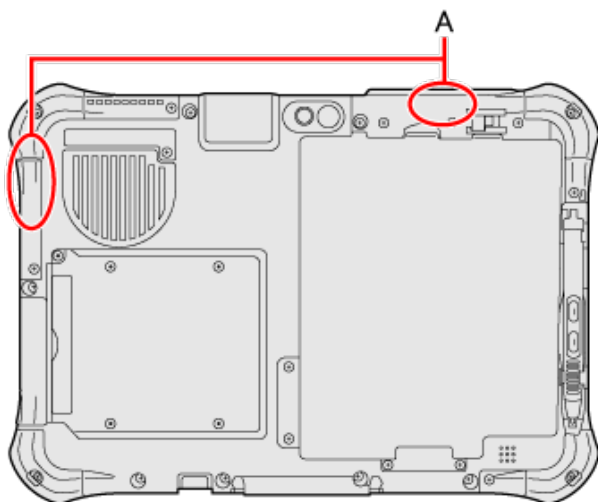

- To use wireless WAN, set [\[Wireless WAN\]](#) of [\[Wireless Configuration\]](#) to [\[Enabled\]](#) (default) in the [\[Advanced\]](#) menu of the Setup Utility.
- If “Device driver software was not installed correctly.” (or a similar message) appears when starting the computer or resuming from sleep or hibernation.
  - When communication works normally, Wireless WAN is operating correctly.
  - If communication fails, the device may not be recognized correctly. In this case, restart the computer.
- Do not use the nanoSIM card adapter.
- Do not insert nanoSIM cards on which labels or stickers are affixed. Failure to obey may result in malfunction.

## Inserting/Removing a nanoSIM Card

Before using the Wireless WAN, set a nanoSIM card to the nanoSIM card slot.

- Be sure to turn off the computer before inserting or removing the nanoSIM card.

### To insert a nanoSIM card

1. Turn off the computer and disconnect the AC adaptor.
2. Turn over the computer  
Make sure no foreign objects are under the computer.
3. Remove the battery pack (  [Replacing the Battery Pack](#) ).
4. <Only for model with Built-in Bridge Battery>  
Wait for about 3 minutes.

5. Remove the screws (A) and the nanoSIM card slot cover (B).

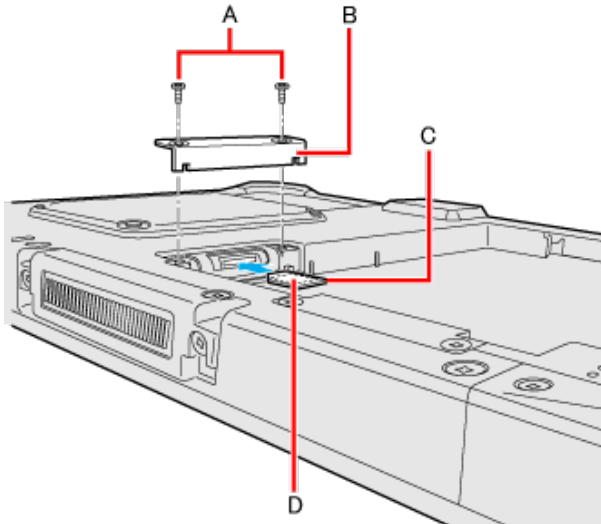

6. Insert the nanoSIM card (C) into the nanoSIM card slot with the contact side (D) facing downward and with the cut corner oriented as shown in the illustration.



- Do not insert the nanoSIM card upside down.

7. Close the nanoSIM card slot cover(B), attach it and tighten the screw (A) firmly.
  - If the cover is not closed, the nanoSIM card may jump out when the computer falls.
8. Insert the battery pack and connect the AC adaptor.

#### To remove a nanoSIM card

1. Turn off the computer and disconnect the AC adaptor.
2. Turn over the computer  
Make sure no foreign objects are under the computer.
3. Disconnect the AC adaptor, remove the battery pack.
4. <Only for model with Built-in Bridge Battery>  
Wait for about 3 minutes.
5. Remove the screws (E) and the nanoSIM card slot cover (F).

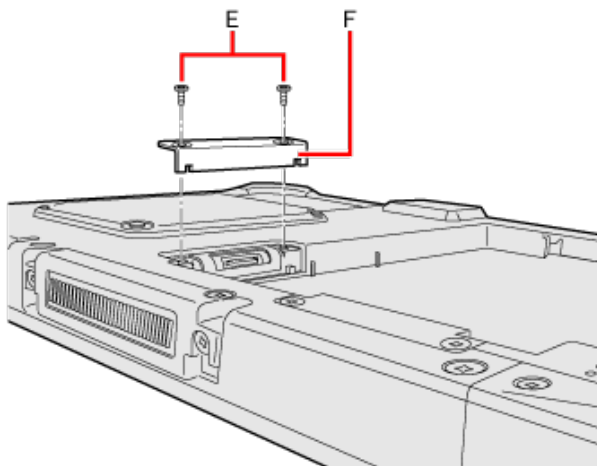

6. Push the card.  
It will come out of the slot a little bit.

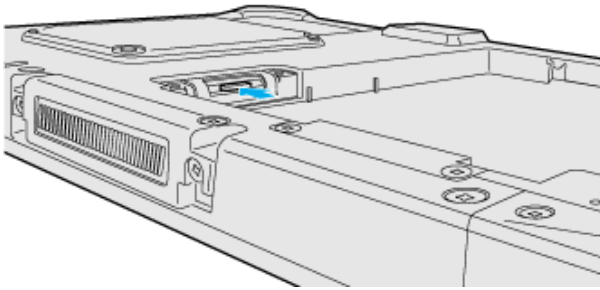

7. Pull the card all the way out.

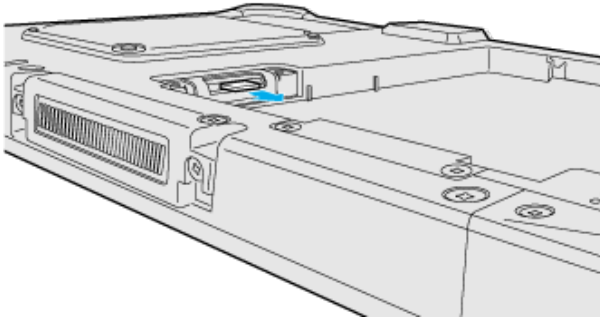

8. Close the nanoSIM card slot cover(F), attach it and tighten the screw (E) firmly.

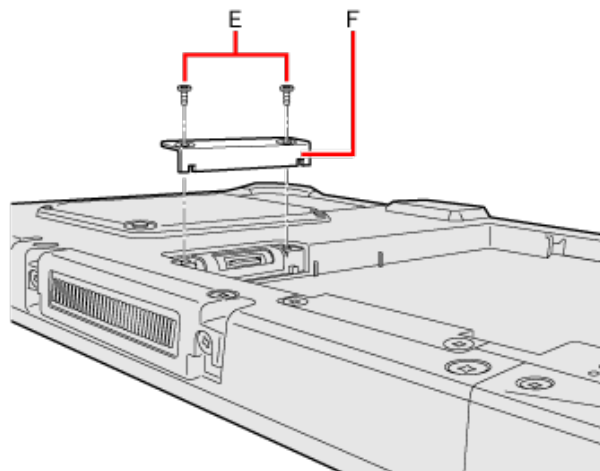

9. Insert the battery pack and connect the AC adaptor.

---

## Connect/Disconnect to a network

---

### Connecting to a network

If the APN setting is completed automatically after inserting the nanoSIM card, Internet connection will be possible. In such cases, the following settings are not necessary.

#### Adding an APN

If Internet connection via wireless WAN is not possible, perform the following to add an APN.

1. Touch  (Start) -  (Settings) - [Network & Internet].
2. Touch [Cellular].

3. Touch [Advanced options].

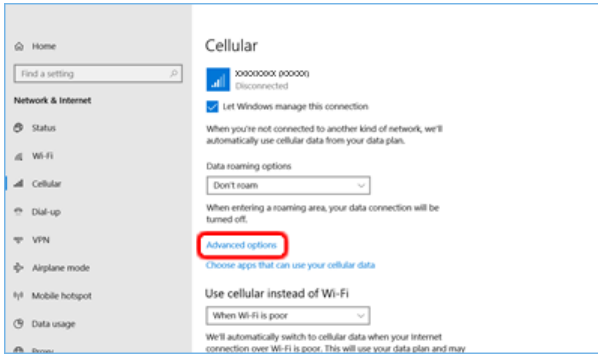

4. Touch [Add an APN].

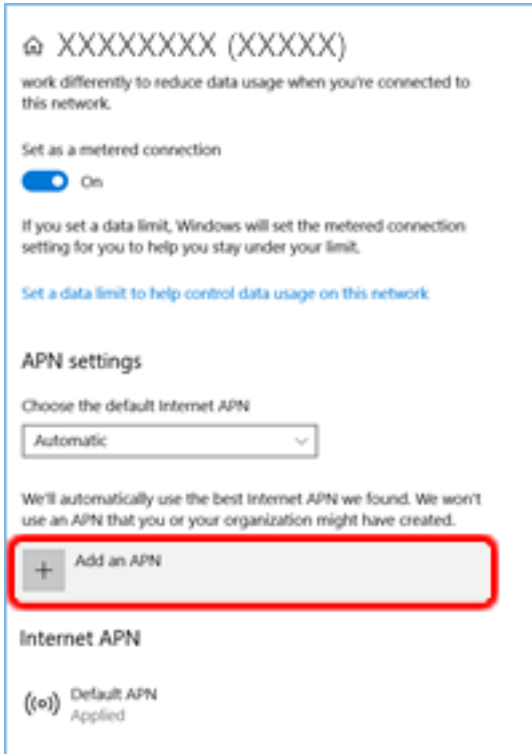

5. Input detailed information such as APN, and then touch [Save].





6. Touch [OK].

Internet connection will be possible.

7. If you are not connected to the Internet, select created APN profile, and then touch [Apply].

## NOTE



- When “Use cellular instead of Wi-Fi” is set to [When Wi-Fi is poor] (default), wireless WAN connections will be established only when there is no Internet connection via Wi-Fi.
- When using wireless WAN, perform the following to disable Airplane mode\*1.

1. Touch  (Start) -  (Settings) - [Network & Internet] - [Airplane mode] .
2. Set “Airplane mode”\*1 to [Off].
3. Set “Cellular” to [On].

\*1 : Screen messages are explained in [English (United States)].

(Depending on the language preference, some screen messages in these instructions are different from the actual screen messages. For example, [Flight mode] may be displayed instead of [Airplane mode] in some language preference.)

## Disconnecting to a network

1. Touch  (Start) -  (Settings) - [Network & Internet] - [Cellular].
2. Touch [Disconnect].

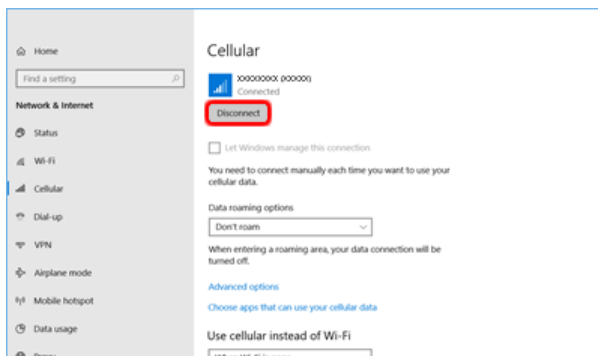

## NOTE

- You can also touch  on the task tray, and then touch [Disconnect].

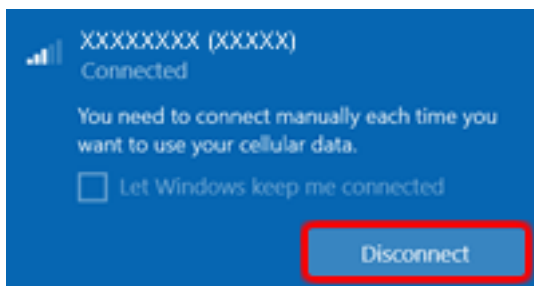

**<Only for model with dedicated GPS / GPS on wireless WAN>**

This computer has the GPS function with the wireless WAN module, and the dedicated GPS function.

For the differences, refer to the table below.

Devices	Device name	Support system
GPS on wireless WAN	EM7430/EM7455	GPS / GLONASS / BeiDou
	EM7305	GPS / GLONASS
Dedicated GPS	U-blox8 (M8N)	GPS / GLONASS / SBAS

GPS information can be checked using the “Panasonic PC GPS Viewer”.

To use the “Panasonic PC GPS Viewer”, proceed the following operation.

1. Touch  (Start) - [GPS Viewer].

You can start up “Panasonic PC GPS Viewer” from Panasonic PC Settings Utility. Launch Panasonic PC Settings Utility, and then touch 

(Utilities) -  (GPS Viewer).

## NOTE

- Communication is established through the GPS antenna (A). Do not block the antenna area with your hand or body.  
<Only for model with dedicated GPS>

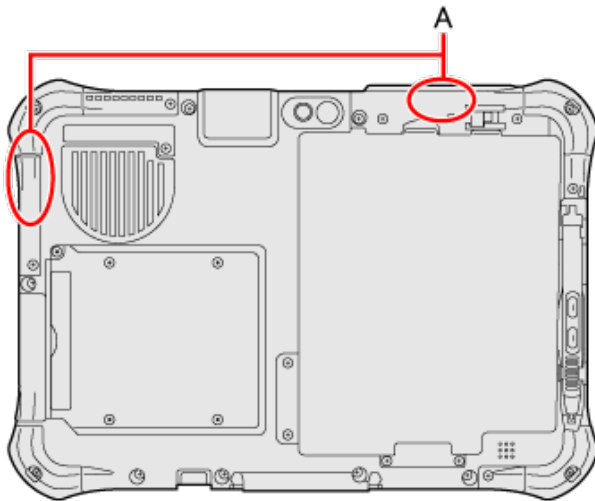

<Only for model with GPS on wireless WAN>

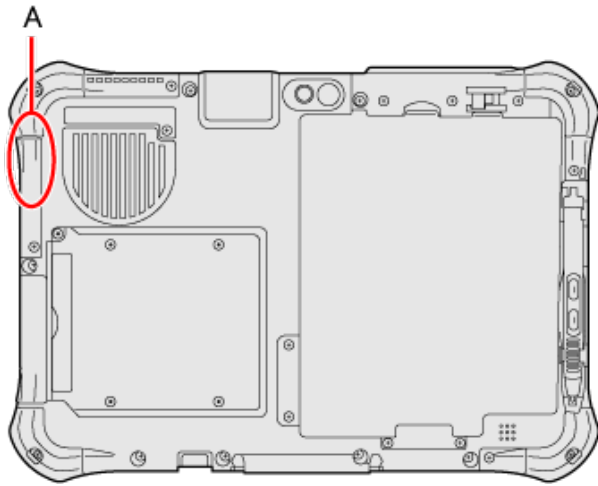

- When the u-blox Virtual COM Port is included in Ports (COM & LPT) under Device Manager, the following ports cannot be used.

For EM7430/EM7455:

Sierra Wireless Snapdragon™ X7 LTE-A NMEA Port

For EM7305:

Sierra Wireless NMEA Port

---





## Saving Power

You can extend battery life and save power also during battery pack usage.

### Reducing Power Consumption



Use the methods below to reduce power consumption.

- **Change the Power mode to “Best battery life”.**

1. Touch  or  on the task tray.
2. Move the “Power mode” slider (  ) to the left to set the “Power mode” to “Best battery life”.



- **Decrease the LCD brightness.**

Decrease the internal LCD brightness to reduce power consumption.

1. Touch  or  on the task tray.
2. Touch  to decrease the brightness.

- **Power management using the ambient light sensor.**

Automatically adjust the internal LCD brightness based on the ambient light.

1. Touch  (Start) -  (Settings) - [System] - [Display].
2. Touch the [Change brightness automatically when lighting changes] checkbox to select it.



Furthermore power saving options:

- **Turn off the computer when it is not in use**

You can also turn off only the wireless LAN or wireless WAN power.

- **Disconnect external devices (USB devices, external mouse, etc.) that are not being used**

- **Use Sleep**

Touch  (Start) -  (Power) - [Sleep] to set the computer to sleep when you have to leave the computer. This shuts down computer operation to reduce power consumption.

- **<Only for model with LAN>**

**Disable Wake Up from wired LAN function when it is not needed.**

This reduces power consumption in Sleep/Hibernation.

To confirm current settings:

1. Touch and hold  (Start) at the bottom left corner, and then touch [Device Manager].
2. Double-touch the Ethernet device (ex: Realtek USB FE Family Controller) under “Network adapters”, and then touch [Power Management].
3. Check the setting of [Allow this device to wake the computer].

- **When using the battery, do not use applications that place a significant load on the CPU.**

Some application software may place a large burden on the CPU only with start-up and may consume power.

- **When you are using the screen saver with 3D graphics, change to another screen saver**

To change the screen saver, touch and hold the desktop, touch [Personalize] - [Lock screen] - [Screen saver settings] and touch the title of the screen saver.



### Configuring Power Saving Settings

1. Touch  or  on the task tray,
2. Use the slider under “Power mode”, and select the setting.



## Customizing the Power Setting

You can choose the optimum power setting for your operating condition by selecting a power plan. You can also create your own power plan.



### Changing the Power Plan Setting

1. Touch and hold  or  on the task tray, and then touch [Power Options].
2. Touch [Change plan settings] of the power plan you want to change.
3. Change the settings.
  - [Change advanced power settings]: You can make more detailed settings.
4. Touch [Save changes].

### Creating Your Own Power Setting

1. Touch and hold  or  on the task tray, and then touch [Power Options].
2. Touch [Create a power plan], touch the basic plan and input the name of power plan.
3. Touch [Next].
4. Change the settings and touch [Create].
  - To change the settings or to make more detailed settings. (  [Changing the Power Plan Setting](#) )

### Deleting the Power Plan

1. Touch and hold  or  on the task tray, and then touch [Power Options].
2. Touch [Change plan settings] of the power plan you wish to delete.  
If the power plan you wish to delete is already selected, select another plan first.
3. Touch [Delete this plan], and then touch [OK] on the confirmation screen.

## Security Measures

Use these features to protect your data.

### Setting the Supervisor Password/User Password

Set the Supervisor Password before setting the User Password.

1. Start up the Setup Utility. (  [Starting the Setup Utility](#) )
2. Touch [Security] menu.
3. Double-touch [Set Supervisor Password] or [Set User Password].
4. Enter your password in [Create New Password] and touch « Enter » .
  - When the password has been set, you need to enter your password in [Enter Current Password] and touch « Enter » .
  - To disable the password, leave the input field empty and touch « Enter » .
5. Enter your password again in [Confirm New Password] and touch « Enter » .
6. Touch « F10 » , and then select [Yes] and touch « Enter » .  
When using the on-screen keyboard « F10 » key, touch [SYM] - [F10].

- Do not forget your password. If you forget your Supervisor Password, you will not be able to use your computer. Contact Panasonic Technical Support.
- When running the Setup Utility, do not leave and go away from your computer even for a short time, since other people may set or change the password.
- When running the Setup Utility, inputting from the keyboard and on-screen keyboard is based on the English keyboard layout. Pay attention of inputting if you use other keyboard layouts than English.



#### NOTE

- The password will not be displayed on the screen.
- You can use up to 32 alphanumeric characters (including spaces).
  - The case (upper/lower) is distinguished.
  - Use only the upper horizontal row of numeric keys to input your password.
  - You cannot use « Ctrl » to input a password.
- Disabling the Supervisor Password also disables the User Password.

### Setting the Windows Password

To set the password, proceed as follows.

The Windows password will be applied when you sign in to Windows, or resume the computer from the Lock screen.



1. Touch  (Start) -  (Settings) - [Accounts] - [Sign-in options].
2. Touch [Add] under "Password".

- Check the status of Num Lock and Caps Lock.

#### NOTE

- **Set the key entry mode to English (“ENG”) and enter characters.**

The keyboard layout can be added or changed in the following steps.

1. Touch  (Start) -  (Settings) - [Time & language] - [Region & language].
2. Touch a language and touch [Options].
3. Touch [Add a keyboard] and choose a keyboard from the list.

- **Remember your password. If you forget the password, you cannot use Windows. Creating a password reset disk beforehand is recommended.**

---

## Preventing Your Computer from Unauthorized Use

---

You can set a start-up password to protect your computer from unauthorized use.

1. **Set the password** (  [Setting the Supervisor Password/User Password](#)), and select [Enabled] in [Password On Boot] and/or [Password On Resume] in the [Security] menu of the Setup Utility.

### NOTE

- The [Password On Resume] of Setup Utility is effective when the computer was once shut down, and not effective when the computer resume from sleep.
- If the Supervisor Password or User Password has been set, the password input screen will be displayed on starting-up of the Setup Utility even though [Password On Boot] and/or [Password On Resume] is set to [Disabled]. If you set [Password On Boot] to [Enabled] and set [Password On Reboot] to [Same as Boot], password input will also be required at Windows restart. ([Same as Boot] is the default setting.)

---

## Preventing Your Flash Memory Drive from Being Read or Written

---

The flash memory lock function protects the flash memory data from being read or written by removing the flash memory from the computer. (Note that the flash memory lock does not guarantee complete protection of the data.)

1. Select [Enabled] in [[Hard Disk Lock](#)] in the [Security] menu of the Setup Utility.

- **You cannot use the flash memory lock function without setting the Supervisor Password. Set the Supervisor Password beforehand** (  [Setting the Supervisor Password/User Password](#)).
- **When you have your flash memory drive repaired.**
  - Contact Panasonic Technical Support.
  - Before sending back the flash memory drive, be sure to set the [Hard Disk Lock] to [Disabled].

### NOTE

- The flash memory lock function works with the built-in flash memory. It does not work with the external hard disk.
- We recommend you to set [Password On Boot] to [Enabled] to ensure security though it is not required to enable the flash memory lock.
- Note that the flash memory lock does not guarantee complete protection of the data.

---

## Disabling USB Devices

---

Disable USB flash Memory operation to prevent the drive from being read/written and from being used to start the computer.

You can protect your data from unauthorized access or accidental overwriting.

1. Select [Disabled] in [[Cradle USB Port](#)]/[[Legacy USB Support](#)] in the [Advanced] menu of the Setup Utility.

<Only for model that supports TPM>

---

## Device encryption

---

Using device encryption can protect folders or files from illegal accesses in the case the computer is lost or stolen. This computer supports the "Device encryption" function. This function is set to on as factory default, however, the encryption is not completed yet. To complete the encryption, you need to sign in with your "Microsoft account". Follow the instruction of the system administrator to complete the setting.

### NOTE

- **When you execute [Create a system image] while signed into your Microsoft account with "Device encryption" enabled, the "You have chosen to back up drive c: which is encrypted. The backup location will not be encrypted. Make sure the backup is kept in a physically secure location." warning message may appear.**

When attempting to recover a backup created under the above conditions, the "System Image Recovery" screen will appear and entry of the recovery key will be required. In such cases, use the recovery key that you previously printed or saved to a file, or perform the following to acquire the recovery key.

1. Access the "<http://go.microsoft.com/fwlink/p/?LinkId=237614>" URL on a device connected to the Internet (e.g., another computer or tablet), and sign into your Microsoft account.

If multiple recovery keys are displayed, acquire the recovery key for the key ID that appears on the "System Image Recovery" screen.

- **Backups created with [Create a system image] are not encrypted. Physically store the media on which the backup is stored in a safe location.**
  - **The backup recovery procedure will complete when you connect to the Internet, and a new recovery key will be created at that point.**
  - **Additionally, entry of the recovery key will be required when restoring restore points or during startup in safe mode, for example. In such cases, perform the above procedure to acquire the recovery key.**
- 

---

## Other security measure

---

- **About Secure Boot**

"Secure Boot" is a function that protects your computer by prohibiting Operating System other than those permitted under factory default conditions from being executed during startup.

When performing [Clear Secure Boot Keys] to use Secure Boot.

<When using the function of Microsoft\_DeviceGuard/CredentialGuard>\*1

- Select [Install default Secure Boot keys (Device Guard Ready)].

<When not using the function of Microsoft\_DeviceGuard/CredentialGuard>

- Select [Install default Secure Boot keys].

For further information, ask the system administrator.

\*1 : It is not supported by the factory OS.

- **About TPM**



<Only for model that supports TPM>

TPM (Trusted Platform Module) is a security chip aimed at high level cryptographic processing and secure storage of encryption keys.

In the file encryption using the TPM, encryption keys can be stored on a TPM chip separated from the internal disk. This will allow you to increase the security level.

To use the TPM function, perform the following steps.

For more information about the usage, follow the instructions by a system administrator.



1. Touch  (Start) -  (Settings) - [Update & Security] - [Device encryption] - [BitLocker settings].
2. Touch [TPM Administration].

- **Windows Hello**

This function is used to sign in to Windows quickly, or perform individual authentication.

<Only for model with camera with IR sensor>

The face recognition for Windows Hellos is supported. To use Windows Hellos, perform the following steps for setup.

1. Touch  (Start) -  (Settings).
2. Touch [Accounts] - [Sign-in options].
3. Touch [Set up] under the “Windows Hello”.
4. Follow the on-screen instructions.

## NOTE

---

- To use Windows Hellos, you need to set the password and PIN for sign-in options.
  - During face recognition, the IR sensor camera light turns on, and becomes hot. Do not touch the IR sensor section when the light is on, and shortly after the light turns off.
-

## Display Rotation

The built-in acceleration sensor detects the computer's inclination, and the screen display rotates automatically. Definition of rotation angles are shown below.

Primary Landscape



Secondary Landscape



Primary Portrait



Secondary Portrait

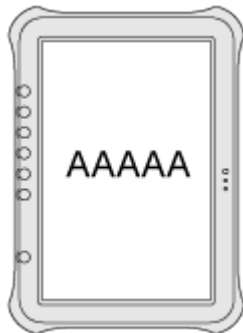

## Rotation Lock

The Rotation Lock button allows you to lock the screen display.

1. Press the Rotation Lock button  (A).

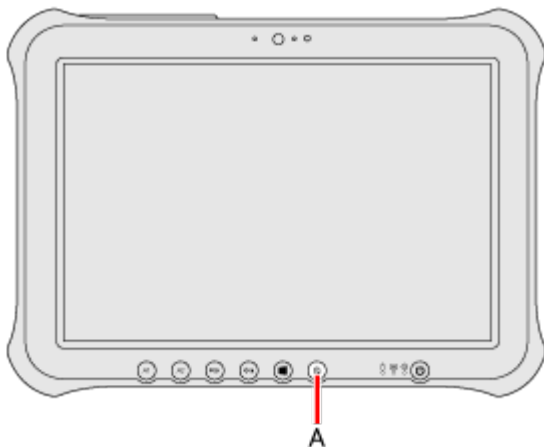

You can switch automatic rotation ON/OFF by pressing the Rotation Lock button .

Alternatively you can switch automatic rotation ON/OFF by the following procedure:

1. Touch  (Notification) on the task tray, and then touch  (Rotation lock) or  (Rotation lock).

## NOTE

- 
- When an external display is connected to the computer and the computer is rotated while in the “Duplicate” mode or “Extend” mode:  
The screen display on the external display does not rotate.  
The screen display on the internal LCD remains landscape, and does not rotate.
  - To change the angle of the screen rotation manually, perform the following steps.

Touch  (Start) -  (Settings) - [System] - [Display].

- While the display is rotated:
    - Do not use the Extended Desktop. The digitizer may not work properly.
    - Do not set the resolution larger than that of the internal LCD.
    - The computer's performance is slightly lowered.
  - While the display is set to rotate automatically, the computer's performance is slightly lowered.
  - When the display is rotated, the motion video may not be displayed correctly or the sound may be distorted. Return the display angle to primary landscape.
  - When you start up Windows and rotate the display right after signing in, the display may return to the previous state. Then, the display returns to the rotated state. The similar situation will occur when you switch the user, computer resumes from Sleep-/Hibernation and Windows is unlocked.
-



## Concealed Mode

You can make your computer inconspicuously using the Concealed Mode.

You can select on/off of LCD backlight, LED, Sound, Wireless Radio, Fan, Camera light<sup>\*1</sup>, Camera Flash<sup>\*1</sup> and Barcode Reader light<sup>\*2</sup>.

\*1 : Only for model with Rear Camera.

\*2 : Only for model with Barcode Reader.

- Concealed Mode is disabled as the factory default.
- The camera indicator cannot be turned off.

## Switching the Concealed Mode

<Only when [Concealed Mode] is set to [Enabled]>

1. Press  .

### NOTE

- If you press  in succession, the Concealed Mode may not be switched. More than 4 seconds interval is necessary to switch on/off.

## Disabling/Enabling the Concealed Mode

This function is effective when the computer is restarted.

1. Set [Concealed Mode] of [Concealed Mode Configuration] to [Enabled] or [Disabled] in the [Main] menu of the Setup Utility.

## Change the settings

This function is effective when the computer is restarted.

1. You can change the devices turned on/off in [Concealed Mode Configuration] with Setup Utility. When Concealed Mode is enabled, the

 button will be assigned as the Concealed Mode trigger key.



### NOTE

- When set [LCD Backlight] to [Minimum] and [LED] to [ON], the LED may become dark.
- When [LCD Backlight] is set to [OFF], touch operation is disabled.

## Setup Utility

You can make the settings of the computer's operating environment (password settings, startup drive selection, etc.)

### Starting the Setup Utility

1. Touch  (Start) -  (Settings) - [Update & Security] - [Recovery].
2. Touch [Restart now] under "Advanced startup"\*1.  
\*1 : Screen messages are explained in [English (United States)].  
(Depending on the language preference, some screen messages in these instructions are different from the actual screen messages. For example, [Advanced start-up] may be displayed instead of [Advanced startup] in some language preference.)
3. Touch [Troubleshoot] - [Advanced options] - [UEFI Firmware Settings] - [Restart].  
The computer restarts, and the Setup Utility screen appears.

When [Enter Password] is displayed, enter your password.

#### When you start the Setup Utility with Supervisor Password

- You can make the settings of all items of the Setup Utility.

#### When you start the Setup Utility with User Password

- Note the following:
  - In the [Advanced] and [Boot] menus, you cannot make the settings of all items.
  - In the [Security] menu, you can change only the User Password when [User Password Protection] is set to [No Protection]. You cannot delete the User Password.
  - In the [Exit] menu, you cannot make the setting of [Load Default Values] and [Boot Override].
  - << F9 >> (Setup Defaults) does not function.

To set Setup Utility, alternatively you can use touch input and pen input.

#### Using touch screen:

Double-touch the setting value to be changed, select the new value, and touch it again.

#### Using on-screen keyboard:



To input characters and symbols, touch  at the upper right corner of the Setup Utility screen to display the on-screen keyboard.



ESC	1	2	3	4	5	6	7	8	9	0	BKS
q	w	e	r	t	y	u	i	o	p	ENTER	
a	s	d	f	g	h	j	k	l	↑	SPACE	
z	x	c	v	b	n	m	CAP	←	↓	→	SYM

To operate special keys such as a function key, touch [SYM] on the on-screen keyboard so that the key is highlighted as illustrated below.

F1	F2	F3	F4	F5	F6	F7	F8	F9	F10	F11	F12
`	-	=	~	!	@	#	\$	%	^	ENTER	
&	*	(	)	_	+	[	]	\	{	}	SPC
	:	'	:	"	,	.	/	<	>	?	SYM

#### Using tablet buttons:

The tablet buttons operates at follows.

-  : Move to the item below
-  : Move to the item right



• : Enter (select)



• : Move to the [Exit] menu.

## NOTE

- Setup Utility screen is displayed on the internal LCD even when an external display is connected to the computer as the factory default.

## Information Menu

Underlined items are the factory presets.

Language	<u>English</u> French Japanese
----------	--------------------------------------

### Product Information

Model No. Serial No.	Computer information (cannot be changed.)
-------------------------	---

### System Information

Processor Type Processor Speed Memory Size Available Memory Hard Disk	Computer information (cannot be changed.)
---	---

### BIOS Information

BIOS BIOS Configuration Embedded Controller Intel(R) ME Firmware Accumulative Operating Time Access Level	Computer information (cannot be changed.)
--	---

## Main Menu

Underlined items are the factory presets.

System Date <ul style="list-style-type: none"> <li>• Day of the Week, Month/Day/Year.</li> <li>• You can touch Month/Day/Year to move the cursor.</li> </ul>	[ <u>xxx xx/xx/xxxx</u> ]
System Time <ul style="list-style-type: none"> <li>• 24-hr. style.</li> <li>• You can touch Hours/Minutes/Seconds to move the cursor.</li> </ul>	[ <u>xx:xx:xx</u> ]

▶ Tablet Button Configuration	Enter the sub-menu.
-------------------------------	---------------------

Sub-menu displayed when "Tablet Buttons Configuration" is selected

A1 Button*2	Disabled <u>Application1</u> Ctrl+Alt+Del Concealed Mode Trigger
Preboot Key Binding <ul style="list-style-type: none"> <li>• Key assignment during startup.</li> </ul>	Not Assigned F1 F2 F3 F4 F5 F6 F7 F8 F9 F10 F11 <u>F12</u>
A2 Button	Disabled <u>Application2</u> (Only for model without Barcode Reader) Ctrl+Alt+Del Wireless Switch <u>Barcode Reader Trigger</u> (Only for model with Barcode Reader)
Preboot Key Binding <ul style="list-style-type: none"> <li>• Key assignment during startup.</li> </ul>	Not Assigned F1 <u>F2</u> F3 F4 F5 F6 F7 F8 F9 F10 F11 F12
Up/Down Buttons	Disabled <u>Volume Up/Down</u> Brightness Up/Down
Windows Button	Disabled <u>Enabled</u>
Rotation Lock Button	Disabled Application3 Ctrl+Alt+Del Barcode Reader Trigger <u>Rotation Lock</u>

Preboot Key Binding <ul style="list-style-type: none"> <li>Key assignment during startup.</li> </ul>	Not Assigned F1 F2 F3 F4 F5 F6 F7 F8 F9 F10 F11 <u>F12</u> Esc
--	---

\*2 : When [Concealed Mode] is set to [Enabled], it becomes Concealed Mode Trigger.

#### Table of Preboot Key Bindings

A1 Button	Display the currently assigned button.
A2 Button	Display the currently assigned button.
Down Button	Display the currently assigned button.
Up Button	Display the currently assigned button.
Windows Button	Display the currently assigned button.
Rotation Lock Button	Display the currently assigned button.

LCD Brightness Mode	<u>Normal Brightness</u> Low Brightness
Battery Charging Indicator	<u>On Continuous</u> Flashing
Power On AC	<u>Disabled</u> Enabled

Concealed Mode Configuration <ul style="list-style-type: none"> <li>The sub-menu appears when this item is selected.</li> </ul>	Enter the sub-menu.
---	---------------------

#### Sub-menu (Concealed Mode Configuration)

Concealed Mode	<u>Disabled</u> Enabled
LCD Backlight* <sup>3</sup> <ul style="list-style-type: none"> <li>When [LCD Backlight] is set to [OFF], touch operation is disabled.</li> </ul>	OFF Minimum <u>ON</u>
LED* <sup>3</sup> <ul style="list-style-type: none"> <li>Except for the camera indicator and the LED of external devices.</li> </ul>	OFF <u>ON</u>
Sound* <sup>3</sup>	OFF <u>ON</u>
Wireless Radio* <sup>3</sup>	OFF <u>ON</u>

Camera Light <sup>*3</sup>	OFF <u>ON</u>
Fan <sup>*3</sup>	OFF <u>ON</u>
<Only for model with Barcode Reader> Barcode Reader <sup>*3</sup>	OFF <u>ON</u>

\*3 : Can only be configured when [Concealed Mode Configuration] is set to Enabled.

▶ Fan Diagnostics	Enter the sub-menu.
Start Fan Test	Start fan test.
▶ Optional Kit Configuration <ul style="list-style-type: none"> <li>Normally do not change this setting.</li> </ul>	Enter the sub-menu. A separately provided password is required to enter the sub-menu.

## Advanced Menu

Underlined items are the factory presets.

▶ CPU Configuration <ul style="list-style-type: none"> <li>The sub-menu appears when this item is selected.</li> </ul>	Enter the sub-menu.
--	---------------------

### ■ Sub-menu (CPU Configuration)

Intel(R) Hyper-Threading Technology	Disabled <sup>*4</sup> <u>Enabled</u>
-------------------------------------	--

\*4 : The following settings can be made when [Disabled] for "Intel(R) Hyper-Threading Technology" is selected.

Intel(R) Virtualization Technology <ul style="list-style-type: none"> <li>Can be changed only when [Intel(R) VT-d] is set to [Disabled].</li> </ul>	Disabled <u>Enabled</u>
Intel(R) VT-d	Disabled <u>Enabled</u>
Intel(R) Trusted Execution Technology <ul style="list-style-type: none"> <li>Can be changed only when [Intel(R) VT-d] is set to [Enabled].</li> </ul>	<u>Disabled</u> Enabled
Intel(R) Turbo Boost Technology 2.0	Disabled <u>Enabled</u>
Intel(R) Software Guard Extensions	<u>Software Controlled</u> Enabled Disabled
Processor Reserved Memory	<u>Disabled</u> 32MB 64MB 128MB

## Peripheral Configuration

<p>▶ Serial Port Settings</p> <ul style="list-style-type: none"> <li>The submenu appears when this item is selected.</li> <li>Used to configure the Barcode Reader.</li> </ul>	Enter the sub-menu
--	--------------------

### Sub-menu (Serial Port Settings)

<p>Serial Port</p> <ul style="list-style-type: none"> <li>Only for model with Serial Port.</li> </ul>	Disabled Enabled <u>Auto</u>
<p>I/O IRQ</p> <ul style="list-style-type: none"> <li>Can be changed only when [Serial Port] is set to [Enabled].</li> </ul>	<u>3F8/IRQ4</u> <u>2F8/IRQ3</u>
<p>Barcode Reader</p> <ul style="list-style-type: none"> <li>Only for model with Barcode Reader.</li> </ul>	Disabled Enabled <u>Auto</u>
<p>I/O IRQ</p> <ul style="list-style-type: none"> <li>Can be changed only when [Serial Port] is set to [Enabled].</li> </ul>	<u>3F8/IRQ4</u> <u>2F8/IRQ3</u>

<p>▶ Wireless Configuration</p> <ul style="list-style-type: none"> <li>The sub-menu appears when this item is selected.</li> </ul>	Enter the sub-menu.
--	---------------------

<p>LAN</p> <ul style="list-style-type: none"> <li>Only for model with LAN</li> </ul>	Disabled <u>Enabled</u>
<p>Power On by LAN</p> <ul style="list-style-type: none"> <li>Can be changed only when LAN is set to [Enabled].</li> </ul>	Disabled <u>Enabled</u>

### Sub-menu (Wireless Configuration)

<p>Wireless LAN</p> <ul style="list-style-type: none"> <li>Only for model with wireless LAN</li> </ul>	Disabled <u>Enabled</u>
<p>Wireless WAN</p> <ul style="list-style-type: none"> <li>Only for model with wireless WAN</li> </ul>	Disabled <u>Enabled</u>
<p>Bluetooth</p> <ul style="list-style-type: none"> <li>Only for model with Bluetooth</li> </ul>	Disabled <u>Enabled</u>
<p>GPS</p> <ul style="list-style-type: none"> <li>Only for model with dedicated GPS</li> </ul>	Disabled <u>Enabled</u>

<p>microSD Slot</p>	Disabled <u>Enabled</u>
<p>Extension Port</p>	Disabled <u>Enabled</u>

<p>Smart Card</p> <ul style="list-style-type: none"> <li>Only for model with Smart Card slot</li> </ul>	Disabled <u>Enabled</u>
---	----------------------------

Contactless Smart Card Reader <ul style="list-style-type: none"> <li>Only for model with Contactless Smart Card Reader</li> </ul>	Disabled <u>Enabled</u>
UHF-RFID <ul style="list-style-type: none"> <li>Only for model with UHF-RFID</li> </ul>	Disabled <u>Enabled</u>
Magnetic Stripe Card Reader <ul style="list-style-type: none"> <li>Only for model with Magnetic Stripe Card Reader</li> </ul>	Disabled <u>Enabled</u>

USB Port	Disabled <u>Enabled</u>
SuperSpeed USB	Disabled <u>Enabled</u>
Cradle USB Port	Disabled <u>Enabled</u>
SuperSpeed USB	Disabled <u>Enabled</u>
Legacy USB Support	Disabled <u>Enabled</u>

#### Camera Configuration

Camera (Front)	Disabled <u>Enabled</u>
Camera (Rear)	Disabled <u>Enabled</u>
Thermal Camera <ul style="list-style-type: none"> <li>Only for model with Thermography Camera</li> </ul>	Disabled <u>Enabled</u>

## Boot Menu

Underlined items are the factory presets.

Boot Mode <ul style="list-style-type: none"> <li>If the startup from USB devices is not possible, set [Compatible] and retry. However, setting [Compatible] will require longer time to display the Windows boot screen than setting [Normal].</li> </ul>	<u>Normal</u> Compatible
--	-----------------------------

<ul style="list-style-type: none"> <li>UEFI Priorities</li> <li>The sub-menu appears when this item is selected.</li> </ul>	Enter the sub-menu.
---	---------------------

#### UEFI Priorities

Boot Option #1	<u>Windows Boot Manager</u> Windows Recovery Environment Recovery Partition Disabled
----------------	---



Boot Option #2	Windows Boot Manager <u>Windows Recovery Environment</u> Recovery Partition Disabled
Boot Option #3	Windows Boot Manager Windows Recovery Environment <u>Recovery Partition</u> Disabled

### UEFI Boot Device Control

Set whether to enable or disable the startup of each device.

UEFI Boot from Hard Disk	Disabled <u>Enabled</u>
UEFI Boot from LAN	Disabled <u>Enabled</u>
UEFI Boot from USB	Disabled <u>Enabled</u>

### To change the boot order

- Boot from a device or not can be selected at [UEFI Priorities], device by device.



- You can select the boot device during start-up of the computer, too. Press  (Rotation Lock) soon after “Panasonic” boot screen is displayed. [Boot Menu] appears and you can select the device. To use this function, set [Boot Popup Menu] to [Enabled].

## Security Menu

Underlined items are the factory presets.

### Boot Prompt Configuration

Boot Popup Menu	<u>Disabled</u> Enabled
Password On Boot <ul style="list-style-type: none"> <li>• The shutdown when the fast startup is enabled, this function is ineffective.</li> </ul>	Disabled <u>Enabled</u>
Password On Reboot	Disabled <u>Same as Boot</u>
Password On Resume <ul style="list-style-type: none"> <li>• Can be changed only when [Password On Boot] is set to [Enabled].</li> <li>• This function is effective when the computer is restarted after a shutdown (when fast startup is enabled) and when the computer resumes from hibernation, but not when it resumes from sleep.</li> </ul>	Disabled <u>Enabled</u>

Set Supervisor Password	Enter the sub-menu.
Hard Disk Lock <ul style="list-style-type: none"> <li>• Can be changed only when [Set Supervisor Password] is set.</li> </ul>	<u>Disabled</u> Enabled
User Password Protection	<u>No Protection</u> Protected

Set User Password <ul style="list-style-type: none"> <li>Can be changed only when [Set Supervisor Password] is set.</li> </ul>	Enter the sub-menu.
SW KB Support for Encryption	<u>Disabled</u> Enabled
SW KB Support for BitLocker	<u>Disabled</u> Enabled

<p>▶ Embedded Security (TPM)</p> <ul style="list-style-type: none"> <li>Only for model that supports TPM.</li> <li>Can be changed only when [Set Supervisor Password] is set.</li> <li>Sub-menu items: <ul style="list-style-type: none"> <li>Sub-Menu Protection</li> <li>TPM State (Depending on the models, this item is not displayed.)</li> <li>Pending TPM operation When [Clear TPM Owner] is selected, clear owner information in the TPM chip. Use for discarding and transferring this product. If you select [Clear TPM Owner] when the BitLocker is effective, you may need to reinstall OS.</li> <li>Current TPM Status Information (Depending on the models, this item is not displayed.)</li> </ul> </li> </ul>	Enter the sub-menu.
<p>▶ AMT Configuration</p> <ul style="list-style-type: none"> <li>Only for model that supports Intel(R) AMT.</li> <li>Can be changed only when [Set Supervisor Password] is set.</li> </ul>	Enter the sub-menu.
<p>▶ Secure Boot</p> <ul style="list-style-type: none"> <li>The sub-menu appears when this item is selected.</li> <li>If you change factory default setting, preinstalled-OS may not operate correctly.</li> </ul>	Enter the sub-menu.

---

## Exit Menu

---

Save Values and Reboot	To reboot the system after saving the changes.
Reboot Without Saving Changes	To reboot the system without saving the changes.

### ■ Save Options

Save Current Values	To save the changes for all Setup options.
Load Previous Values	To load previous values for all Setup options.

Load Default Values	To return the settings to the default values.
---------------------	---

### ■ Boot Override

Windows Boot Manager	Boot from preinstalled OS.
Recovery Partition	Erase your flash memory or restore the computer to its original factory default image.
Windows Recovery Environment	Boot from Windows Recovery Environment.

Depending on the hardware constructions, some device names are different.



### Operation environment

- Place the computer on a flat stable surface not subject to shock, vibration, and danger of dropping. Do not place the computer upright or turn it over. If the computer is exposed to an extremely strong impact, it may become damaged.

- Operating environment

Temperature:

Operation : -10 °C to 50 °C {14 °F to 122 °F} (IEC60068-2-1, 2)\*\*1

Storage : -20 °C to 60 °C {-4 °F to 140 °F}

Humidity:

Operation : 30% to 80% RH (No condensation)

Storage : 30% to 90% RH (No condensation)

Even within the above temperature/humidity ranges, operation for a long time in extreme environments, smoking nearby, or operation in places where oil is used or where there is a lot of dust will result in the product deterioration and will shorten the product life.

If the computer is wet in temperatures of 0 °C {32 °F} or below, freeze damage may occur. Make sure to dry off the computer in such temperatures.

\*1 : Do not expose the skin to this product when using the product in a hot or cold environment. (  OPERATING INSTRUCTIONS - Read Me First "Safety Precautions")

- Do not place the computer in the following areas, otherwise the computer may be damaged.
  - Near electronic equipment. Image distortion or noise may occur.
  - In extremely high or low temperature.
- As the computer can become hot during operation, keep it away from items that are sensitive to heat.

### Handling cautions

This computer is designed to minimize shock to parts such as the LCD and the flash memory drive and equipped with a drip-proof keyboard, but no warranty is provided against any trouble caused by shock. Be extremely careful when handling the computer.

- When carrying the computer:
  - Turn off the computer.
  - Remove all external devices, cables, Smart Cards and other protruding objects.
  - Do not drop or hit the computer against solid objects.
  - Do not grip the display part.
- When you board an airplane, take the computer with you and never put it in your checked luggage.
- When using the computer on airplane, follow the airline's instructions.
- When carrying a spare battery, put it in a plastic bag to protect its terminals.
- Be careful not to get injured by dropping or getting hit when carrying the computer.
- Avoid any harmful substances such as oil from getting into the screen. The pointer may not work correctly.
- Use only the included digitizer pen to touch the screen. Do not place any object on its surface and do not press down strongly with sharp-pointed or hard objects that may leave marks (e.g., nails, pencils and ball point pens).
- Touch the screen with your fingers or the digitizer pen (included).  
When touching the screen, use only your fingers or the digitizer pen (included) on the surface.  
Touching the screen with an object other than your fingers or the digitizer pen (included) (a fingernail or metal object, or other hard or sharp objects that may leave a mark) may scar or stain the surface, causing the malfunction.
- Do not use the screen when dust or dirt (e.g., oil) is on the screen.  
Otherwise foreign particles on the screen/digitizer pen can scratch the screen surface or obstruct the digitizer pen operation.
- Do not apply too much pressure when operating the screen.  
Only a light touch is required to operate the screen. Applying too much pressure may damage the surface.

## Handling the screen

- Do not apply strong pressure to the screen outside of the LCD display.  
Applying strong pressure to the screen outside of the display area may result in malfunctions or damage to the LCD screen.
- Do not apply excessive force to the screen.  
Do not place any objects on the LCD screen. Any of the above may cause the screen glass to break, or may damage the LCD screen.
- Operation response may be slower in low temperature environments.  
The screen may respond to operations more slowly when using the computer in temperatures less than 5 °C {41°F}, but this is not a malfunction. Response time will return to normal when the computer is returned to room temperature.
- If the pointer jumps to a location other than where the screen was touched, or if the LCD resolution changes, recalibrate the screen.  
Perform the procedure of "[Calibrating the Screen](#)".

## Handling the digitizer pen (included)

- Clean the digitizer pen tip and screen prior to operation.  
Foreign particles can scratch the screen and impede the operation of the digitizer pen (included).
- Use only the digitizer pen to touch the screen.  
Using it for any other purpose may damage the digitizer pen and result in scratches on the screen.
- The pointer cannot follow the digitizer pen movement if you move the digitizer pen too quickly.
- Do not apply excessive force to the tip of digitizer pen.  
The tip of the digitizer pen (A) is equipped with a sensor. Continued applied pressure to the tip may result in its malfunction or degradation. Make sure excessive pressure is not applied to the tip when storing the digitizer pen.

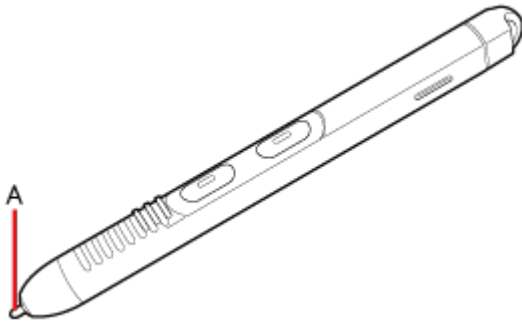

- The digitizer uses electromagnetic induction and may not work properly near strong electrical field or magnetic field.  
such as:
  - Near AM radio base station or relay station antennas
  - Near CRT displays that generate strong electromagnetic field noiseMove the digitizer away from such locations so it will work properly.

## When using peripheral devices

Follow these instructions and this Manual to avoid any damage to the devices. Carefully read the instruction manuals of the peripheral devices.

- Use the peripheral devices conforming to the computer's specifications.
- Connect to the connectors in the correct direction.
- If it is hard to insert, do not try forcibly but check the connector's shape, direction, alignment of pins, etc.
- If screws are included, fasten them securely.
- Remove the cables when you carry the computer. Do not pull the cables forcibly.

## Preventing your computer from unauthorized use via wireless LAN/Bluetooth/wireless WAN

<Only for model with wireless LAN/Bluetooth/wireless WAN>

- Before using wireless LAN/Bluetooth/wireless WAN, make the appropriate security settings such as data encryption.

## Battery Recalibration

The battery recalibration may take a long time due to the large battery capacity. This is not a malfunction.

<When performing “Battery Recalibration” after shutting down Windows>

- Full charge: Approximately 3.5 hours (with FZ-VZSU84A series) / Approximately 3.5 hours (with FZ-VZSU88U)
- Complete discharge: Approximately 3.0 hours (with FZ-VZSU84A series) / Approximately 7.0 hours (with FZ-VZSU88U)

When performing “Battery Recalibration” without shutting down Windows, it may take more time to charge / discharge.

## Battery duration

Note that the computer consumes electricity even when the computer power is off. If the battery pack is fully charged, the battery will fully discharge in the following period of time:

Status	Discharge period	
	FZ-VZSU84A series	FZ-VZSU88U
When power is off	Approx. 7 weeks	Approx. 14 weeks
In sleep	Approx. 10 days	Approx. 20 days
In hibernation	Approx. 7 weeks	Approx. 14 weeks

The battery duration while the USB port continuous charging function is not used.  
The above value is the holding time at room temperature.

## When the battery indicator does not light on

The battery indicator may not light on even if the AC adaptor and the battery pack are correctly connected to the computer, due to the following reasons.

- The AC adaptor’s protection function may be working. In this case, pull out the AC cord and wait for more than 1 minute before reconnecting the AC cord.

## Sensors



This computer is equipped with four sensors (acceleration sensor, gyro sensor, magnetic sensor, ambient light sensor), and you can use these sensors with any software that is compatible.

As the accuracy of each sensor output is dependent on the operating environment and other conditions, the results should only be used as a reference.

The acceleration sensor, gyro sensor, and magnetic sensor are located at the bottom left of the LCD. The detection results of each sensor may vary depending on how you are holding the computer, the application software you are using, and other factors.

### Automatic brightness adjustment

The computer is equipped with an automatic brightness adjustment function that adjusts the display screen based on the ambient light sensor. You can configure the automatic adjustment function as follows.

1. Touch  (Start) -  (Settings) - [System] - [Display].
2. Add the check mark to [Change brightness automatically when lighting changes] under “Brightness and color”.

- The [Change brightness automatically when lighting changes] item may not be available in some cases. In such cases, touch the arrow to the left of [Settings] at the top left of the screen, and perform the operation from [System] - [Display] again.

The ambient light sensor is located at the top of LCD.

The ambient light cannot be detected properly if this area is obstructed or dirty.

### Magnetic sensor

The magnetic sensor on the computer operates by detecting geomagnetism. Therefore, the magnetic sensor may not function properly and its readings may be inaccurate, especially in the following environments.

- Inside or near steel structures such as buildings or bridges
- Inside or near automobiles, or near train power lines
- Near metallic furniture or appliances

- When the AC adaptor or other peripheral devices are brought closer to the computer
- Near magnets, speakers, or other objects with strong magnetic fields

The magnetic directions indicated by the magnetic sensor may not be accurate immediately after purchase or in environments with poor magnetic fields.

In such cases, turn on the computer and move it as follows.

1. **Hold the computer so that its screen side is facing upward and level.**
2. **While keeping the computer level, rotate it 90 degrees or more clockwise.**
3. **Return the computer to position 1, and rotate it 90 degrees or more counterclockwise.**
4. **Return the computer to position 1.**
5. **Tilt the computer 90 degrees or more to the left so that the left side of the computer tilts down.**
6. **Return the computer to position 1, and tilt it 90 degrees or more to the right so that the right side of the computer tilts down.**

- Hold the computer firmly when moving it. Strong shocks from dropping the computer may result in damage.

## Maintenance

If drops of water or other stains get on the surface of the LCD panel, wipe them off immediately. Failure to do so may result in staining.

### Cleaning the LCD panel

The screen is specially treated to prevent dirt from adhering to the surface. Also, to improve the outdoor visibility of the display, a low reflection coating has been added.

When removing the dirt on the screen surface, use only an approved soft cloth in order to avoid scratches and peeling of the coating.

Before using the computer, be sure to read the instructions provided below.

- Be sure to wipe the LCD display to remove fingerprints, etc., with the soft cloth (included).
- How to use the soft cloth
  - Use the soft cloth when it is dry. Do not apply water or solvents to the soft cloth.
  - First, lightly wipe foreign particles and dust adhering to the LCD display on one side of the soft cloth. Do not use force, since the LCD surface may be damaged with the foreign particles or dust.  
Next, wipe off fingerprint, etc., with the other side of the soft cloth.  
After wiping off foreign particles and dust, wash the soft cloth (refer to the following) to remove the foreign particles and dust from the soft cloth.
  - When the soft cloth becomes dirty, wash it with neutral detergent. Do not use bleach or a fabric conditioner (softener), or carry out sterilization by boiling.
  - If the LCD gets wet, wipe the surface lightly with the soft cloth.
  - While wiping the LCD panel, the computer must be turned off.
- Clean the screen while the computer is powered off.  
Cleaning the screen while the power is on may cause the computer to malfunction. Also, dirt on the screen is easier to see when the computer is powered off, and so is easier to clean.
- Wash the soft cloth when it becomes dirty.  
When the soft cloth becomes dirty, wash it with mild detergent. Do not use bleach or fabric conditioner (softener), or try to sterilize the cloth by boiling.  
If the soft cloth is dirty, it may be ineffective in cleaning the screen, and in fact may cause dirt to adhere to the screen.
- Check the following to prevent the surface of the screen from being scratched.
  - Are you using your fingers or the digitizer pen (included) to operate the screen?
  - Is the surface clean?
  - Is the soft cloth clean?
  - Are your fingers clean?

- Are you using the digitizer pen (include) with the tip extended?
- Is the tip of the digitizer pen (include) clean?

## Cleaning areas other than the LCD panel

Wipe with a soft dry cloth such as gauze. When using detergent, dip a soft cloth in water-diluted detergent and wring it thoroughly.

- Do not use benzene, thinner, or rubbing alcohol since it may adversely affect the surface causing discoloration, etc. Do not use commercially available household cleaners and cosmetics, as they may contain components harmful to the surface.
- Do not apply water or detergent directly to the computer, since liquid may enter inside of the computer and cause malfunction or damage.
- Use a soft, dry cloth to wipe droplets of water from the surface of the unit. Do not use a microwave to dry the unit. Doing so will result in malfunction or damage.

## To clean inside of the dust cover

Approximately once a month, clean up inside of the dust cover by the following procedure.

1. Turn off the computer and remove the AC adaptor.
2. Turn over the computer, and remove the battery pack.
3. <Only for model with Built-in Bridge Battery>  
Wait for about 1 minute.
4. Remove the screw (A) and dust cover as illustrated below.

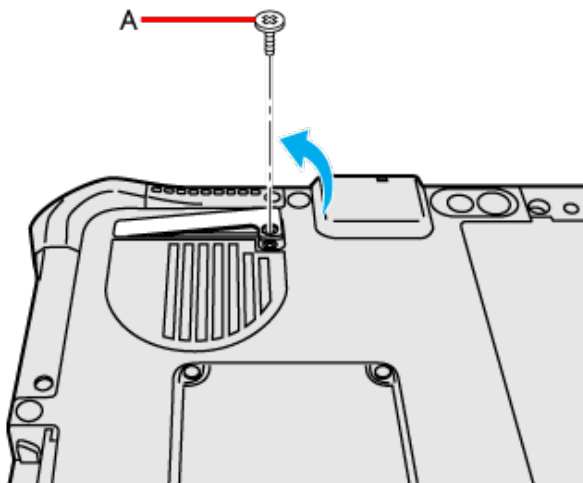

5. Clean up inside of the dust cover.
6. Set the dust cover, screw and battery pack.



## microSD Memory Card

<Only for model with microSD Memory Card slot>

The microSD memory card slot on this computer accepts microSD/microSDHC/microSDXC memory cards.

### Inserting/Removing microSD Memory Card

- Do not remove or insert the SD Memory Card until Windows has completed loading.
- Do not remove the card or turn off the computer in the following cases, otherwise the data may be corrupted.
  - While the computer is in sleep or hibernation.
  - While data is being read from or written to the card.
  - Immediately after the writing operation, this computer may still continue the access to the card. If you remove the card before the operation is completed, the data may be damaged or the card access may no longer be performed normally.
- Note that Panasonic assumes absolutely no liability for any loss of data recorded by the user, or any other damages, direct or indirect.
- Keep SD Memory Cards Away from Infants and Small Children.

#### To insert the card

1. Open the cover (A).
2. Insert the microSD memory card to the microSD memory card slot (B).

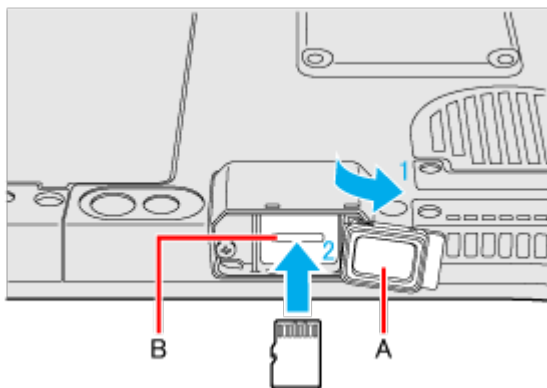



If you turn the computer over, make sure there are no foreign objects under the computer.

3. Close the cover (A).

#### To remove the card

##### Preparation

- Save the data and close all applications.
1. Disable the card function.
    1. Touch  on the task tray and touch .
    2. Select the card.
      - These steps are not necessary when:
        - Removing the card after turning off the computer.
        -  is not displayed.
        - The card does not appear in the list.
  2. Open the cover (A).

3. **Remove the card.**

1. Press the card so it comes out of the slot.
2. Draw it straight out.

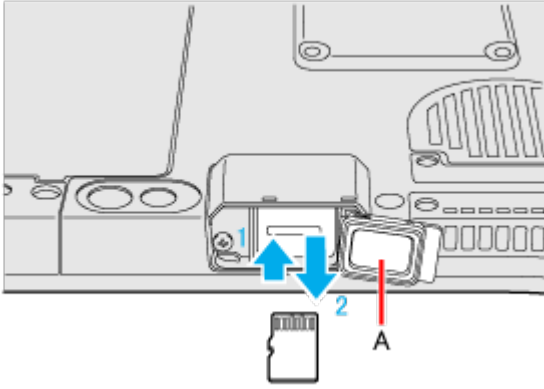

If you turn the computer over, make sure there are no foreign objects under the computer.

4. **Close the cover (A).**

- **After pressing the microSD memory card, do not release your finger suddenly. The microSD memory card may jump out.**

## Smart Card

<Only for model with Smart Card slot>

You need software to use a Smart Card.

### Do not:

- Hit, bend, or drop the card.
- Touch the contact part with fingers or metal object.
- Place the card in very hot location for a long time.
- Remove the card immediately after inserting it.

## NOTE

### <Only for model with dual lock Smart Card Reader>

It is necessary to equip the computer with the hand strap and the large corner guards. About the equipment, contact Panasonic Technical Support.

## Inserting/Removing the Smart Card

### To insert the card

1. Slide the cover (A).

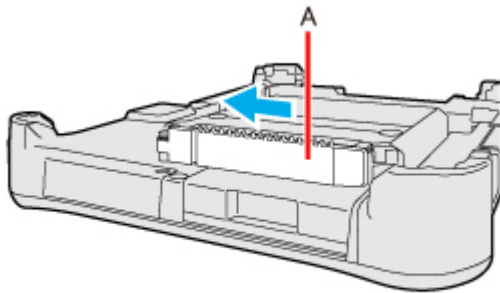

If turn your computer over, make sure no foreign objects are under the computer.

2. Open the cover (B) and insert the Smart Card (C) to the slot (D) with the contact part (E) in front.
  - Insert the card until it securely fits into the slot.

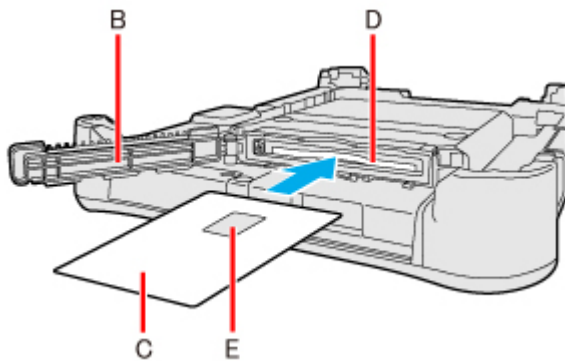

If turn your computer over, make sure no foreign objects are under the computer.

3. Close the cover (A).

- The card stops halfway. Do not push the card forcibly furthermore.

<Only for model with dual lock Smart Card Reader>

1. Open the cover while pushing the projection parts (G) inward.

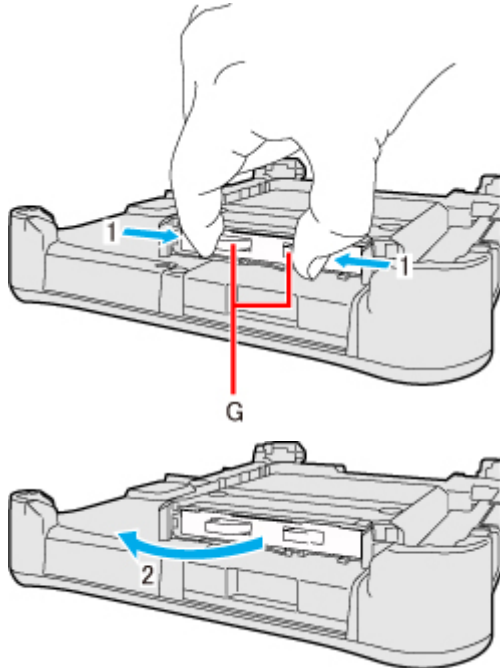

If turn your computer over, make sure no foreign objects are under the computer.

2. Insert the Smart Card (I) to the slot (H) with the contact part (J) in front.

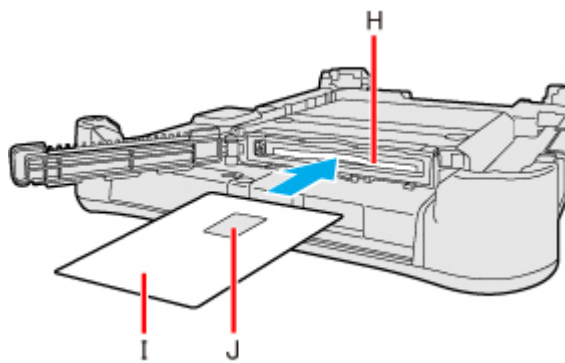

To remove the card

1. Press the eject button (A).

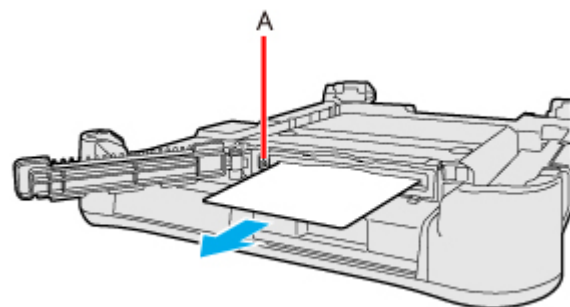

If turn your computer over, make sure no foreign objects are under the computer.  
The Smart Card pops out.

2. Draw the card straight out.

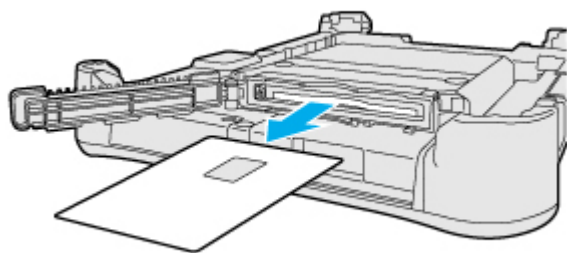

3. Close the cover.

## Magnetic Stripe Card Reader

<Only for model with Magnetic Stripe Card Reader>

You need software to use a Magnetic Stripe Card Reader.

---

### Do not:

- Hit, bend, or drop the card.
  - Touch the contact part with fingers or metal object.
  - Place the card in very hot location for a long time.
  - Remove the card immediately after inserting it.
- 

---

## Reading Magnetic Stripe Card

---

Insert the magnetic tape part of the card into this unit's card reading part and slide it.

- Face the magnetic tape of the card to the computer side.
- You can slide the card from both sides to read.

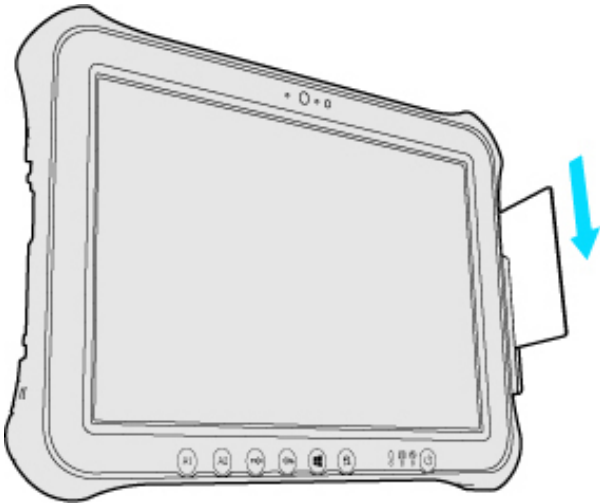

### NOTE

- Slide the card parallel to the rail.
  - Slide the card at a constant speed.
  - Inserting the card at an angle to slide or removing the card at an angle after insertion may lead to incorrect reading.
-

## Barcode Reader

<Only for model with Barcode Reader>

### Preparation

Before using the barcode reader, you need to install the Barcode Integrated Utility.

#### Installing the Barcode Integrated Utility

1. Touch  (Explorer) on the taskbar, and open the "c:\util\bcr\_integrated" folder.
2. Touch and hold [setup.exe] in the "bcr\_integrated" folder, and touch [Run as administrator].  
When the extension is not displayed, touch [View] in Explorer, and add the checkmark to [File name extensions].

Follow the on-screen instructions.



### Reading the Barcode

- Do not look directly into the reading window.  
DO NOT LOOK DIRECTLY AT THE BARCODE READER LIGHT.

[2D Barcode Key Emulator] enables:

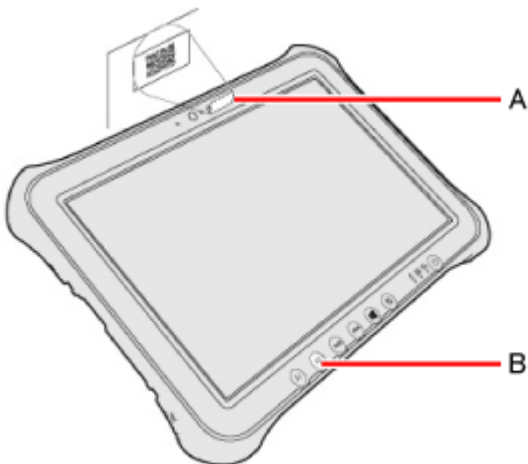
- it makes sound when reading barcode is successful.
- it reads barcode with 2 bytes code.



1. Touch  (Start) -  (Panasonic PC Settings Utility) -  (Utilities) - [2D Barcode Key Emulator].
2. Touch [Connection to Barcode (Always-On)].
3. Open the software for reading a barcode, and put the cursor on it.
4. Aim the Barcode Reader (A) at the barcode.

5. Press  button (B).  
The Barcode Reader lights red to indicate the reading position.

- COM Port of Barcode Module is occupied during reading barcode by Barcode Key Emulator. When reading barcode by Barcode Key Emulator is not necessary, touch [Connection to Barcode (Always-On)] in [2D Barcode Key Emulator].

## NOTE

- When the barcode read operation is finished, please wait about three seconds to start the next reading. You may press the button immediately, even if you set to release, it takes several seconds to light to light actually.
- If an error message appears and nothing is displayed, restart this utility.



- To disable the automatic rotation of the screen when reading the barcode, press the [Rotation Lock Button](#).
- When the computer has resumed from sleep and hibernation, an error may appear and the connection with this utility may be lost. If this occurs, perform step 1.

## To Correctly Read a Barcode with This Computer, Observe the Following

- The reading angle is important factor.  
Perform reading at the angle indicated in the figure. We recommend you to set at approximately 2° to 3° angle from the perpendicular position.

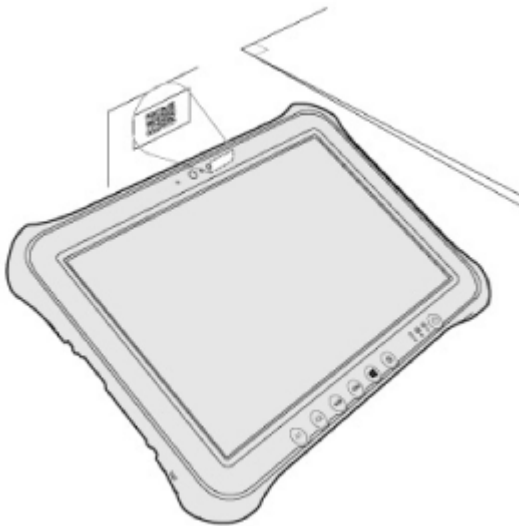

- Hold the reader farther away when reading a larger barcode, and closer in when reading a smaller barcode.
- Perform reading so that the entire symbol falls within the center of the red Barcode Reader light. The reader can still read a barcode even if the barcode is not in the center of the red Barcode Reader light. However, if a part of the barcode lies outside the Barcode Reader light, the barcode cannot be read. Make sure the entire barcode is inside the Barcode Reader light.

Correct

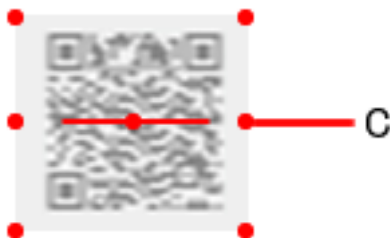

Incorrect

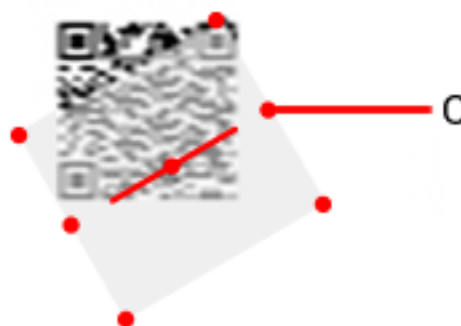

C. Barcode Reader Light



## Cleaning the Reading Window

If the reading window is dirty, gently wipe the reading window with a cloth or a cotton swab moistened with water. Do not allow materials that can easily scratch the reading window to touch the window, such as sandpaper or metal object.

For parts other than the reading window, please read "[Handling and Maintenance](#)".

## Decode Capabilities

Following symbologies are supported as the factory default.

Codabar, Code 128, EAN 128, Code 39, DataMatrix, Interleaved 2 of 5, PDF417, QR Code, RSS-14, RSS Limited, RSS Expanded, UPC-A, UPC-E, EAN-8, EAN-13

Following symbologies also can be used by specifying them with Barcode Configuration Utility.

Codablock A, Codablock F, Code 11, Code 128 French CIP, EAN 128 Irregular, ISBT, Code 93, EAN.UCC Composite CC-A/B, EAN.UCC Composite CC-C, EAN.UCC Composite Linear, ISBN, ISMN, ISSN, Matrix, Maxicode, MicroPDF417, MSI, Plessey, Standard 2 of 5, Telepen, UPC-E1, TLC 39, Australian Post, BPO, Dutch Post, Japan Post, Planet, Postnet, Canada Post, Infomail, Sweden Post

## Using Software

### Barcode Configuration Utility

Using the Barcode Configuration Utility, you can create and perform the configuration files to set up the settings.

1. **Sign in to Windows as an administrator.**

2. Touch  (Start) -  (Panasonic PC Settings Utility) -  (Utilities) - [Barcode Configuration].

If the "User Account Control" screen appears, touch [Yes].

If you want to reflect/create a barcode configuration file, touch [Barcode Configuration Utility].

3. **Touch target model, and then touch [OK].**

Usually choose [2D Barcode Reader Type A Series].

4. **Make necessary setting.**

- If you want to set the type of barcode
  1. Touch [Barcode standard configuration] tab.
  2. To deploy the barcode standard you want to set.
  3. Select [Disabled] or [Enabled] in [ACTIVATE].
- If you can set up a data editing function of barcode reader
  1. Touch [Data configuration] tab.
  2. Make necessary settings.  
You can write in the edit box what you want to set each item, and is to be selected in the pull-down list.
- Revert to the factory default state of the machine settings
  1. Touch [Set Baseline Settings] button on each tab.
  2. At the confirmation message, select [Yes].

### NOTE

- In each setting tab, only items that need to be set, please put a check in the check box. If you do not want to change any settings, please do not put it in check.

5. **Create and reflect the barcode configuration file.**

- When creating a barcode configuration file
    1. Touch [File] - [Save as].
    2. Save the barcode configuration file.
  - When creating and reflecting the barcode configuration file
    1. Touch [Tool] - [Apply Configuration].
    2. Save the barcode configuration file.

The setting of the barcode configuration file will be reflected.
  - If you want to reflect the barcode configuration file you created
    1. Touch [File] - [Open], open the barcode configuration file.
    2. Touch [Tool] - [Apply Configuration].
6. **Touch [File] - [Exit].**  
At the confirmation message, select [Yes].

## Application of INI file

1. **Create the Barcode Configuration File (\*.INI File).** (  [When creating a barcode configuration file](#) )
2. **Barcode configuration file that you created by dragging and dropping the Barcode Configuration Utility (.exe), can be reflected in the barcode reader module.**
  - The execution file is stored below:
    - <For 32-bit OS>  
C:\Program files\Panasonic\BCR2D\_A\_Set\BCR2D\_A\_Set.exe
    - <For 64-bit OS>  
C:\Program Files (x86)\Panasonic\BCR2D\_A\_Set\BCR2D\_A\_Set.exe

With this method, you can reuse the INI file or make settings for another PC.

## External Display

You can switch the output destination to an external HDMI display.

1. Slide the cover (A).

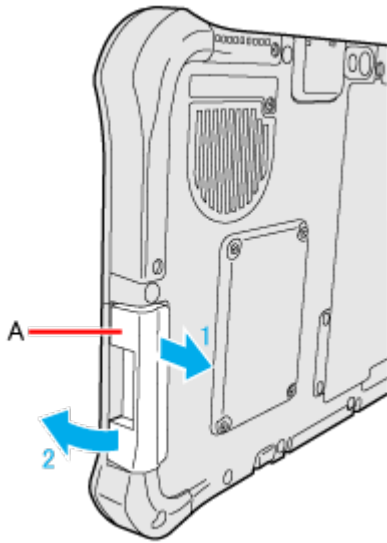

2. Open the cover (A) and connect the HDMI display to the HDMI display port (B).

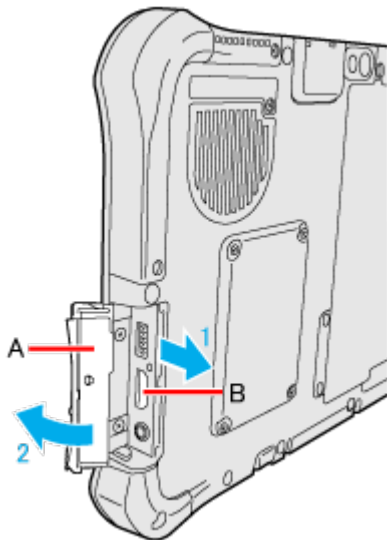



<Only when connected to Cradle>

You can also switch the output destination to an analog display.  
Connect the external display to the VGA port of the cradle.

---

## Switching the display mode



---

1. Touch  (Start) -  (Settings) - [System] - [Display].
2. Settings the "Multiple displays".

### NOTE

- After switching the display mode, the display resolution may change.
  - After resuming from sleep or hibernation, or restarting the computer, the output destination may not be the same as selected in the previous status.
  - When you change the display after Windows starts up, do not press any button until switching is complete.
-

- Do not connect or remove the external display during sleep or hibernation.
- It may take some time to switch between displays depending on the displays used.
- When you use the external display only, set the suitable number of colors, resolution, or refresh rate separately from when you use the internal LCD only or when you use the simultaneous display.  
Depending on the settings, some external displays may be distorted or may not display the mouse pointer correctly. In this case, set the settings to lower value.
- When you use the simultaneous display, MPEG files and other motion image files may not be played back smoothly.
- Carefully read the instruction manual of the external display.
- When connecting an external display that does not conform to the Plug & Play standards, select the display driver accordingly in the following menu, or use the driver disc supplied with the monitor.

1. Touch  (Start) -  (Settings) - [System] - [Display].
2. Touch [Advanced display settings] under "Multiple displays".
3. Touch [Display adaptor properties for Display \*].  
\* is a display number.
4. Touch [Monitor] - [Properties].
5. Touch [Driver] - [Update Driver].

- An external display connected to the cradle (optional) can also be switched.

- The screen may become distorted due to the following operations. In this case, restart the computer.
  - Disconnecting an external display for which you have set high resolution or high refresh rate.
  - Connecting/disconnecting an external display during computer operations.

## To Change the Display Settings

1. Touch  on the task tray, and then touch  (Intel® Graphics Settings) - [Intel® Graphics Settings].  
Alternatively, touch and hold the desktop, and then touch [Intel® Graphics Settings] in the desktop mode.
2. Touch [Display].
3. Set the display color and resolution etc.
4. Touch [Apply].
5. Touch [Yes].

### Extended Desktop

## NOTE

- It may not be possible to use the extended desktop with some software applications.
- When you touch the maximize button, the window is displayed on one of the displays. You cannot move the maximized window to the other display.
- Do not use the display rotation in the extended desktop.
- While using an extended desktop or [Second screen only], you cannot operate the external display screen with touch operation.
- Set the internal LCD to the primary display when using the screen. The pointer will move on the primary display when you touch the internal LCD.

## Connecting/Removing USB Devices

To connect the USB device

1. Slide the cover (A).

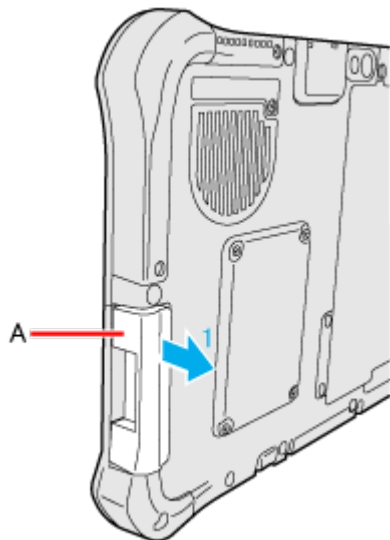

2. Open the cover (A) and connect the USB device to the USB 3.0 port (B).

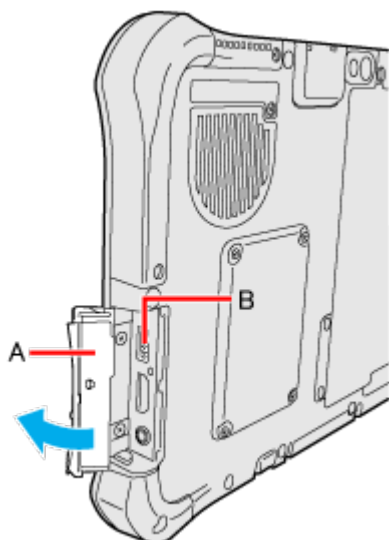

<Only for model with 2nd USB port>

Open the cover (C) and connect the USB device to the USB 2.0 port (D).

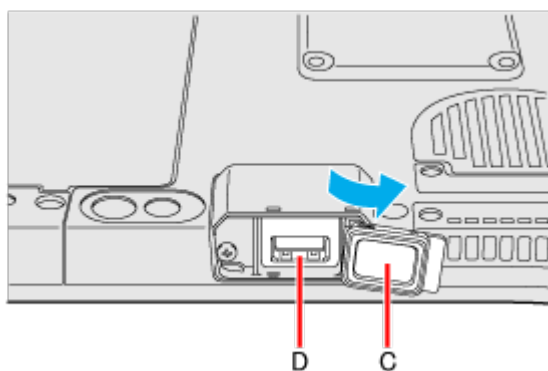

If you turn the computer over, make sure there are no foreign objects under the computer.

## To remove the USB device

### 1. Disable the USB device.

1. Touch  on the task tray at the bottom right corner of the screen and touch .
2. Select the USB device.

• These steps are not necessary when;

- Removing the device after turning off the computer.

•  is not displayed.



- The device does not appear in the list in step 2.

### 2. Remove the USB device.

<Only for model with Smart Card slot>

- If you double-touch , [USB Smart Card Reader] is displayed in the list, but do not select this item. Removing this item is not possible. Restart the computer in case you select this.

## NOTE

- You may need to install the driver for the USB device. Follow the on-screen instructions or refer to the instruction manual of the USB device.
- You may need to install the driver again when connecting the device to another port.
- When a USB device is connected, sleep or hibernation may not function normally. If the computer does not start up normally, remove the USB device and restart the computer.
- When the USB device is removed and then inserted while the computer is on,  or  may appear in the Device Manager and the device may not be correctly recognized. In this case, remove and connect the device again, or restart the computer.
- When a USB device is connected, power consumption increases. Remove the USB device when it is not in use, especially when operating by battery power.
- If the computer enters the sleep mode while an external keyboard or mouse is connected, touching the external keyboard keys or mouse may resume the computer.

<Only for model with serial port>

### Connecting Serial device

1. Connect the cable.

- Open the cover (A) and connect the serial port (B) and the serial conversion cable.

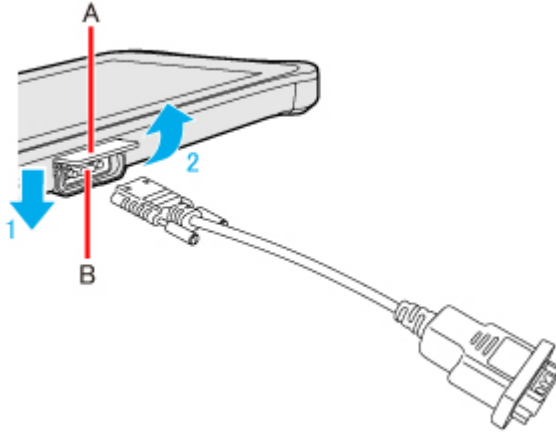

2. Connect the serial device to the connector of the serial conversion cable.

### NOTE

- When connecting a cable, be sure to secure it with screws (C).

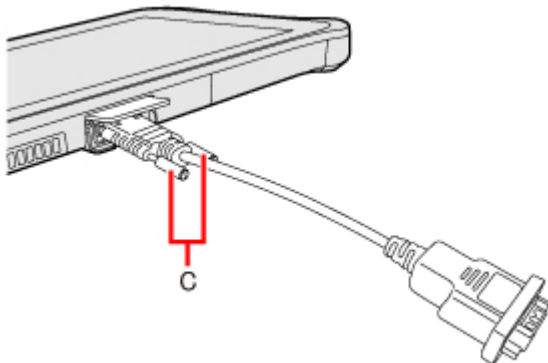

- It does not support serial mouse.

## Using the Camera

For the camera position and functions, refer to "[Description of Parts](#)".

### NOTE

- When the camera is in use, the Camera Indicator lights up. (Even if [Concealed Mode] is set to [Enabled] and [LED] to [OFF], the camera indicator cannot be turned off.)
- When the computer is moved from hot and humid environment to low temperature environment, dew condensation may form on the lens. This is not a malfunction. Wait until the lens dries out.

<Only for model with front/rear camera>

## Panasonic PC Camera Utility

The Panasonic PC Camera Utility can be used to shoot photos and videos.

When you use pictures and videos recorded using this utility at Web conferences, or other services, use specialized applications accordingly.

### NOTE

- If you use this utility and other multi-media software at the same time, an error may occur. Close all multi-media software including this utility and restart this utility.
- If an error message appears and nothing is displayed, restart this utility.
- When the computer has resumed from sleep and hibernation, an error may appear and the connection with the camera device may be lost. If this occurs, restart this utility.
- Panasonic PC Camera Utility only with the built-in camera. It does not support a camera connected to the computer.

## Starting up

1. Touch  (Start) -  (Panasonic PC Camera Utility).

The Panasonic PC Camera Utility starts up, and the following screen is displayed.

- When the utility is running, do not remove or insert audio devices (such as microphones and speakers). Also, do not enable or disable such devices.

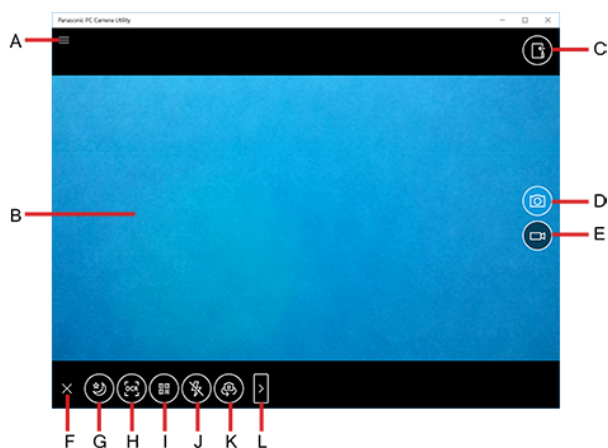









- A. Open the camera settings
- B. Preview screen



- C. Display the folder where recorded data is saved
- D. Shoot photos
- E. Start/Stop shooting videos
- F. Hide the mode menu
- G. Night Mode switching
- H. OCR <Only for model with rear camera>
- I. Barcode reader <Only for model with rear camera>
- J. Camera light <Only for model with rear camera>
- K. Switch camera <Only for model with multiple cameras>
- L. Zoom <Only for model with rear camera>

## Shooting Photos and Videos

Touch focus / auto exposure adjustment	<ol style="list-style-type: none"> <li>1. Touch the subject in the preview screen. <ul style="list-style-type: none"> <li>• The focus is adjusted to the subject, and the exposure is adjusted automatically.</li> </ul> </li> </ol>
Shoot photos	 <ol style="list-style-type: none"> <li>1. Touch  . <ul style="list-style-type: none"> <li>• You cannot shoot photos when the save destination storage space is less than 10 MB.</li> </ul> </li> </ol>
Start/Stop shooting videos	<ol style="list-style-type: none"> <li>1. Touch  . The camera switches to the video shooting mode.</li> <li>2. Touch  .  During shooting, the icon is shown as  .</li> <li>3. To stop shooting, touch  . <ul style="list-style-type: none"> <li>• If the save destination storage space becomes less than 100 MB during video shooting, shooting will automatically stop.</li> </ul> </li> </ol> <div style="background-color: #0070C0; color: white; padding: 5px; margin-top: 10px;"><b>NOTE</b></div> <ul style="list-style-type: none"> <li>■ Shooting will stop when you minimize the application window, or put the computer into the hibernation mode during video shooting.</li> </ul>
<b>Turn the Night Mode ON</b> To make the dark viewing image brighter	<ol style="list-style-type: none"> <li>1. Touch  .  When using the Night Mode, the icon is shown as  .</li> </ol> <div style="background-color: #0070C0; color: white; padding: 5px; margin-top: 10px;"><b>NOTE</b></div> <ul style="list-style-type: none"> <li>■ Updating the preview screen may be delayed when using the Night Mode.</li> <li>■ CPU utilization increases when using the Night Mode. If you leave the computer for long hours, the area around the exhaust vent may be heated.</li> </ul>

Display the recorded image or video files





1. Touch .

The recorded data will be saved in the displayed folder named the recording date.

<Only for model with rear camera>



1. Touch . The icon is shown as .

2. Point the window at the target text you want to scan, and touch  on the right side of the screen.

You can turn on the light. Touch .

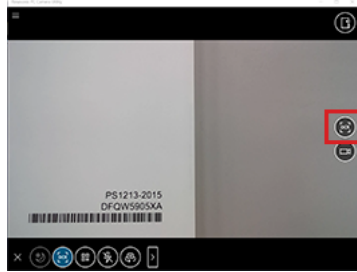

When the target text has been scanned, the scanned OCR text is displayed above the preview window.

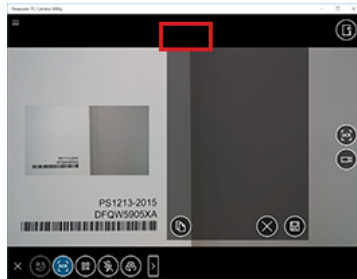

Copy the OCR text to the clipboard.



Retry OCR scanning.





Save the OCR text.









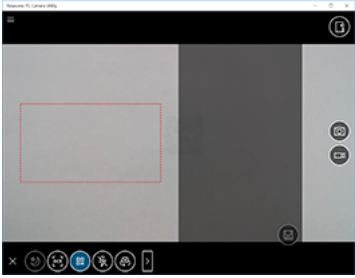
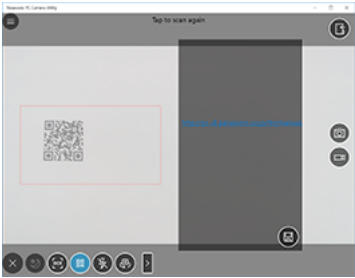

To stop scanning, touch .

## NOTE

- Installation of the language pack is necessary in order to use the OCR feature of other languages. If it is not installed, please download the language pack by the following procedure.

1. Touch  (Start) -  (Settings) - [Time & Language] - [Region & language].
2. Touch [Add a language] under "Languages".
3. Select a language to install, and then touch [Next].
4. Change the "Install language features" if necessary, and then touch [Install]. Restart may be necessary in some cases.
5. Select the "Windows display language" to be used with the OCR feature.
6. Sign out and sign in once.

- OCR feature can't be used in some languages which Windows doesn't support OCR feature.

<p><b>Barcode Reader</b></p>	<ol style="list-style-type: none"> <li>1. Touch . The icon is shown as .</li> <li>2. Point the on-screen guide at the barcode.</li> </ol> <p>You can turn on the light. Touch .</p>  <p>When the barcode has been scanned, the scanned barcode text is displayed on the right side of the preview window.</p>  <p> Save the barcode text.</p>
<p><b>Turn the light ON/OFF</b></p>	<p>You can turn on/off the light.</p> <p> Turn off the light.</p> <p> Turn on the light (Flash available).</p> <p> Turn on the light.</p>
<p><b>&lt;Only for model with multiple cameras&gt; Switch camera</b></p>	<p>Switch between the front and rear cameras.</p> <ol style="list-style-type: none"> <li>1. Touch .</li> </ol>
<p><b>&lt;Only for model camera device with zoom function only&gt; Zoom</b></p>	<p>To enlarge or reduce the camera image.</p> <ol style="list-style-type: none"> <li>1. Use the Zoom slider for adjustment.</li> </ol>  <p>If the slider is not displayed, touch .</p>

1. Touch  - .

The “Settings” menu is displayed.



**A. Mirror setting**

<Only for front camera>

Make the preview screen mirror-reversed (flip horizontal). (Recorded images will not be reversed)

**B. Camera shake correction**

<Only for front camera>

Enable the image stabilizer when shooting photos.

**C. Brightness**

Change the brightness of camera images.

**D. White Balance**

Change the white balance of camera images. To set manually, uncheck the [Auto] option.

**E. Contrast**

Change the contrast of camera images.

**F. Flicker correction**

Set the flickering correction of camera images.

**G. Still picture resolution**

Change the still picture resolution. Perform touch operation or mouse click to select the resolution. The resolution may not be correctly specified if you use the keyboard cursor keys.

**H. Video resolution**

Change the video resolution. Perform touch operation or mouse click to select the resolution. The resolution may not be correctly specified if you use the keyboard cursor keys.

- Note that the described FPS values are theoretical. They may be decreased depending on the actual use conditions.

**I. Burst Mode**

Press and hold the photo shooting button to shoot continuously while the button is pressed. The maximum number of continuous shooting is 20.

- You cannot shoot continuously when using the Night Mode.

**J. Adding a stamp**

Add geolocation and time stamps to still images.

**K. Adding a geotag**

Add geotagging to the Exif data of still images.

L. **Photo storage folder**

Specify the destination of recorded photo data to save. The default value is the “Pictures” folder.

M. **Video storage folder**

Specify the destination of recorded video data to save. The default value is the “Videos” folder.

- If you specify the FAT32 formatted storage as destination to save, video files cannot be correctly created when the storage data capacity exceeds 4 GB.

N. **Save barcode file automatically**

O. **Barcode file storage folder <Only for model with rear camera>**

Specify the destination of saved barcode text. The default value is the “Pictures/Barcode” folder.

P. **Character recognition file storage folder <Only for model with rear camera>**

Specify the destination of saved OCR text. The default value is the “Pictures/OCR” folder.

Q. **Self-Timer**

Specify the time period until shooting starts after the button is pressed. (OFF/5 sec./10 sec.)

R. **Interval Shooting**

When you move the slider to the right, and specify the value except [0], the camera automatically repeats shooting at intervals of specified seconds. The maximum 10 photos can be shot continuously.



S. **Restore default settings**

Return all the settings to the default values.

To close the “Settings” menu, touch  on the upper left of the screen, or touch the preview screen.

## NOTE

- To specify the save destination folder, select the folder you have the access right to. If a writing error occurs, change the specified folder.
- The drive that appears by performing the following procedure will be used as the location in which the “Pictures” and “Videos” folders will be stored.

Touch  (Start) -  (Settings) - [System] - [Storage], and then touch [Change where new content is saved] under “More storage settings”.

## Contactless Smart Card Reader/RFID Reader

<Only for model with Contactless Smart Card Reader/RFID Reader>

You can read the data from RFID (Radio Frequency Identification) tags / Smart Card.

### NOTE

- This sensor is typically used with specialized applications. For further information, ask the system administrator.
- It is necessary to equip the computer with the hand strap and the large corner guards. About the equipment, contact Panasonic Technical Support.

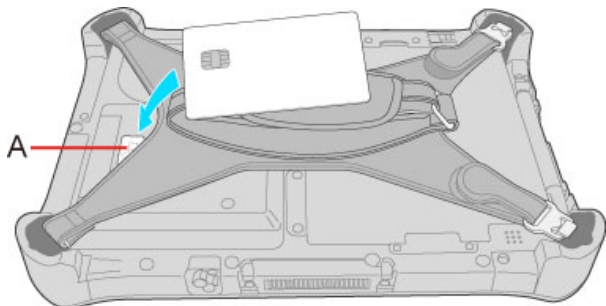

1. **Align the RFID tags / Smart Card with the mark (A) and wave the RFID tags / Smart Card.**  
A Smart Card can be read from its front or reverse side. Try moving its position if it cannot be read.
  - Continue operation by using the specialized applications.

### NOTE

- Operation distance depends on RFID tag / Smart Card.



## Cradle

You can use an optional cradle. This device frees you from being bothered by a lot of cable connections when you carry the computer. It also allows you to connect various peripherals.

Connect the cradle to the expansion bus connector (A) on the bottom side of the computer.

For further information, refer to the instruction manual of the cradle.

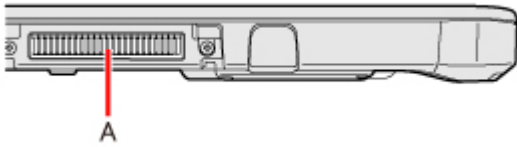

- 
- Connect or disconnect the cradle while the computer power is turned off.
  - To boot the computer from a USB optical drive, be sure to connect the USB drive to the USB port on the computer, not to the USB port on the cradle.
-

## Hand Strap

<Only for model with hand strap>

## Hand Strap

Attaching the hand strap helps you stably hold the computer.

- If the hand strap loosens, the computer may fall down.
- Do not use the strap if it becomes worn or damaged.
- Before using, check if the mounting clips and the screws have been firmly fixed.

## Using the hand strap

1. When using the computer holding with hand, insert your hand to (A) part of the hand strap.

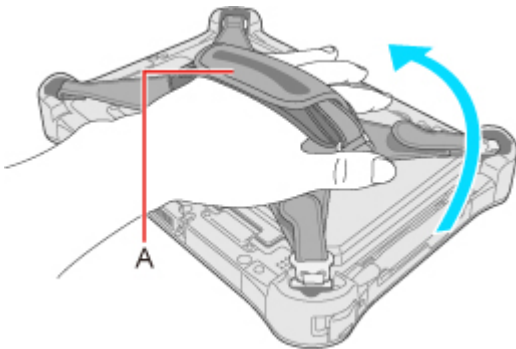

2. Fix the hand strap firmly so that the computer does not come off, and then turn it over.
3. Adjust the angle of the hand strap if it is necessary.

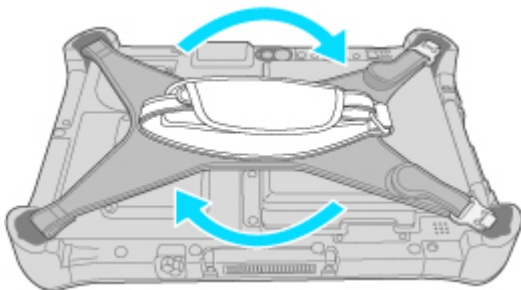

- If the hand is not securely fixed to the hand strap, the computer may drop.

When the hand strap is too loose or too tight, you can adjust the hand strap according to the instructions below.

1. Remove (A) from the strap joint and next remove (B).

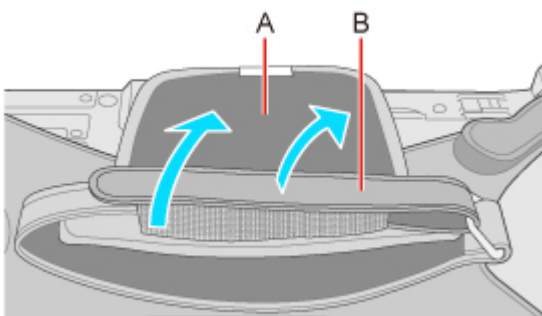

2. Adjust the position (C).

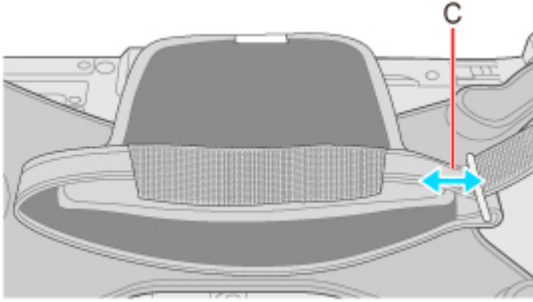

3. Attach (D), then (E) to the joint.

- Attach the hand strap firmly so that the strap does not come off.

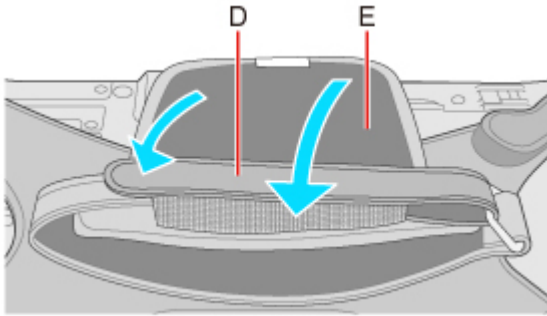

#### When Inserting the Battery Pack / Cleaning inside of the dust cover

- Place the computer on a soft cloth with the panel side down. In addition, make sure that there is no item under the computer.

1. Remove the edge (A) of hand strap passing through the clip. (The illustration shows the top side of hand strap as an example.)

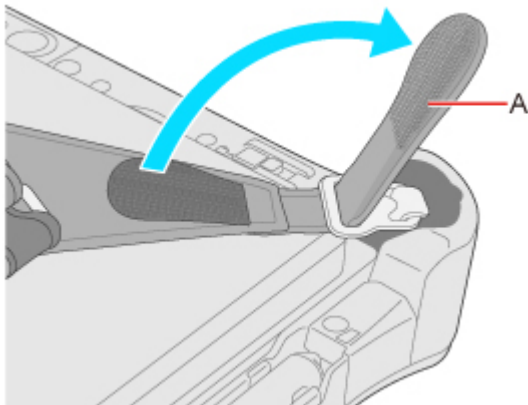

2. Tip the clip (B) back to pull it out of the computer. (Do the same for the bottom side of hand strap.)

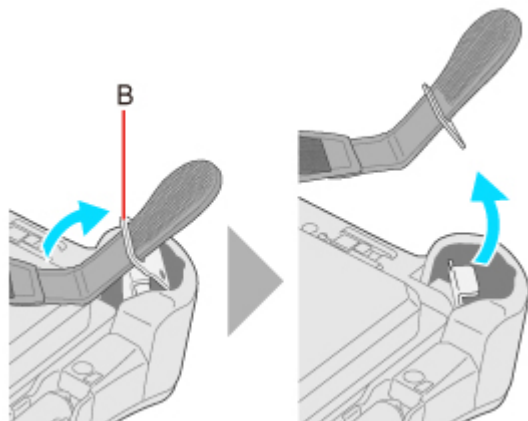

3. Open up the whole hand strap.

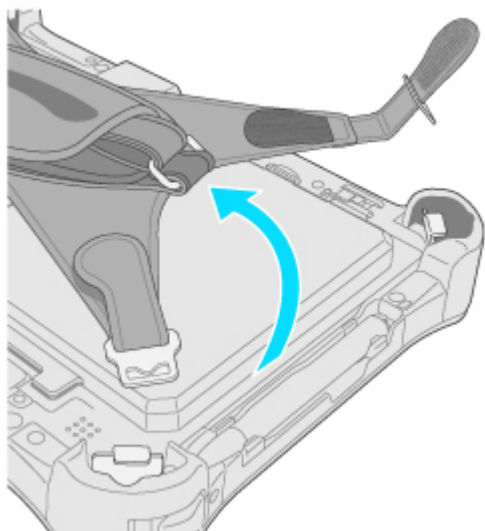





## Troubleshooting





Refer to the following instructions when a problem occurs. If the remedies indicated in the chart do not solve the problem, contact Panasonic Technical Support.

For a software problem, refer to the instruction manual of the software.

- Refer to [Checking the Computer's Usage Status](#).

### Starting Up

<p>Cannot start up. The power indicator or battery status is not lit.</p>	<ul style="list-style-type: none"> <li>• Connect the AC adaptor.</li> <li>• Insert a fully charged battery.</li> <li>• Remove the battery pack and the AC adaptor, and then connect them again.</li> <li>• Even if the AC adaptor and battery pack are correctly connected, if the battery indicator is not lit, the AC adaptor protection function may be operating. Disconnect the AC cord, wait three minutes or more, and reconnect the AC cord.</li> <li>• If a device is connected to the USB port, disconnect the device, or set [USB Port] to [Disabled] in the [Advanced] menu of the Setup Utility.</li> </ul> <p style="text-align: center;"></p> <ul style="list-style-type: none"> <li>• Press  to turn off the concealed mode.</li> </ul>
<p>The power is turned on but “Warming up the system” appears</p>	<p>The computer is warming up before start up. Wait for the computer to start up (the maximum waiting time will be displayed on the screen). If, “Cannot warm up the system” is displayed, the computer failed to warm up and does not start. In this case, turn off the computer, leave it in an environment of 5 °C {41 °F} or higher temperature for about an hour, and then turn on the power again.</p>
<p>Cannot turn on the computer. The computer does not resume from sleep. (The battery indicator blinks green and orange alternately.) (The power indicator blinks rapidly in green.)</p>	<p>Leave it in an environment of 5 °C {41 °F} or higher temperature for about an hour, then turn on the power again.</p>
<p>“Remove disks or other media. Press any key to restart” or a similar message appears.</p>	<ul style="list-style-type: none"> <li>• If a device is connected to the USB port, disconnect the device, or set [USB Port] to [Disabled] in the [Advanced] menu of the Setup Utility.</li> <li>• If the problem persists after disconnect the device, it may be a flash memory failure. Contact Panasonic Technical Support.</li> </ul>
<p>Windows startup and operation is slow.</p>	<ul style="list-style-type: none"> <li>• Start the Setup Utility (  <a href="#">Setup Utility</a> ) to return the Setup Utility settings (excluding the passwords) to the default values. Start the Setup Utility and make the settings again. (Note that the processing speed depends on the application software, so this procedure may not make Windows faster.)</li> <li>• If you installed a resident software after purchase, turn off the residence.</li> </ul>
<p>It takes time for the power indicator to light up.</p>	<p style="text-align: center;"></p> <ul style="list-style-type: none"> <li>• If the power switch  is pressed immediately after the battery pack has been mounted on the computer, and while the AC adaptor is not connected, it may take about five seconds before the power indicator lights up and the computer turns on. This is because the computer is checking the remaining battery charge; it is not a malfunction.</li> </ul>









The date and time are incorrect.	<ul style="list-style-type: none"> <li>• Make the correct settings.           <ol style="list-style-type: none"> <li>1. Touch  (Start) -  (Settings) - [Time &amp; Language] - [Date &amp; time], and check [Off] in "Set time automatically".</li> <li>2. Touch [Change], and then set the day and time.</li> </ol> </li> <li>• If the problem persists, the internal clock battery may need to be replaced. Contact Panasonic Technical Support.</li> <li>• &lt;Only for model with LAN&gt; When the computer is connected to LAN, check the date and time of the server.</li> <li>• The 2100 A.D. or later year will not be correctly recognized on this computer.</li> </ul>
Battery indicator blinking green.	In order to stop the battery from deteriorating, power supply from AC adaptor has been shut off, and the battery power is being consumed. Do not remove the battery pack in this status.
"Executing Battery Recalibration" screen appears.	The Battery Recalibration was cancelled before Windows was shut down last time. To start up Windows, turn off the computer by the power switch  , and then turn on.
Other startup problems.	<ul style="list-style-type: none"> <li>• Start in the Setup Utility (  <a href="#">Setup Utility</a>) to return the Setup Utility settings (excluding the passwords) to the default values. Start the Setup Utility and make the settings again.</li> <li>• Remove all peripheral devices.</li> <li>• Check to see if there was a disk error.           <ol style="list-style-type: none"> <li>1. Remove all peripheral devices including an external display.</li> <li>2. Touch  (Start) - [Windows System] - [This PC].</li> <li>3. Touch and hold [Windows (C:)], and touch [Properties].</li> <li>4. Touch [Tools] - [Check].               <ul style="list-style-type: none"> <li>• A standard user needs to enter an administrator password.</li> </ul> </li> <li>5. Follow the on-screen instructions.</li> </ol> </li> </ul>









## Entering Password

Even after entering the password, password input screen is displayed again.	<p>&lt;Only if the external keyboard is connected&gt;</p> <ul style="list-style-type: none"> <li>• The computer may be in ten-key mode. When Num Lock is on, press « Num Lock » to disable the ten-key mode, and then input.</li> <li>• The computer may be in Caps Lock mode. When Caps Lock is on, press « Caps Lock » to disable the Caps Lock mode, and then input.</li> <li>• Enter the password using the same keyboard that was used to set the administrator password or user password, as the key layouts of the on-screen keyboard and some external keyboards may differ.</li> </ul>
Forgot the password.	<ul style="list-style-type: none"> <li>• Supervisor Password or User Password: Contact Panasonic Technical Support.</li> <li>• Administrator password:           <ul style="list-style-type: none"> <li>• If you have a password reset disk, you can reset the administrator password. Set the disk and enter any wrong password, then follow the on-screen instructions and set a new password.</li> <li>• If you do not have a password reset disk, reinstall (  <a href="#">Installing Software</a>) and set up Windows, and then set a new password.</li> </ul> </li> </ul>

## Shut Down









Cannot turn off the computer.	<ul style="list-style-type: none"> <li>• Remove all peripherals.</li> <li>• It may take 1 or 2 minutes to turn off the computer.</li> </ul>
-------------------------------	---

<p>Cannot enter sleep or hibernation.</p>	<ul style="list-style-type: none"> <li>• Remove USB devices temporarily. If the problem persists, restart the computer.</li> <li>• It may take 1 or 2 minutes to enter sleep or hibernation.</li> <li>• The computer does not enter sleep or hibernation immediately after resuming. Wait approximately 1 minute.</li> </ul>
<p>Cannot enter sleep or hibernation automatically.</p>	<ul style="list-style-type: none"> <li>• Disconnect peripheral devices.</li> <li>• If you connect to a network using wireless LAN function, select the profile and connect to the access point (  <a href="#">Disabling/Enabling Wireless Communication</a> ).</li> <li>• If you do not use wireless LAN function, turn off wireless LAN function (  <a href="#">Disabling/Enabling Wireless Communication</a> ).</li> <li>• Make sure that you are not using any software that regularly accesses the flash memory.</li> </ul>
<p>The computer does not resume.</p>	<div style="text-align: center;"></div> <ul style="list-style-type: none"> <li>• If you press and hold the power switch for 4 seconds or longer, the power will be turned off forcibly and the computer will not resume. In this case, all unsaved data will be lost.</li> <li>• You disconnected the AC adaptor and the battery pack while the computer was in sleep. If the computer's power supply is disconnected in sleep, unsaved data will be lost and the computer will not resume.</li> <li>• The battery is exhausted. Sleep and hibernation consumes some power.</li> <li>• An error may occur when the computer automatically enters the sleep or hibernation mode while the screensaver is active. In this case, turn off the screensaver or change the pattern of the screensaver.</li> </ul>
<p>[Enter Password] does not appear when resuming from sleep/hibernation.</p>	<ul style="list-style-type: none"> <li>• Select [Enabled] in [Password On Resume] in the [Security] menu of the Setup Utility (  <a href="#">Setup Utility</a> ).</li> <li>• The Windows password can be used instead of the password set in the Setup Utility.</li> </ul> <p> Add a password, and set up the following.</p> <ol style="list-style-type: none"> <li>1. Touch  (Start) -  (Settings) - [Accounts].</li> <li>2. Touch [Sign-in options], and touch [Add] under "Password".</li> <li>3. Create a password.</li> <li>4. Touch [Next].</li> <li>5. Select [When PC wakes up from sleep] under "Require sign-in".</li> </ol>
<p>Cannot sign in to Windows using the face recognition for Windows Hello outdoors.</p>	<ul style="list-style-type: none"> <li>• If you have registered the face recognition indoors, you may not sign in to Windows using the face recognition outdoors. In such cases, please add Windows Hello face recognition outdoors. Perform the following procedure.             <ol style="list-style-type: none"> <li>1. Sign in to Windows.</li> <li>2. Touch  (Start) -  (Settings) - [Accounts].</li> <li>3. Touch [Sign-in options].</li> <li>4. Touch [Improve recognition] under "Windows Hello" and then touch [Get Started].</li> <li>5. "Making sure it's you" is displayed, input PIN number.</li> <li>6. Since additional registration of face recognition starts, follow the on-screen instructions.</li> </ol> </li> <li>• If you cannot register the face recognition outdoors properly, try to take the following measures.             <ul style="list-style-type: none"> <li>• In the shade, register your face with your back against the wall that does not reflect the light.</li> <li>• Place the tablet vertically to block the sunlight, and register your face.</li> </ul> </li> </ul>

<p>No display.</p>	<ul style="list-style-type: none"> <li>• The display is turned off by the power-saving function. Touch the screen.</li> <li>• The computer entered sleep or hibernation by the power-saving function. To resume, press the power switch .</li> <li>• When using an external display,             <ul style="list-style-type: none"> <li>• Check the cable connection.</li> <li>• Turn on the display.</li> <li>• Check the settings of external display.</li> </ul> </li> </ul>
<p>The screen is dark.</p>	<ul style="list-style-type: none"> <li>• The screen is darker when the AC adaptor is not connected. Touch  or  on the task tray, and then touch  to adjust the brightness. As you increase the brightness, battery consumption increases.</li> <li>• Press  to turn off the concealed mode.</li> <li>• Under factory default settings, the brightness of the display screen will adjust automatically based on the ambient light detected by the ambient light sensor. You can adjust the settings for this sensor. (  <a href="#">Automatic brightness adjustment</a> )</li> </ul>
<p>Takes time to display "Power Options" screen.</p>	<ul style="list-style-type: none"> <li>• With the following steps, confirm whether [Copy of Panasonic Power Management] created when the Power Saving Utility is made has become 100 and more or not.             <ol style="list-style-type: none"> <li>1. Touch and hold  or  on the task tray and touch [Power Options].</li> <li>2. Touch [Show additional plans].</li> </ol> <p>When more than one [Copy of Panasonic Power Management] is displayed, touch [Change plan settings] in the power plan to be deleted and touch [Delete this plan] to delete.</p> </li> </ul>
<p>The screen does not become bright.</p>	<ul style="list-style-type: none"> <li>• The brightness is set low to avoid malfunction where surrounding temperature is high. For proper operating temperature (  <a href="#">Specifications</a> )</li> </ul>
<p>There are red, green, or blue dots on the screen, or there is unevenness in colors and brightness on the screen.</p>	<p>The following are not malfunctions.</p> <ul style="list-style-type: none"> <li>• Although advanced high-precision technologies are used in the production of color LCD screens, 0.002% or less of the picture elements may be dark or remain constantly lit (i.e., more than 99.998% of elements function properly).</li> <li>• Due to the natural characteristics of LCD screens, you may notice unevenness in colors and brightness depending on your angle of view. Hues may also vary by product.</li> </ul>
<p>The screen is disordered.</p>	<ul style="list-style-type: none"> <li>• Changing the number of display colors and resolution may affect the screen. Restart the computer.</li> <li>• Connecting/disconnecting an external display may affect the screen. Restart the computer.</li> <li>• Resuming from sleep or hibernation may affect the screen of the external display. Restart the computer.</li> </ul>
<p>During Simultaneous display, one of the screens becomes disordered.</p>	<ul style="list-style-type: none"> <li>• When using the Extended Desktop, use the same display colors for the external display as those used by the LCD. If you continue to experience problems, try changing the display.</li> </ul>
<p>The external display does not work normally.</p>	<ul style="list-style-type: none"> <li>• If the external display does not support the power saving function, it may not work normally when the computer enters the power saving mode. Turn off the external display.</li> <li>• Simultaneous display cannot be used until Windows startup is complete (during Setup Utility, etc.).</li> </ul>



## Sound

<p>No sound.</p>	<ul style="list-style-type: none"> <li>• Press  /  to cancel mute.</li> <li>• Turn off the concealed mode. (  <a href="#">Concealed Mode</a> )</li> <li>• Restart the computer.</li> <li>• Beeping sounds are not emitted by this device.</li> </ul>
<p>Distorted sound.</p>	<ul style="list-style-type: none"> <li>• Stop and restart playback.</li> </ul>
<p>Cannot record with microphone</p>	<ul style="list-style-type: none"> <li>• Use a monaural condenser microphone.</li> </ul>
<p>Cannot change the volume by pressing  / .</p>	<ul style="list-style-type: none"> <li>• Activate the Windows sound function. When it is not active, the volume does not change even if slide bar is displayed.</li> </ul>
<p>The microphone volume is small.</p>	<ul style="list-style-type: none"> <li>• Increase the volume of the microphone according to the following steps.:             <ol style="list-style-type: none"> <li>1. Touch  (Start) - [Windows System] - [Control Panel].</li> <li>2. Touch [Hardware and Sound] - [Sound] - [Recording] - [Microphone Array] - [Properties], and then increase the volume of [Microphone Array] and/or [Microphone Boost] in [Levels].</li> </ol> </li> </ul>
<p>When signing in (e.g., resuming the computer), audio is distorted.</p>	<ul style="list-style-type: none"> <li>• Perform the following steps to change the audio settings to prevent audio output.             <ol style="list-style-type: none"> <li>1. Touch and hold  (Speaker) on the task tray, and touch [Sounds].</li> <li>2. Remove the check mark from [Play Windows Startup sound].</li> </ol> </li> </ul>
<p>The feedback noise may occur.</p>	<ul style="list-style-type: none"> <li>• To stop microphone's monitoring output.             <ol style="list-style-type: none"> <li>1. Touch  (Start) - [Windows System] - [Control Panel].</li> <li>2. Touch [Hardware and Sound] - [Sound] - [Recording] - [Microphone Array] - [Properties], and then remove a check mark for [Listen to this device] in [Listen].</li> </ol> </li> </ul>

## Input Characters



<p>Cannot enter special characters (ß, à, ç, etc.) and symbols.</p>	<ul style="list-style-type: none"> <li>• Use the character map.             <ol style="list-style-type: none"> <li>1. Touch  (Start) - [Windows Accessories] - [Character Map].</li> <li>2. Input "Character".</li> </ol> </li> </ul>
---	--

## Network

<p>&lt;Only for model with LAN&gt; Cannot connect to a network.</p>	<ul style="list-style-type: none"> <li>• Set the device <a href="#">[Extension Port]</a> to [Enabled] in the [Advanced] menu of the Setup Utility.</li> </ul>
<p>&lt;Only when using the Cradle with LAN&gt; Cannot connect to a network.</p>	<ul style="list-style-type: none"> <li>• Set <a href="#">[Cradle USB Port]</a> to [Enabled] in the [Advanced] menu of the Setup Utility.</li> </ul>

Cannot check the computer's MAC address.

- Follow the steps below.

- Touch  (Start) -  (Settings).
- Touch [Network & Internet] - [Status] - [View your network properties].  
Properties of each device appears.  
Write down the 12-digit address (alphanumeric) that appears for "Physical address (MAC):" rows of each devices.  
The names of each of the devices are as follows.

Device	Connection name
Wireless WAN	Cellular
<Only for model with LAN> Wired LAN	Ethernet
Wireless LAN	Wi-Fi
Bluetooth	Bluetooth Network Connection



\* The content displayed will vary depending on the device and model.

- Touch  to close the window.

### Wireless Communication (only for model with wireless LAN/Bluetooth/wireless WAN)

Cannot connect to a network.

- Set the device ([Wireless LAN] / [Bluetooth] / [Wireless WAN] of [Wireless Configuration]) to [Enabled] in the [Advanced] menu of the Setup Utility (  [Wireless Configuration](#) ).
- Confirm the airplane mode is Off.  
To turn off the airplane mode, follow the steps below.

- Touch  (Start) -  (Settings) - [Network & Internet] - [Airplane mode] .
- Set "Airplane mode"\*<sup>1</sup> to [Off], and then;
  - set "Cellular" to [On] (for wireless WAN).
  - set "Wi-Fi"\*<sup>1</sup> to [On] (for wireless LAN).
  - set "Bluetooth" to [On] (for Bluetooth).
  - set "GPS" to [On] (for GPS on wireless WAN).
  - set "GPS/GNSS" to [On] (for dedicated GPS).

\*1

- If this computer cannot be connected to an IEEE802.11a network, confirm "[Enabling/Disabling the Wireless LAN Standard IEEE802.11a \(802.11a\)](#)".
- Restart the computer.

Access point is not detected.

- Shorten the distance between the computer and the access point, and try the detection again.
- Confirm the following settings:
  - [\[Wireless LAN\]](#) in the [Advanced] menu of the Setup Utility
    - Confirm that [\[Wireless LAN\]](#) of [Wireless Configuration] is set to [Enabled].
  - Airplane mode\*<sup>1</sup>
    - Confirm that Wireless LAN (Wi-Fi) is [On].
- This computer uses channels 1 through 13\*<sup>2</sup> when using IEEE802.11b/g/n. Check the channel being used by the access point.

<p>&lt;Only for model with wireless WAN&gt; Cannot communicate.</p>	<ul style="list-style-type: none"> <li>• Confirm the following settings: <ul style="list-style-type: none"> <li>• [Wireless WAN] in the [Advanced] menu of the Setup Utility <ul style="list-style-type: none"> <li>• Confirm that [Wireless WAN] of [Wireless Configuration] is set to [Enabled].</li> </ul> </li> <li>• Airplane mode*1 <ul style="list-style-type: none"> <li>• Confirm that Wireless WAN (Cellular) is [On].</li> </ul> </li> <li>• Confirm that the nanoSIM card is inserted correctly.</li> </ul> </li> </ul> <p>If communication is not established after proceeding with the above remedies, the wireless WAN device may not be correctly recognized. Restart the computer.</p>
---	---

\*1 : Screen messages are explained in [English (United States)].



(Depending on the language preference, some screen messages in these instructions are different from the actual screen messages. For example, [Flight mode]/[WiFi] may be displayed instead of [Airplane mode]/[Wi-Fi] in some language preference.)



\*2 : In the case of wireless communications, the frequency band being used can be divided into segments, so that different communications can be conducted on each band segment. A "Channel" refers to the individual frequency bandwidth divisions.

## Display Rotation

<p>Cannot rotate the display.</p>	<ul style="list-style-type: none"> <li>• The application program currently running may not support the image rotation. Quit the program, and then try to rotate the image. This can ameliorate the status.</li> <li>• When the automatic rotation is off, screen display does not rotate automatically.</li> </ul>
<p>The operations of screen do not match the rotation angle.</p>	<ul style="list-style-type: none"> <li>• The application program currently running may not support the image rotation. Quit the program, and then try to rotate the image. This can ameliorate the status. Change a screen setup to landscape.</li> </ul>

## Connecting Peripherals

<p>An error occurs while installing the driver.</p>	<ul style="list-style-type: none"> <li>• When you install a driver of card or peripheral device, make sure that the driver is compatible with the operating system. If it is not compatible, malfunction may occur. For information about the driver, contact the manufacturer of the peripheral device.</li> </ul>
<p>A peripheral device does not work.</p>	<ul style="list-style-type: none"> <li>• Install the driver.</li> <li>• Contact the manufacturer of the device.</li> <li>• When operation resumes from sleep or hibernation, devices such as an external mouse and cards may not function properly. In this case, restart the computer or reinitialize the device.</li> <li>• When  or  is displayed in the Device Manager, remove and insert the device. If the problem persists, restart the computer.</li> <li>• When you set [USB Port] to [Disabled] in the [Advanced] menu of the Setup Utility, USB ports of cradle are also disabled.</li> <li>• The settings of USB ports can be changed separately for the computer and the cradle (optional). In the [Advanced] menu of the Setup Utility, check both [USB Port] and [Cradle USB Port] settings.</li> <li>• The computer may not recognize the connection/removal of some devices, or may not operate normally with some devices. <ol style="list-style-type: none"> <li>1. Touch and hold  (Start) at the bottom left corner, and then touch [Device Manager].</li> <li>2. Select the device, and remove the check mark for [Allow the computer to turn off this device to save power] in [Power Management]. (This item may be unavailable for some types of devices.)</li> </ol> </li> <li>• In the case that a USB device does not work, remove the USB device and connect it again.</li> </ul>
<p>The connected mouse does not work.</p>	<ul style="list-style-type: none"> <li>• Check the mouse connection.</li> <li>• Install the driver compatible with the connected mouse.</li> </ul>

<p>You do not know the address map for IRQ, I/O port address, etc.</p>	<ul style="list-style-type: none"> <li>You can check with the following procedure.</li> </ul> <ol style="list-style-type: none"> <li>Touch and hold  (Start) at the bottom left corner, and then touch [Device Manager].</li> <li>Touch [View] - [Resources by type].</li> </ol>
<p>&lt;Only for model with Serial Port&gt; The device connected to the serial port does not work.</p>	<ul style="list-style-type: none"> <li>Check the connection.</li> <li>The device driver may not work. Refer to the instruction manual of the device.</li> <li>Set <a href="#">[Serial Port]</a> to [Auto] in the sub-menu of [Serial Port Settings] in the [Advanced] menu of the Setup Utility.</li> <li>The I/O and IRQ you can use vary depending on the device. If the setting does not work, try other settings in the Setup Utility.</li> </ul>
<p>&lt;Only for model with dedicated GPS / GPS on wireless WAN&gt; GPS does not work.</p>	<ul style="list-style-type: none"> <li>You can check the GPS status. (  <a href="#">GPS</a> )</li> <li>Set airplane mode to OFF.</li> <li>Check the airplane mode setting.</li> <li>If a USB 3.0 compatible device is used, GPS information may not be correctly received. In this case, do any of the following. <ul style="list-style-type: none"> <li>Set [SuperSpeed USB] of [USB Port] or [SuperSpeed USB] of [Cradle USB Port] to [Disabled] at the Setup Utility.</li> </ul> </li> </ul> <p>&lt;Only for model with USB 2.0 port&gt;</p> <ul style="list-style-type: none"> <li>Connect the USB device to the USB 2.0 port.</li> <li>Use an extension cable (separately sold) compatible with USB 2.0.</li> <li>If an external antenna for GPS can be used, use the external antenna, and keep some distance between the external antenna and the USB device.</li> </ul>

## Screen Operation

<p>Cannot operate the touchscreen.</p>	<ul style="list-style-type: none"> <li>If the screen is wet with water drops, wipe them off.</li> <li>When using this computer in the state where the screen is wet, wipe water drops. Then turn the computer on, set touch panel mode to [Touch (Water)] in "<a href="#">Touch Screen Mode</a>".</li> <li>Before the computer turn on, wipe water drops.</li> </ul>
<p>The pointer does not work.</p>	<ul style="list-style-type: none"> <li>If the computer does not respond to keyboard commands, read "<a href="#">No response.</a>"</li> </ul>
<p>Cannot point the correct position using fingers or the digitizer pen (included).</p>	<ul style="list-style-type: none"> <li>Perform the <a href="#">Calibrating the Screen</a>.</li> <li>When using a pen, please use the digitizer pen (included).</li> <li>You may not be able to point to the correct position on the Windows sign in screen when using the pen (included). In such cases, use your fingers to sign in.</li> </ul>

## microSD Memory Card

<p>Cannot use a microSD Memory Card.</p>	<ul style="list-style-type: none"> <li>Set <a href="#">[microSD Slot]</a> to [Enabled] in the [Advanced] menu of the Setup Utility.</li> <li>This computer does not support the maximum speed some types of microSD/-microSDHC/microSDXC Memory Cards guarantee.</li> </ul>
--	---

## Smart Card (only for model with Smart Card slot)

<p>Cannot use a Smart Card.</p>	<ul style="list-style-type: none"> <li>Insert the Smart Card correctly.</li> <li>Set <a href="#">[Extension Port]</a> to [Enabled] in the [Advanced] menu of the Setup Utility.</li> <li>To use a Smart Card, you need a specified software and driver.</li> </ul>
---------------------------------	--





## Barcode Reader (only for model with Barcode Reader)

Reading is not possible.	<ul style="list-style-type: none"><li>• Confirm that the barcode is readable (without damage, etc.). Confirm that the barcode (symbol) is readable. If the barcode is Codablock A or ISBN, for example, configure the code so that it is readable using the Barcode Configuration Utility.</li><li>• Confirm the area for reading. The distance from the reader to the barcode is important. As a rule of thumb, a farther distance should be used for a larger symbol to allow the light to cover the symbol. In addition, a closer distance should be used for a thinner symbol.</li><li>• Be sure the barcode is not placed closer than necessary to the reader.</li><li>• Set [Extension Port] to [Enabled] in the [Advanced] menu of the Setup Utility.</li></ul>
--------------------------	--

## User Switching

Some applications do not work properly.	<ul style="list-style-type: none"><li>• When switching to a different user without signing out, some applications do not work properly. In this case, sign out the other users.</li></ul>
---	---

## Others

Although the computer is turned on, the following problems occur. <ul style="list-style-type: none"><li>• The indicators do not light.</li><li>• No sound.</li><li>• Screen is dark.</li></ul>	<ul style="list-style-type: none"><li>• The concealed mode is enabled (  <a href="#">Concealed Mode</a> ).</li></ul>
No response.	<ul style="list-style-type: none"><li>• Open Task Manager and close the software application.<ol style="list-style-type: none"><li>1. Touch and hold  (Start) at the bottom left corner, and then touch [Task Manager].</li></ol></li><li>• An input screen (e.g., password input screen at startup) may be hidden behind another window. Touch the button on the task bar to check.</li><li>• Shut down by pressing and holding the power switch  for 4 seconds or longer, and turn on the computer and open the application again.</li><li>• If Windows runs correctly, but the application software does not start, uninstall the failing application software, then reinstall it. To uninstall, perform the procedure below.<ol style="list-style-type: none"><li>1. Touch  (Start) -  (Settings) - [Apps] - [Apps &amp; features].</li><li>2. Select the program you want to uninstall, and touch [Uninstall].</li></ol></li></ul>
A motion image file cannot be played using Windows® Media Player and the message “Codec required” appears.	Some motion image files require a Codec that is not installed as standard. In this case, connect to the Internet and try playback of the file again. The Codec may automatically be downloaded so you may be able to play it.
“Battery not exist” is displayed.	Battery goes to sleep if the battery is about 5%, may be displayed such as “Not exist” or “Not use” is not a malfunction. Connect the AC adaptor for a while.

## Checking the Computer's Usage Status

You can check the computer's usage status in the PC Information Viewer. You may need this information when calling Panasonic Technical Support for advice.

### NOTE

- This computer periodically records the management information of the flash memory, etc. The maximum data volume for each record





is 1024 bytes. The information is only used for estimating the cause when the flash memory goes down by any possibility. They are never sent to outside via network nor used for any other purpose except for the purpose described the above.

To disable the function, add the check mark for [Disable the automatic save function for management information history] in [Hard Disk Status] of PC Information Viewer, and touch [OK].

- A standard user needs to enter an administrator password.

- Depending on your network environment, it may take 1 minute to start up the PC Information Viewer .

## Launching PC Information Viewer

1. Touch  (Start) -  (Panasonic PC Settings Utility) -  (Support) -  (System) - [Launch PC Information Viewer].
2. Select the item to display the detailed information.

### To save the information as a text file

1. Display the information you wish to save.
2. Touch [Save].
  - To save the item that is displayed  
Touch [Save only the information displayed] and touch [OK]. Some of the hidden information on the screen, which cannot be shown without scrolling the screen, will be saved, too.
  - To save all items  
Touch [Save all the information] and touch [OK].

In the case of [Hard Disk Status], if you do not add the check mark for [Disable the automatic save function for management information history], the records already recorded are also saved.

3. Select the folder to save the information, input the file name, and then touch [Save].

### To save a copy of the screen as an image file

To save a copy of the screen as an image file, perform the following steps.

1. Display the screen you want to save.



2. Press

The screen image is saved in "Screenshots" folder under "Pictures" folder.

## Hardware Diagnostics

If it appears that the hardware installed in this computer is not operating properly, you can use the PC-Diagnostic Utility to determine whether or not there is a problem.

If the utility discovers a problem in the hardware, contact Panasonic Technical Support.

Software cannot be checked using this utility.

### Preparation

- Connect an external keyboard and an external mouse to the computer.

## NOTE

- When you start the PC-Diagnostic Utility without connecting an external keyboard and an external mouse, shut down the computer by pressing and holding the power switch. Then, connect an external keyboard and an external mouse to the computer and restart the PC-Diagnostic Utility.

## Hardware that can be checked using the PC-Diagnostic Utility



- CPU/System
- RAM XXXX MB
- Storage XXX GB
- Sound\*1
- USB
- SD (Only for model with microSD Card Slot)
- Touch Screen
- Wireless LAN (Only for model with wireless LAN)
- Video
- Serial Port (Only for model with serial port)
- Wireless WAN (Only for model with wireless WAN)
- Bluetooth (Only for model with Bluetooth)
- GPS (Only for model with dedicated GPS)

\*1 : When the PC-Diagnostic Utility is running a loud beep will sound, so do not use headphones as this time. (The beep will not sound if mute is using in Windows or [Sound] is turned off in [Concealed Mode Configuration].)

## NOTE

- When the video diagnostic check is running, the display may be distorted. This is not malfunction.

## Regarding the PC-Diagnostic Utility

Operations	Touch screen / External mouse operations	External keyboard operations
Select icon	Place the cursor above the icon	Press « → » « ← » « ↑ » « ↓ » (  (close) cannot be selected)
Touch the icon	Touch or click (Right-click cannot be used)	Press « Space » above the icon
Complete the PC-Diagnostic Utility and then restart the computer	Touch or click  (close)	Press « Ctrl » + « Alt » + « Del »

## Running the Diagnostic Check



Run this utility using the default settings in the Setup Utility.

If the Setup Utility or other settings will not allow hardware to be executed, the hardware icon will be displayed in gray.

1. **Connect the AC adaptor, and then connect external keyboard or mouse.**

During the diagnostic check, do not remove the AC adaptor, or attach any peripheral devices.

2. **Start the Setup Utility.**

1. Touch  (Start) -  (Settings) - [Update & Security] - [Recovery].
2. Touch [Restart now] under "Advanced startup".\*2
3. Touch [Troubleshoot] - [Advanced options] - [UEFI Firmware Settings] - [Restart].  
The computer restarts, and the Setup Utility screen appears.
  - If the password is requested, enter the Supervisor Password.
  - If you are using the computer after changing the settings from the status at the time of purchase, we recommend that you make a note of the settings that are changed.

\*2 : Screen messages are explained in [English (United States)].

(Depending on the language preference, some screen messages in these instructions are different from the actual screen messages. For example, [Advanced start-up] may be displayed instead of [Advanced startup] in some language preference.)

3. **Touch [Exit] menu, then double-touch [Load Default Values].**

At the confirmation message, touch [Yes].

4. **Touch [Exit] menu, then double-touch [Save Values and Reboot].**

At the confirmation message, touch [Yes].

The computer will restart.





5. **Touch the top left corner of the screen several times to display Setup Utility.**

6. **Touch [Exit] menu, and then double-touch [Diagnostic Utility].**

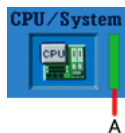
When the PC-Diagnostic Utility starts up, it will automatically begin the diagnostic check for all hardware components.

- If the password is requested, enter the password.
- The keyboard may not be used when each hardware checking is running. While checking, a vertical green progress bar (A) is displayed on the right side of the hardware icon.



- You can perform the following operations by touching the icons on the screen:
  -  : Start the diagnostic check from the beginning.
  -  : Stop the diagnostic check (After the process is stopped, you cannot resume it by touching ).
  -  : Display help (Touch the screen to return to the original screen.).
- You can check the status and results of the diagnostic check via the progress bar displayed on the right of the hardware icon.
  - When the bar is progressing: The diagnostic check is in progress.  
During memory diagnostic check, the display may stop for a long period of time. Wait until the process is complete.
  - When the bar is green: No problems discovered.
  - When the bar is red: Problems discovered.
  - When the bar is yellow: The diagnostic check has been stopped or is complete.

### NOTE

- Using the following procedure, you can run a diagnostic check on a specified hardware component, or run an extended diagnostic check on the memory or the flash memory (The extended diagnostic check is only for the memory and the flash memory). The extended diagnostic check is more detailed, and so requires a longer period of time to run.



- 
1. Touch  to stop the diagnostic check, and touch the hardware icon to configure the diagnostic.

- Standard display (B): Perform diagnostic check.

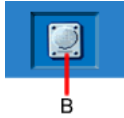

- "FULL" display (C): Perform extended diagnostic check. ("Storage" and "Touch Screen" only)



- Gray display (D): Do not perform diagnostic check.

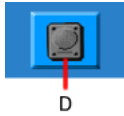

2. Touch  to start the diagnostic check.

- Display during diagnostic check (E): Diagnostic check is in progress.

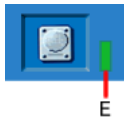

- 
7. **When all the hardware has been checked, confirm the diagnostic check results.**

If the display is red and the message "TEST FAILED" is displayed, you can assume that there is a problem with the computer's hardware. Confirm which hardware component is displayed as red, and contact Panasonic Technical Support.

If the display is green and the message "TEST PASSED" is displayed, the computer's hardware is operating normally. Continue using the computer as it is. If the computer still does not operate properly, reinstall the software (  [Installing Software](#) ).

8. After the diagnostic check is complete, touch  (close) to restart the computer.

---

## When the Icon Becomes Gray and the Corresponding Device Cannot Be Checked

---



- **The device is disabled in the Setup Utility:**  
Set the device to [Enabled] in the Setup Utility.

## Reset your computer

If operations on the unit become unstable, we recommend refreshing Windows. This involves reinstalling the operating system while retaining personal files and settings (Personalization).

### Preparation

- Remove all peripherals and microSD memory card, etc.
- Connect the AC adaptor and do not remove it until installation is complete.

1. Touch  (Start) -  (Settings) - [Update & Security] - [Recovery].
2. Touch [Get started] under "Reset this PC".
3. Select the option.
  1. [Keep my files]  
Windows reinstallation can be completed in a short time (Approximately 30 minutes). Applications and other items that do not come with this computer will be removed.
  2. [Remove everything]  
Select [Yes] or [No] under the "Keep this PC set up for your workplace".
    - [Just remove my files] (Approximately 30 minutes)
    - [Remove files and clean the drive]  
By fully cleaning, the deleted files cannot be recovered easily and the security level will be increased. The processing time will be longer (Approximately 50 minutes).
4. Follow the on-screen instructions.  
After the reinstallation, the computer will restart.
  - Do not interrupt installation, for example by turning off the computer or performing other operation. Otherwise installation may become unavailable as Windows may not start up or the data may be corrupted.
5. Perform Setup Windows (  **OPERATING INSTRUCTIONS - Read Me First** ).

### NOTE

- The date and time, and the time zone may not be correct. Be sure to set them correctly.

6. Perform Windows Update.
7. <Only for model with TPM> Clear TPM.
  1. Touch and hold  (Start) at the bottom left corner.
  2. Touch [Run], then input "tpm.msc" and touch [OK].
  3. Touch [Clear TPM] under "Actions" on the right of the "Trusted Platform Module (TPM) Management on Local Computer" screen.
  4. Touch [Restart] of the "Manage the TPM security hardware" screen.  
TPM is cleared, and the computer will restart.

## Installing Software

Installing software will return the computer to the default condition. When you install the software, the internal SSD data will be erased.

Back up important data to other media or an external flash memory before installation.

- **Do not delete the recovery partition on the SSD. If it has been deleted, the recovery disc could not be created.**

To check the recovery partition, perform the following methods.



1. Touch and hold (Start) at the bottom left corner, and touch [Disk Management].

- A standard user needs to enter an administrator password.

## Disk recovery

You can reinstall the OS that was pre-installed at the time of purchase.

- **If the recovery partition is deleted, you cannot perform flash memory recovery.**

If reinstallation using the method described in “Reset this PC” is not successful, follow the steps below.

### Preparation

- Remove all peripherals and microSD memory card etc.
- Connect the AC adaptor and do not remove it until installation is complete.

#### 1. Start the Setup Utility.



1. Touch (Start) - (Settings) - [Update & Security] - [Recovery].
2. Touch [Restart now] under “Advanced startup”.
3. Touch [Troubleshoot] - [Advanced options] - [UEFI Firmware Settings] - [Restart].

#### 2. Write down all of the contents of the Setup Utility.

#### 3. Touch [Exit] menu, and then double-touch [Load Default Values].

At the confirmation message, touch [Yes].

#### 4. Touch [Exit] menu, and then double-touch [Save Values and Reboot].

At the confirmation message, touch [Yes].

Computer will restart.

#### 5. Touch the top left corner of the screen several times while “Panasonic” boot screen is displayed.

The Setup Utility starts up.

- If the password is requested, enter the Supervisor Password.

#### 6. Touch [Exit] menu, and then double-touch [Recovery Partition].

Computer will restart.

#### 7. Touch [Recovery]

Touch [CANCEL] to abort the operation.

#### 8. Confirm the contents of “EULA”, and touch [Accept] if you continue.

#### 9. Touch [Disk 0].

#### 10. Touch [Recovery ALL Partitions.].

Installation starts according to the instructions on the screen. (It will take approximately several tens of minutes.)

- Do not interrupt installation, for example by turning off the computer or performing other operation. Otherwise installation may become unavailable as Windows may not start up or the data may be corrupted.
11. **When the Ending process screen is displayed, touch [Shutdown.] to turn off the computer.**
  12. **Turn on the computer.**
    - If the password is requested, enter the Supervisor Password.
  13. **Perform Setup Windows (  *OPERATING INSTRUCTIONS - Read Me First*).**
  14. **Start the Setup Utility and change the settings as necessary.**
  15. **<Only for model with TPM> Clear TPM.**



1. Touch and hold  (Start) at the bottom left corner.
2. Touch [Run], then input “tpm.msc” and touch [OK].
3. Touch [Clear TPM] under “Actions” on the right of the “Trusted Platform Module (TPM) Management on Local Computer” screen.
4. Touch [Restart] of the “Manage the TPM security hardware” screen.  
TPM is cleared, and the computer will restart.

---

## Using Recovery Disc

---



Use the Recovery Disc in the following conditions.

- You have forgotten the administrator password.
- Installation is not complete. The recovery partition in the flash memory may be broken.

### Preparation

- Prepare the following items:
  - Recovery Disc (  [Create a Recovery Disc](#) )
  - When using DVD media to create a recovery disc, prepare the commercially available optical drive.
- Remove all peripherals (excluding the device that was used to create the recovery disc).
- Connect the AC adaptor and do not remove it until installation is complete.

### 1. Start the Setup Utility.

1. Touch  (Start) -  (Settings) - [Update & Security] - [Recovery].
2. Touch [Restart now] under “Advanced startup”.
3. Touch [Troubleshoot] - [Advanced options] - [UEFI Firmware Settings] - [Restart].

### 2. Write down all of the contents of the Setup Utility.

### 3. Touch [Exit] menu, and then double-touch [Load Default Values].

At the confirmation message, touch [Yes].

### 4. Insert the media that was used to create the recovery disc.

- For DVD media
  1. Connect the commercially available optical drive to the USB Port.
  2. Insert the recovery disc into the commercially available optical drive.
- For USB storage devices
  1. Connect the USB storage device used to create the recovery disc to the USB port.

### 5. Touch [Exit] menu, and then double-touch [Save Values and Reboot].

At the confirmation message, touch [Yes]. Computer will restart.

### 6. Touch the top left corner of the screen several times while “Panasonic” boot screen is displayed.

The Setup Utility starts up.

- If the password is requested, enter the Supervisor Password.

### 7. Touch [Exit] menu, and then double-touch your commercially available optical drive or USB storage device in “Boot Override”.

The computer will restart.

8. Touch [Recovery].
9. At the confirmation message, touch [Accept].
10. Confirm the contents of "EULA", and touch [Accept] if you continue.
11. Touch [Disk 0].
12. Touch [Recovery ALL Partitions.].
13. Touch [Remain Recovery Partition.].  
Follow the on-screen instructions.
14. When the Ending process screen is displayed, remove the Recovery Disc and commercially available optical drive and then touch [Reboot].  
Follow the on-screen instructions.
15. On the "Finish Recovery Process." screen, touch [Shutdown.].
16. Turn on the computer.
17. Perform Setup Windows ( → *OPERATING INSTRUCTIONS - Read Me First*).
18. Start the Setup Utility and change the settings as necessary.
19. <Only for model with TPM> Clear TPM.



1. Touch and hold  (Start) at the bottom left corner.
2. Touch [Run], then input "tpm.msc" and touch [OK].
3. Touch [Clear TPM] under "Actions" on the right of the "Trusted Platform Module (TPM) Management on Local Computer" screen.
4. Touch [Restart] of the "Manage the TPM security hardware" screen.  
TPM is cleared, and the computer will restart.

## Error Message

Follow the instructions below when an error message appears. If the problem persists or if the error message is not shown here, contact Panasonic Technical Support.

Error Message	Solution
Bad System CMOS	<p>An error has occurred in the memory of system settings. This occurs when the memory content is changed by an unexpected program operation, etc.</p> <ul style="list-style-type: none"> <li>Start the Setup Utility and return the settings to the default values, and then change the settings as necessary.</li> <li>If the problem persists, the internal clock battery may need to be replaced. Contact Panasonic Technical Support.</li> </ul>
System CMOS Checksum Error	
Invalid Year. System date restored to 01/01/20XX	<p>The date and time settings are not correct.</p> <ul style="list-style-type: none"> <li>Start the Setup Utility and set the correct date and time.</li> <li>If the problem persists, the internal clock battery may need to be replaced. Contact Panasonic Technical Support.</li> </ul>
Press F2 for Setup	<ul style="list-style-type: none"> <li>Write down the error details and start the Setup Utility. Change the settings if necessary.</li> </ul>
Warming up the system (up to 30 minutes)	<p>The computer is warming up before start up. Wait for the computer to start up (takes up to 30 minutes). If, "Cannot warm up the system" is displayed, the computer failed to warm up and does not start. In this case, turn off the computer, leave it in an environment of 5 °C {41 °F} or higher temperature for about an hour, and then turn on the power once more.</p>
Remove disks or other media. Press any key to restart	<ul style="list-style-type: none"> <li>If a device is connected to the USB port, disconnect the device, or set [USB Port] to [Disabled] in the [Advanced] menu of the Setup Utility.</li> <li>If the problem persists after removing the disk, it may be a flash memory failure. Contact Panasonic Technical Support.</li> </ul>
Reboot and Select proper Boot device or Insert Boot Media in selected Boot device and press a key	<p>The operating system is not properly installed in the flash memory that you are going to boot from.</p> <ul style="list-style-type: none"> <li>If you cannot start up the OS from the internal disk, check if the internal disk is properly recognized on the [Information] menu of the Setup Utility.</li> <li>If it is recognized ("xxx GB" is displayed.), perform the reinstallation.</li> <li>If not ("Empty" is displayed.), contact Panasonic Technical Support.</li> <li>If a device is connected to the USB port, remove the device, or set [Legacy USB Support] to [Disabled] on the "Advanced" menu of the Setup Utility.</li> </ul>
Disk error Press any key to restart	
Please use the recommended AC adaptor	<ul style="list-style-type: none"> <li>Use the specified AC adaptor.</li> </ul>

### Network Connections and Communications Software



Close the communications software before using the power saving function.

- If the power saving function (sleep or hibernation) is activated while communications software is used, the network connection may be interrupted, or the performance may be adversely affected. In this case, restart the computer.
- In a network environment, set [Never] for [Sleep after] and [Hibernate after] (  [Setting Sleep or Hibernation](#)).

### About Fast startup

The fast startup is enabled as the factory default.



If the computer shut down by the following steps, the fast startup will be disabled at next boot-up.

1. Touch  (Start) -  (Settings) - [Update & Security] - [Recovery].
2. Touch [Restart now] under "Advanced startup"\*1.
3. Touch [Turn off your PC].

\*1 : Screen messages are explained in [English (United States)].

(Depending on the language preference, some screen messages in these instructions are different from the actual screen messages. For example, [Advanced start-up] may be displayed instead of [Advanced startup] in some language preference.)

If you perform the following steps, the fast startup function becomes always disabled.

1. Touch  (Start) -  (Settings) - [System] - [Power & sleep] - [Additional power settings] - [Choose what the power button does].
2. Touch [Change settings that are currently unavailable].
3. Remove checkmark from [Turn on fast startup (recommended)] in "Shutdown settings".

### Serial Devices

The COM ports of the computer are assigned as below.

- COM1 : Serial Port\*2
- COM2 : Barcode Reader\*2

\*2 : Optional

If you change the assignment, the serial devices may not work properly.

## Erasing Flash Memory Data

When disposing the computer or transferring the ownership, erase all flash memory drive data in order to avoid data leakage. Even if you erase the data or initialize the flash memory drive using normal Windows commands, the data can be read with some special software. Use the flash memory drive data erase function to erase the data completely.

Note that transferring of the ownership without uninstalling the commercial software will be a violation of the software's license agreement.

## Erasing Flash Memory Data

The flash memory drive data erase function erases data using an overwriting method, but there is a possibility that due to malfunctions or other operational errors, data may not be completely erased. There are also specialized devices that may be able to read data that has been erased using this method. If you need to erase highly confidential data, we recommend that you contact a company that specializes in this process. Panasonic Corporation will bear no responsibility for losses or damages suffered as a result of the use of this function.

- Connect the AC adaptor and do not remove it until flash memory data erase is complete.

## NOTE



- This function cannot be used to erase the data on the specified partition. However, the entire flash memory drive data including the data of the partition with recovery tools will be erased.
- The erasing disk menu is not displayed when using the recovery partition.

## Using Recovery Disc

### Preparation

- Recovery Disc (  [Create a Recovery Disc](#) )
- When using DVD media to create a recovery disc, prepare the commercially available optical drive.
- Connect the AC adaptor and do not remove it until flash memory drive data erase is complete.

#### 1. Start the Setup Utility.

1. Touch  (Start) -  (Settings) - [Update & Security] - [Recovery].
2. Touch [Restart now] under "Advanced startup".
3. Touch [Troubleshoot] - [Advanced options] - [UEFI Firmware Settings] - [Restart].

#### 2. Write down all of the contents of the Setup Utility.

#### 3. Touch [Exit] menu, and then double-touch [Load Default Values].

At the confirmation message, touch [Yes].

#### 4. Insert the media that was used to create the recovery disc.

- For DVD media
  1. Connect the commercially available optical drive to the USB Port.
  2. Insert the recovery disc into the commercially available optical drive.
- For USB storage devices
  1. Connect the USB storage device used to create the recovery disc to the USB port.

#### 5. Touch [Exit] menu, and then double-touch [Save Values and Reboot].

At the confirmation message, touch [Yes].

Computer will restart.

#### 6. Touch the top left corner of the screen several times while "Panasonic" boot screen is displayed.

The Setup Utility starts up.



- If the password is requested, enter the Supervisor Password.
7. **Touch [Exit] menu, and then double-touch the commercially available optical drive or USB storage device in "Boot Override" .**  
The computer will restart.
  8. **Touch [Erase].**
  9. **Touch [Erase the all data on the whole Disk.].**
  10. **Touch [Start Erase Process.].**  
Erasing the flash memory drive data starts.
  11. **After the erasing is completed, remove the Recovery Disc and touch [Shutdown.].**

## Dispose of Computer

<Only for model with Built-in Bridge Battery>

<For Europe and U.S.A./Canada>

### Attention Customers

Don't remove the battery by yourself. The battery must be removed by qualified professionals. When disposing of this product, be sure to contact qualified professionals to remove the battery.

### Attention Qualified professionals to remove the battery

Dispose of this product correctly in accordance with the local regulations after removing the battery as shown in the following procedure.

#### Preparation

- Remove all peripherals and microSD memory card, etc.
- Erase the stored data. ( → [Erasing Flash Memory Data](#))

- 
- Never disassemble the computer except before disposal.
  - Refer to *OPERATING INSTRUCTIONS - Read Me First* "Safety Precautions" for precautions when disposing of the computer.
- 

1. Turn off the computer, and disconnect the AC adaptor.
2. Turn over the computer, remove the battery pack, and wait for about 1 minute.
3. If there are a hand strap, open up the whole hand strap.
  1. Remove the edge (A) of hand strap passing through the clip. (The illustration shows the top side of hand strap as an example.)

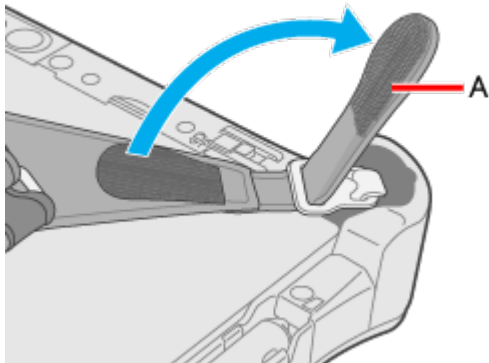

2. Tip the clip (B) back to pull it out of the computer. (Do the same for the bottom side of hand strap.)

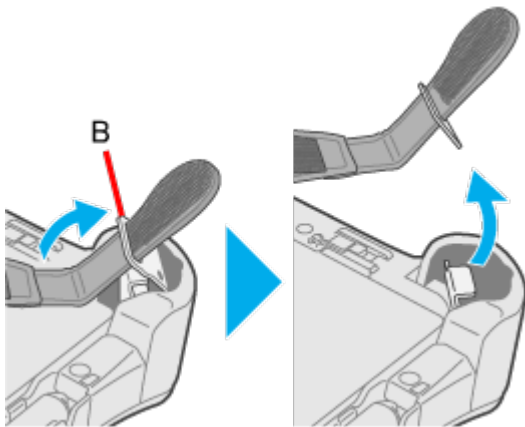

3. Open up the whole hand strap.

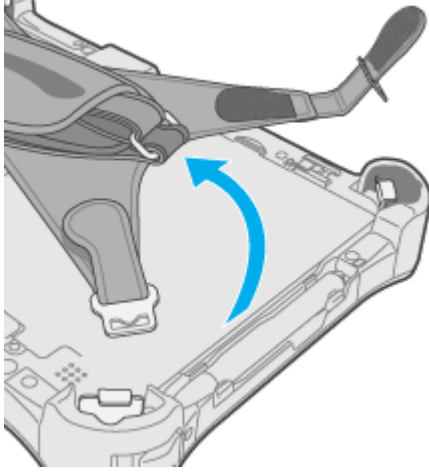

4. Remove the screws (4) and turn over the cover (C).

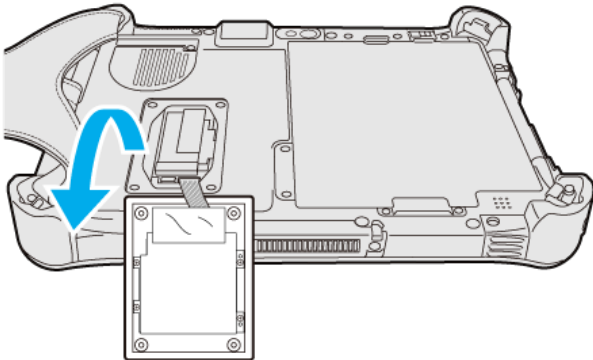
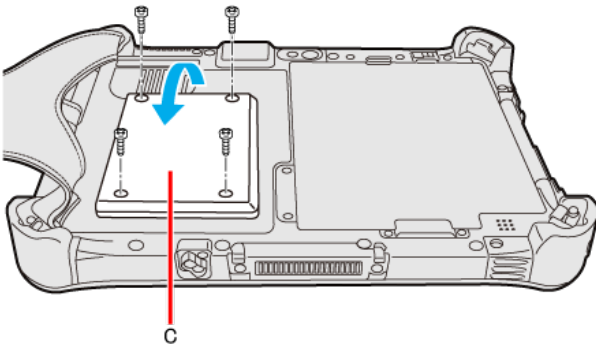

5. Pull back the sheets (D) in the cover, and then remove the black screws (4).

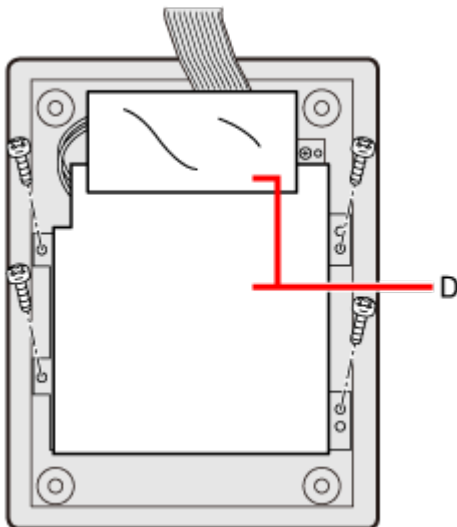

6. Remove the connector of the built-in bridge battery (E), and remove the built-in bridge battery with the metal plate (F).

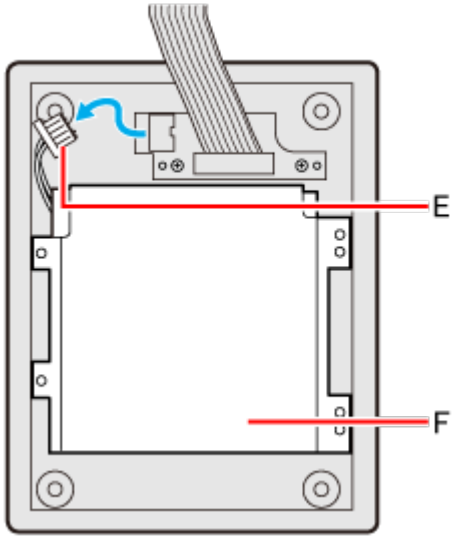

Insulate the connector of the built-in bridge battery by covering them with plastic tape, for example.

## Specifications

This page provides the specifications for the basic model.

The model number is different according to the unit configuration.

**To check CPU speed, memory size and the flash memory drive (SSD) size:**



Run the Setup Utility (  [Setup Utility](#) ) and select "Information" menu.

[Processor Speed]: CPU speed, [Memory Size]: Memory size, [Hard Disk]: SSD size

**To check the model number:**

(  [The model number is described on the computer](#) )

## Main Specifications

CPU	Intel® Core™ i5-7300U vPro™ Processor (3 MB <sup>*1</sup> cache, 2.6 GHz up to 3.5 GHz with Intel® Turbo Boost Technology)	
Chip Set	Built-in CPU	
Video controller	Intel® HD Graphics 620 (Built-in CPU)	
Main Memory <sup>*1*2</sup>	4 GB / 8 GB	
Storage <sup>*3</sup>	128 GB / 256 GB / 512 GB / 1 TB (SSD) Approx. 10 GB is used as a partition with disk recovery tools. (Users cannot use this partition.) Approx. 1 GB is used as a partition with system tools. (Users cannot use this partition.)	
Display Method	10.1 WUXGA (1920 × 1200), Aspect ratio 16:10	
	Internal LCD <sup>*4</sup>	65,536 / 16,777,216 colors (1920 × 1200)
	External Display (HDMI) <sup>*5</sup>	65,536 / 16,777,216 colors (1920 × 1200 Max.)
Wireless LAN <sup>*6</sup>	Intel® Dual Band Wireless-AC 8265 (  <a href="#">Wireless LAN</a> )	
Bluetooth <sup>*7</sup>	(  <a href="#">Bluetooth</a> )	
Sound	WAVE and MIDI playback, Intel® High Definition Audio subsystem support, Monaural speaker	
Security Chip	TPM (TCG V2.0 compliant)	
Camera	Front	2 MP (1920 × 1080 pixels), 30 fps (Video), Monaural Microphone
	Rear <sup>*8</sup>	8 MP (1280 × 720 pixels), 30 fps (Video) / 3264 × 2448 pixels (Still), LED Flash
Sensor	Acceleration sensor	Equipped
	Digital compass	Equipped
	Gyro sensor	Equipped
	Ambient light sensor	Equipped
Interface	USB 3.0 port × 1 <sup>*9</sup> / HDMI Type A port <sup>*10</sup> / Expansion Bus Connector / 3.5mm Headset jack, Stereo Headphone: 4mW/ch (32Ω, 1kHz), CTIA Monaural Microphone	

Pointing Device	10 Finger touch (Capacitive) / Digitizer pen (Water Proof) Dual Touch (Digitizer + Touch Screen) Touch Screen :Capacitive, Anti-Reflection, touch capable Glove / Water Mode Digitizer pen included	
Power Supply	AC adaptor or Battery pack	
AC Adaptor <sup>*11</sup>	<CF-AA6413A> Input: 100 V - 240 V AC, 50 Hz/60 Hz, Output: 16 V DC, 4.06 A <CF-AA5713A> Input: 100 V - 240 V AC, 50 Hz/60 Hz, Output: 15.6 V DC, 7.05 A	
Battery Pack	Li-ion 11.1 V, 4200 mAh (typ.), 4080 mAh (min.) (with FZ-VZSU84A series) Li-ion 10.8 V, 9300 mAh (typ.), 8700 mAh (min.) (with FZ-VZSU88U (Optional))	
	Operating Time <sup>*12</sup>	Approx. 11 hours (with FZ-VZSU84A series) Approx. 22 hours (with FZ-VZSU88U (Optional))
	Charging Time <sup>*13</sup>	When using FZ-VZSU84A series <Power Off> Approx. 2.5 hours <Power On> Approx. 3 hours  When using FZ-VZSU88U (Optional) <Power Off> Approx. 3 hours <Power On> Approx. 4 hours
Power Consumption <sup>*14</sup>	Approx. 30 W <sup>*15</sup> / Approx. 60 W (maximum when recharging in the ON state)	
Physical Dimensions (W × D × H) <sup>*16</sup>	270 mm × 188 mm × 19 mm {10.6" × 7.4" × 0.75"} (without protruding parts)	
Weight <sup>*16</sup>	Approx. 1.1 kg {2.43 lbs.} (with FZ-VZSU84A series) Approx. 1.3 kg {2.87 lbs.} (with FZ-VZSU88U)	
Environment	Operating Temperature	- 10 °C to 50 °C {14 °F to 122 °F} (IEC60068-2-1, 2) <sup>*17*18</sup>
	Operating Humidity	30 % to 80 % RH (No condensation)
	Storage Temperature	- 20 °C to 60 °C {-4 °F to 140 °F}
	Storage Humidity	30 % to 90 % RH (No condensation)

## Software

Operating System <sup>*19</sup>	Windows 10 Pro 64-bit
Pre-installed Software	<ul style="list-style-type: none"> <li>• PC Information Viewer</li> <li>• Panasonic PC Recovery Disc Creation Utility</li> <li>• Intel® PROSet/Wireless Software</li> <li>• Microsoft Office Trial<sup>*20</sup></li> <li>• Wireless Manager Mobile Edition<sup>*21*22</sup></li> <li>• Emergency notification setting</li> <li>• Barcode Integrated Utility (It includes Barcode Configuration Utility / 2D Barcode Key Emulator)<sup>*21*23</sup></li> <li>• Panasonic PC Camera Utility</li> <li>• Panasonic PC GPS Viewer<sup>*24</sup></li> <li>• Panasonic PC Manual Selector</li> <li>• Panasonic PC Settings Utility<sup>*25</sup></li> <li>• Panasonic PC Thermal Viewer<sup>*26</sup></li> </ul>
	<ul style="list-style-type: none"> <li>• Aptio Setup Utility</li> <li>• PC-Diagnostic Utility</li> <li>• Hard Disk Data Erase Utility<sup>*27</sup></li> </ul>

## Wireless LAN\*6



Data Transfer Rates*28	IEEE802.11a : 54 Mbps IEEE802.11b : 11 Mbps IEEE802.11g : 54 Mbps IEEE802.11n*29 : HT20 = 144.4 Mbps HT40 = 300 Mbps IEEE802.11ac : VHT20 : 173.3 Mbps VHT40 : 400 Mbps VHT80 : 866.7 Mbps
Standard Supported	IEEE802.11a / IEEE802.11b / IEEE802.11g / IEEE802.11n / IEEE802.11ac
Transmission Method	OFDM system, DSSS system

## Bluetooth\*7

Bluetooth	Bluetooth Ver.4.2
	Classic mode / Low Energy mode
Transmission Method	FHSS system
Wireless Channels Used	Channels 0 to 78 / Channels 0 to 39
RF Frequency Band	2.402 GHz - 2.480 GHz

## Optional Devices

Camera with IR sensor	2 MP w/ stereo microphone/ALS/IR
Wireless WAN*30	LTE compatible
microSD Memory Card Slot*31	microSDXC, UHS-I
nanoSIM Card Slot	× 1
Smart Card Slot	× 1, ISO-7816
USB 2.0 port*9	× 1
LAN	× 1, IEEE 802.3 10Base-T / IEEE 802.3u 100Base-TX / IEEE 802.3ab 1000Base-T
True Serial Port*32	× 1, Dsub 9-pin male
Barcode Reader	× 1
Magnetic Stripe Card Reader	× 1, ISO-7810 and ISO-7811 / AAMVA
Contactless Smart Card Reader/RFID Reader	× 1, RF frequency: 13.56 MHz, compatible with ISO-14443 Type-A, ISO-14443 Type-B
Contactless Smart Card Reader (HF band)	× 1
UHF RFID Reader	× 1, ISO-18000-6c
Dual Pass Through Antenna	× 1
Dedicated GPS*33	Chip: u-blox NEO-M8N GPS/GLONASS/SBAS Support, USB IF
Battery Hot Swap	Built-in bridge battery (not replaceable)
Thermography Camera	× 1, FLIR® Lepton 3.5

- \*1: 1 MB = 1,048,576 bytes / 1 GB = 1,073,741,824 bytes
- \*2: Memory size of the factory default depends on the model.
- \*3: 1 MB = 1,000,000 bytes / 1 GB = 1,000,000,000 bytes. Your operating system or some application software will report as fewer GB.
- \*4: A 16,777,216 color display is achieved by using the dithering function.
- \*5: Selectable resolution depends on the specifications of the external display. Display may be impossible using some connected external displays.
- \*6: Only for model with wireless LAN.
- \*7: Only for model with Bluetooth. Does not guarantee operation of all Bluetooth peripherals.
- \*8: The specifications may differ depending on the model.  
Depending on the specification of application software, the following cases may occur. In these cases, select a smaller resolution.
  - Cannot select a large resolution.
  - When selecting a large resolution, an error occurs.
- \*9: Does not guarantee operation of all USB-compatible peripherals.
- \*10: Does not guarantee operation of all HDMI-compatible peripherals.
- \*11: <Only for North America>  
The AC adaptor is compatible with power sources up to 240 V AC adaptor. This computer is supplied with a 125 V AC compatible AC cord.
- \*12: Measured by MobileMark® 2014.  
Varies depending on the usage conditions, or when an optional device is attached.
- \*13: Varies depending on the usage conditions, CPU speed, etc.
- \*14: Approx. 0.5 W when the battery pack is fully charged (or not being charged) and the computer is off.  
<When using with 115 V AC>  
Even when the AC adaptor is not connected to the computer, power is consumed (Max. 0.15 W) simply by having the AC adaptor plugged into an AC outlet.
- \*15: Rated power consumption.
- \*16: Average value. May differ depending on models and options.
- \*17: Do not expose the skin to this product when using the product in a hot or cold environment. (  OPERATING INSTRUCTIONS - Read Me First)  
When using in hot or cold environment, some peripherals and battery pack may fail to work properly. Check the operation environment of the peripherals.  
Using this product continuously in a hot environment will shorten the product life. Avoid use in these types of environments. When using in low temperature environment, startup may become slow or battery operation time may become short.  
The computer consumes power when the flash memory is warming up during startup. Therefore, if you are using battery power and the remaining power is low, the computer may not start up.
- \*18: <Only for North America>  
UL60950 - 1 Evaluated for use at ambient temperatures up to 35 °C {95 °F} when used with optional AC Power Adaptor.
- \*19: Operations of this computer are not guaranteed except for the pre-installed OS and the OS which is installed by using the flash memory recovery and the recovery disc.
- \*20: To continue using this software after the end of the trial, purchase a license by following the on-screen instructions.
- \*21: Must be installed before use.
- \*22: For localized OS model. For information on Wireless Manager, refer to the “Supplementary Instructions” by the following procedure.
  1. Touch and hold  (Start) at the bottom left corner.
  2. Touch [Run], input “c:\util\w\prjct\Supplementary Instructions.pdf” then touch [OK].
- \*23: Only for model with barcode reader.
- \*24: Only for model with GPS or wireless WAN.
- \*25: Panasonic PC Settings Utility includes the following functions: Touch Screen Mode / Touch Operation Support / etc.
- \*26: Only for model with Thermography Camera.
- \*27: Perform on the recovery disc.
- \*28: These are speeds specified in IEEE802.11a+b+g+n+ac standards. Actual speeds may differ.
- \*29: Available when set to “WPA-PSK”, “WPA2-PSK” or “none”.  
Only available when HT40 enabled by the computer and access point which associated supports HT40.



\*30: The specifications may differ depending on the model.

A nanoSIM card (8.8 mm {0.35"} × 12.3 mm {0.48"}) must be inserted in the nanoSIM card slot.



\*31: Operation has been tested and confirmed using Panasonic microSD/microSDHC/microSDXC Memory Cards with a capacity of up to 64 GB.  
Operation on other microSD equipment is not guaranteed.

\*32: To connect the serial device, the serial conversion cable (included) is necessary.

\*33: Exclusively configurable by selecting one from Wireless WAN (with GPS) and GPS.

## The model number is described on the computer

Check according to the procedure below.

1. **Turn over the computer.**

Make sure no foreign objects are under the computer.

2. **Remove the battery pack.**

1. Slide the latch (A).
2. Remove the battery pack (B).

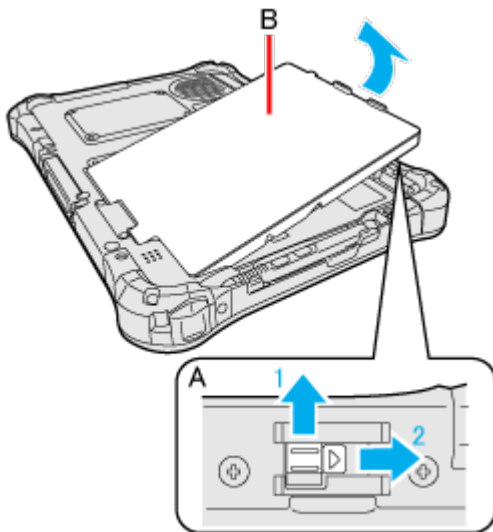

3. **Check the model number. The model number (C) starting with "FZ-G1" is described.**

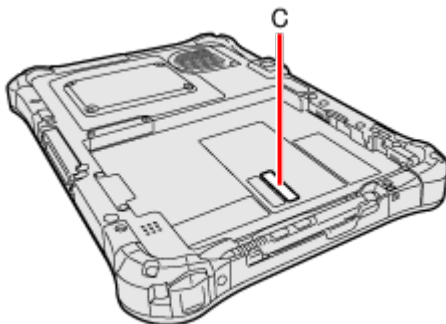

## For U.S.A.

### Panasonic System Solutions Company of North America (PSSNA)

#### Computer Products - Worldwide Warranties

##### **Section 1: Limited Warranty - Hardware**

PSSNA, referred to hereinafter as "Panasonic", will repair the computer products listed below ("Product(s)") with new or rebuilt parts, free of charge in a Global Panasonic designated service location or Panasonic Authorized Service Center for the period specified below from the date of original purchase in the event of a defect in materials or workmanship. These warranties are extended solely to the original purchaser. A purchase receipt or other proof of date of original purchase will be required before warranty performance is rendered.

- Laptop PC (CF-##) - **3 Years**
- Tablet PC / Handheld (FZ-## / JT-##) - **3 Years**
- Ultra-Mobile (CF-U#/CF-H# Series) - **3 Years**
- PDRC - LCD & Keyboard Assembly - **3 Years**

##### **Original Battery Warranty**

Batteries supplied with the product are covered under the warranty for one (1) year from date of purchase. Batteries purchased separately are covered under the warranty for one (1) year from the date of purchase. A replacement battery furnished under the product warranty is covered for the remaining period of the one year warranty on the original or purchased battery.

##### **Optional: Extended Warranty Program (PC)**

If this coverage is purchased, the serial numbered Product is entitled to the same manufacturer's warranty coverage on the Product with the exception of the battery. The cost of labor, parts, and shipping are included in the price of the Extended Warranty Program.

##### **Optional: Panasonic "Protection Plus" Warranty**

Any Product for which the Panasonic "Protection Plus" warranty has been purchased will receive additional coverage for any failure that occurs due to accidental damage. All other terms and conditions of the standard warranty apply and this additional coverage will exist for the duration of the standard warranty period of the Product. If an extended Protection Plus warranty program is purchased, coverage is extended to the end of the last year of extended coverage purchased.

This warranty does not cover failures or defects that are caused by fire, intentional acts, loss, theft, improper maintenance, modification or service by anyone other than a Panasonic Authorized Service Provider, or damage that is attributable to acts of God. Cosmetic damage that does not affect functionality is not covered. Cosmetic damage on Products with hardware failures will be repaired in accordance with the warranty terms. This warranty is extended solely to the original purchaser on the Product's serial number for which it was purchased. Complete Product unit replacement fulfills the full obligation and is at the discretion of Panasonic and is limited to once during the coverage term.

Refer to the Panasonic website for full terms and conditions on the above programs.

- Additional exclusions apply - please refer to limited warranty exclusions section below.

##### **Optional: Panasonic "Ultimate Care" Warranty**

Any Product for which the Panasonic "Ultimate Care" warranty program has been purchased will receive additional coverage as specified in that program, for any failure that occurs due to accidental damage. All other terms and conditions of the standard warranty will apply and this additional warranty coverage will exist for the duration of the standard warranty period of the applicable Product. If an extended warranty is purchased for the Product together with the Ultimate Care warranty program coverage, the warranty term will be extended to the end of the last year of the purchased extended warranty coverage.

The Ultimate Care warranty will cover any hardware failures occurring due to accidental damage of the Product with an exclusion only of customer intentional acts and damage caused by events beyond human control, for up to a maximum of 1% of the total of Products deployed for a specific customer.

This includes unlimited replacement of major sub-assemblies and components of the Product during the standard warranty term and any extended warranty term plan that has been purchased by the customer. This also includes cosmetic damages that may result from exposure of the internal components of the Product to the environmental conditions.

- Additional exclusions apply - please refer to limited warranty exclusions section below.

##### **Wireless Module Warranty**

Panasonic approved wireless modems installed in Panasonic brand computers and integrated by Panasonic or an Authorized Panasonic Wireless Integrator are covered under the warranty for the remaining warranty period of the device in which the modem is installed. For devices with less than three (3) months remaining on the unit warranty, the wireless modem will be covered for a period of three (3) months from the date of installation of the modem, covering only modem replacement or modem installation related issues.

All modems must be approved by the wireless carrier prior to use. Any use or attempted use of a wireless modem not approved and activated by the carrier for use on their network is strictly prohibited and is not sanctioned or warranted by Panasonic and may result in legal action. In addition, all modems must be approved by Panasonic as compatible with the device hardware before installation or use.

Panasonic's sole responsibility for the warranty or technical support of the software required to install or operate the modem is defined in Section 2 (Limited Software Warranty). Any attempted software installation by anyone other than a Panasonic Authorized Wireless Integrator is not covered under warranty and may result in service charges.

Installation or attempted installation by any party other than Panasonic or an Authorized Panasonic Wireless Integrator is strictly not covered under the warranty and may void the computer warranty if damage results.

### **Options and Accessories Warranties**

The below listed Panasonic brand or supplied options and accessories are covered under this limited warranty for the period specified from the date of purchase or as specifically stated:

- AC Adaptor / Power Cord - **3 Years**
- Memory Expansion Card (Panasonic Brand) - **3 Years**
- Car Mount - Docking Station PCB or Vehicle Docking Station - **3 Years**
- Desktop Port Replicator, I-O Box, Docking Cradle (like CF-U1) - **3 Years**
- Antenna Pass-through Cable - **3 Years**
- Backlit or Full-sized keyboard - **3 Years** or assumes warranty of the unit in which it is installed
- Integrated Panasonic supplied options and kits including, but not limited to Wireless Modems, Media Bay Drives (Floppy, CD, DVD, Combo), Camera, GPS, Bluetooth, Smartcard Reader, Magnetic Card Reader, Barcode Reader, and Fingerprint Reader - **3 Years** or assumes warranty period of the unit in which it is installed provided the integration was performed by Panasonic or an Authorized Integrator.
- Hard Drive / Solid State Drive (Internal) - **3 Years**
- Separately purchased 2<sup>nd</sup> Hard Drive - **1 Year**
- External USB Drives (CD / DVD / Floppy / Hard Drive) - **1 Year**
- Optional Battery - **1 Year**
- Battery Charger / Multi-Bay Battery Charger - **1 Year**
- Stylus Pens, Digitizer & Standard - **90 Days** (physical damage excluded)

### **Section 2 - Limited Warranty - Software**

Panasonic warrants to you only that the disk(s) or other media on which the Programs are furnished will be free from defects in material and workmanship under normal use for a period of **sixty (60) days** from the date of delivery thereof to you, as evidenced by your purchase receipt.

This is the only warranty Panasonic makes to you. Panasonic does not warrant that the functions contained in the Programs will meet your requirements or that the operation of the Programs will be uninterrupted or error free. Panasonic shall have no obligation for any defects in the disk(s) or other media on which the Programs are furnished resulting from your storage thereof, or for defects that have been caused by operation of the disk(s) or other media.

Panasonic's entire liability and your exclusive remedy under this warranty shall be limited to the replacement, in the United States or other Panasonic designated location, of any defective disk or other media which is returned to Panasonic's Authorized Service Center, together with a copy of the purchase receipt, within the aforesaid warranty period.

### **Section 3 - Limited Warranty Exclusions** - Specifically excluded from the warranty are:

- All consumable items; such as screen protection films, logo badges, labels, cleaning cloths, carry cases, manuals, cables, straps, belts, holsters, tethers, and harnesses and any other options and accessories not listed above or covered under a separate warranty
- The Warranty excludes 3 or less faulty pixels on the LCD screen
- Failures related to the product operating system, hard drive or solid state drive image, software setup, software program, virus, other program (s) or file(s) on any drive or in any computer memory location
- Failures due to BIOS settings or changes, as well as any cosmetic or physical damage to the unit
- Any unit or device with a missing or altered model number or serial number label
- Cosmetic damage or any damage which occurs in shipment
- Failures which are caused by products not supplied by Panasonic
- Failures which result from alteration, accident, misuse, introduction of liquid or other foreign matter into the unit, abuse, neglect, installation, mal-adjustment of consumer controls, improper maintenance or modification, use not in accordance with product use instructions
- Failures due to service by anyone other than a Panasonic Authorized Service Provider
- Failures caused by improper installation of options or accessories or due to integration by any company other than Panasonic or a Panasonic Authorized Service Center
- Damage, failure, or loss due to the unit being stolen, lost, misplaced, or used by anyone other than the original purchaser
- Damage that is attributable to acts of God

- \* Protection Plus and Ultimate Care warranty programs provide protection against accidental damage. Neither program is intended to provide product refurbishment due to normal wear and tear through normal use.
- \* Customers who have twenty (20) or more units requiring service are required to contact Panasonic at 800-527-8675 and request Field Engineering assistance to coordinate higher volume repairs.

This limited warranty only covers failures due to defects in materials or workmanship which occur during normal use. If a unit is sent to a Panasonic Authorized Service Center and no hardware failure is found, the customer will be billed for labor to correct a software issue or reimage the applicable Hard Disk, or Solid State Drive plus shipping and applicable administrative fees at the current rates set by the service provider.

THIS PRODUCT IS NOT INTENDED FOR USE AS OR PART OF NUCLEAR EQUIPMENT/SYSTEMS, AIR TRAFFIC CONTROL EQUIPMENT/SYSTEMS, OR AIRCRAFT COCKPIT EQUIPMENT/SYSTEMS<sup>\*1</sup>. PANASONIC WILL NOT BE RESPONSIBLE FOR ANY LIABILITY RESULTING FROM THE USE OF THIS PRODUCT ARISING OUT OF THE FOREGOING USES.

\*1 : AIRCRAFT COCKPIT EQUIPMENT/SYSTEMS include class 2 Electronic Flight Bag (EFB) Systems and Class 1 EFB Systems when used during critical phases of flight (e.g., during take-off and landing) and/or mounted onto the aircraft. Class 1 EFB Systems and 2 EFB Systems are defined by FAA: AC (Advisory Circular) 120-76A or JAA: JAA TGL (Temporary Guidance Leaflets) No. 36.

**Other Limits and Exclusions:** There are no other express warranties except as listed above.

PANASONIC SHALL NOT BE LIABLE FOR LOSS OF DATA OR OTHER INCIDENTAL OR CONSEQUENTIAL DAMAGES RESULTING FROM THE USE OF THIS PRODUCT, OR ARISING OUT OF ANY BREACH OF THIS WARRANTY. ALL EXPRESS AND IMPLIED WARRANTIES, INCLUDING THE WARRANTIES OF MERCHANTABILITY AND FITNESS FOR A PARTICULAR PURPOSE ARE LIMITED TO THE APPLICABLE WARRANTY PERIOD SET FORTH ABOVE. Some states do not allow the exclusion or limitation of incidental or consequential damages, or limitations on how long an implied warranty lasts, so the above limitations or exclusions may not apply to you.

This limited warranty gives you specific legal rights, and you may also have other rights which vary from state to state. For technical support or to arrange for service on your Panasonic computer product, call our toll-free hotline at 1-800-LAPTOP5 [option 1] (800-527-8675).

## For Canada

### PANASONIC COMPUTER AND PERIPHERALS LIMITED WARRANTY

**Coverage** - Panasonic Canada Inc. ("PCI") warrants to you, the first end user customer, this computer product (excluding software media), when purchased from PCI or from a PCI authorized reseller, to be free from defects in materials and workmanship under normal use, subject to the terms set forth below, during the period of warranty coverage specified.

Scope of Coverage	Period of Coverage	Type of Failure Coverage
<ul style="list-style-type: none"> <li>• Laptop Computers (except Battery) and AC Adaptor</li> <li>• Factory/PCI installed options including Wireless WAN, GPS, Bluetooth, Finger print reader, Backlit keyboard, Memory Card and Media Bay Drives (Floppy, CD/DVD)</li> <li>• Ultra-Mobile PC</li> <li>• Tablet PC</li> <li>• Mobile Wireless Display</li> <li>• PDRC LCD and Keyboard Assemblies</li> <li>• Port Replicator</li> </ul>	Three (3) Years from Date of Original End User Customer Purchase Defective Materials or Workmanship	Defective Materials or Workmanship
<ul style="list-style-type: none"> <li>• Hand-held Computers</li> <li>• Battery</li> <li>• Battery charger</li> <li>• Auto Adaptor</li> <li>• External USB Drives</li> </ul>	One (1) Year from Date of Original End User Customer Purchase	Defective Materials Workmanship
<ul style="list-style-type: none"> <li>• Standard or Digitizer Stylus Pen</li> </ul>	Ninety (90) Days from Date of Original End User Customer Purchase	Defective Materials or Workmanship
<ul style="list-style-type: none"> <li>• All consumable items including protection film, cleaning cloth, carry case, tether and harness No Coverage</li> </ul>	No Coverage	

**Remedy** - In the event of a warranty claim, contact PCI's representatives within the applicable warranty period, identifying the nature of the defect claimed, at 1-800-668-8386 between 9:00 A.M. and 5:00 P.M., Eastern Time Zone, Mon. - Fri. (excluding holidays) for instructions on how to obtain service. A purchase receipt or other proof of date of original purchase is required before warranty service is performed. Defective parts covered by this Limited Warranty will be repaired or replaced with new or comparable rebuilt parts on an exchange basis. Warranty replacement or repair is subject to the terms of this Limited Warranty for the balance of the original period of warranty coverage.

**No Coverage** - This Limited Warranty does not cover products purchased outside Canada. Neither does it cover damage to, failure of, or defects in a product or accessory through mishandling, improper installation, abnormal use, misuse, neglect, accident, introduction of liquid or other foreign matter into the product, alteration or servicing by anyone not authorized by PCI, or act of God.

THIS PRODUCT IS NOT INTENDED FOR USE AS, OR AS PART OF, NUCLEAR EQUIPMENT/SYSTEMS,

AIR TRAFFIC CONTROL EQUIPMENT/SYSTEMS, OR AIRCRAFT COCKPIT EQUIPMENT/SYSTEMS\*2.

PANASONIC WILL NOT BE RESPONSIBLE FOR ANY LIABILITY RESULTING FROM THE USE OF THIS PRODUCT ARISING OUT OF THE FOREGOING USES.

\*2 : AIRCRAFT COCKPIT EQUIPMENT/SYSTEMS include Class2 Electrical Flight Bag (EFB) Systems and Class1 EFB Systems when used during critical phases of flight (e.g., during take-off and landing) and/or mounted on to the aircraft. Class1 EFB Systems and 2 EFB Systems are defined by FAA: AC (Advisory Circular) 120-76A or JAA: JAA TGL (Temporary Guidance Leaflets) No.36

#### IF YOU SHIP THE PRODUCT FOR WARRANTY SERVICE

Carefully pack the product, preferably in the original carton. Include details of defect claimed and proof of date of original purchase. No liability is assumed for loss or damage to the product while in transit, if you chose your own transportation carrier.

#### SOFTWARE MEDIA LIMITED WARRANTY

**Coverage** - PCI warrants to you, the first end user customer, that the disk(s) or other media on which software program(s) is/are supplied will be free from defects in materials and workmanship under normal use in Canada for a period of sixty (60) days from date of receipt as evidenced by your purchase receipt for your Panasonic Computer product.

THIS IS THE ONLY WARRANTY THAT PCI MAKES RESPECTING THE SOFTWARE MEDIA. PCI does not warrant the software. Please refer to the software licensor's written warranty (accompanying the copy of the software) for any software warranty claim.

**Claim Procedure** - In the event of a defect in material or workmanship in the media during the sixty (60) days warranty period, and you return it, transportation costs prepaid, to Panasonic Canada Inc., Computer Products Marketing, 5770 Ambler Drive, Mississauga, Ontario L4W 2T3, within the warranty period, together with a copy of your purchase receipt, and an explanation of the suspected defect, PCI will replace in Canada the defective disk(s) or other media.

**Remedy** - PCI's entire liability, and your only remedy for any breach of this software media warranty is limited to replacement of the media only. It does not cover any other damages, including, but not limited to, loss of use or profit loss, or special, indirect or consequential damages, or other claims, whether or not of similar character.

**No Coverage** - This limited warranty does not apply if the disk(s) or other media has been used in other than a Panasonic product, or in environmental conditions other than those specified by PCI or the manufacturer, or if subjected to misuse, neglect, mishandling, modification or attempted modification of the program, or if damaged by accident or act of God. PCI is not responsible for damage to or loss of any program, data or removable storage media.

#### GENERAL

NO OTHER WARRANTIES - PCI DISCLAIMS ALL OTHER WARRANTIES, EITHER EXPRESS OR IMPLIED, INCLUDING, BUT NOT LIMITED TO, IMPLIED WARRANTIES OF MERCHANTABILITY AND FITNESS FOR A PARTICULAR PURPOSE, WITH RESPECT TO THE SOFTWARE, SOFTWARE MEDIA, COMPUTER PRODUCT, OPTIONS AND ACCESSORIES.

NO LIABILITY FOR CONSEQUENTIAL DAMAGES - IN NO EVENT SHALL PCI BE LIABLE FOR ANY SPECIAL, INDIRECT OR CONSEQUENTIAL DAMAGES ARISING FROM ANY BREACH OF THE LIMITED WARRANTIES SET OUT IN THIS DOCUMENT, OR FROM THE USE OF THE COMPUTER PRODUCT, INCLUDING, WITHOUT LIMITATION, LOSS OF DATA, BUSINESS, PROFIT OR GOODWILL. IN ANY EVENT, PCI'S MAXIMUM LIABILITY FOR ANY BREACH SHALL NOT EXCEED THE AMOUNT ACTUALLY PAID BY YOU FOR THE COMPUTER PRODUCT. NO ACTION, REGARDLESS OF ITS BASIS, MAY BE BEGUN AGAINST PCI MORE THAN TWO (2) YEARS AFTER THE CAUSE OF ACTION AROSE.

**Statutory Warranties** - Some jurisdictions do not allow these limitations or exclusions, so they may not apply to you.

---

## Pour le Canada

---

#### GARANTIE LIMITÉE - ORDINATEURS ET PÉRIPHÉRIQUES PANASONIC

**Couverture** - Panasonic Canada Inc. (« PCI ») garantit à l'acheteur original que ce produit informatique (à l'exclusion des supports des logiciels) est, au moment de sa vente par PCI ou d'un revendeur agréé par PCI, exempt de défauts de pièces et de fabrication dans les conditions normales d'utilisation, et ce, pendant la période de couverture de la garantie, sous réserve des modalités décrites ci-dessous.

Éléments couverts	Durée de couverture	Type de couverture
-------------------	---------------------	--------------------

<ul style="list-style-type: none"> <li>• Ordinateurs blocs-notes (sauf batteries) et adaptateur secteur</li> <li>• Options installées en usine/par PCI incluant : WAN sans fil, GPS, Bluetooth, lecteur d'empreintes digitales, clavier rétroéclairé, carte mémoire et lecteurs (disquettes, CD/DVD)</li> <li>• Ordinateurs personnels ultra-portables</li> <li>• Ordinateurs tablettes</li> <li>• Écran mobile sans fil</li> <li>• Ensembles PDRC - ACL et clavier</li> <li>• Duplicateur de port</li> </ul>	Trois (3) ans à partir de la date d'achat original.	Défauts de pièces et de fabrication
<ul style="list-style-type: none"> <li>• Ordinateurs de poche</li> <li>• Batterie</li> <li>• Chargeur de batterie</li> <li>• Adaptateur pour voiture</li> <li>• Périphériques USB</li> </ul>	Un (1) an à partir de la date d'achat original.	Défauts de pièces et de fabrication
<ul style="list-style-type: none"> <li>• Stylo pointe standard ou pour numériseur graphique</li> </ul>	Quatre-vingt-dix (90) jours à partir de la date d'achat original.	Défauts de pièces et de fabrication
<ul style="list-style-type: none"> <li>• Tous les articles consommables incluant les pellicules protectrices, chiffons de nettoyage, étuis de transport, longes et sangles</li> </ul>	Aucune couverture	

**Recours** - Pour obtenir des informations sur la marche à suivre dans le cas où une réclamation en vertu de la garantie deviendrait nécessaire, communiquez par téléphone avec un représentant de PCI au 1-800-668-8386, entre 9h00 et 17h00 (heure de l'Est) du lundi au vendredi (sauf les jours fériés), avant l'échéance de la garantie applicable, en prenant soin d'identifier la nature de la défaillance.

Un reçu ou toute autre pièce justificative de la date d'achat original sera exigé avant toute réparation. Toute pièce défectueuse couverte par la présente garantie limitée sera réparée ou remplacée par une pièce neuve ou remise à neuf. Le remplacement ou la réparation sera fait conformément aux modalités de la présente garantie limitée pendant la durée restante de la période originale de la garantie.

**Produits non couverts** - La présente garantie limitée ne couvre pas les produits achetés à l'extérieur du Canada. Elle ne couvre pas non plus les dommages, la défaillance ou les défauts attribuables à une maintenance inadéquate, une mauvaise installation, une utilisation anormale ou abusive, de la négligence, un accident, un déversement ou la pénétration d'un objet étranger, une modification, un cas fortuit ou une réparation effectuée par une personne non agréée par PCI. CE PRODUIT N'EST PAS DESTINÉ À ÊTRE UTILISÉ, EN TOUT OU EN PARTIE, COMME SYSTÈME/ÉQUIPEMENT NUCLÉAIRE, SYSTÈME/ÉQUIPEMENT DE CONTRÔLE DU TRAFFIC AÉRIEN OU SYSTÈME/ÉQUIPEMENT DE POSTE DE PILOTAGE D'AVION\*3. PANASONIC DÉCLINE TOUTE RESPONSABILITÉ CONCERNANT L'UTILISATION DE CE PRODUIT DANS LES CAS SUSMENTIONNÉS.

\*3 : Les SYSTÈMES/ÉQUIPEMENTS DE POSTE DE PILOTAGE D'AVION sont dotés de systèmes OEPP (organiseur électronique de poste de pilotage) de classe 2 et de classe 1 utilisés pendant des phases critiques de vol (par exemple, pendant le décollage et l'atterrissage) et(ou) montés sur l'avion. Les systèmes OEPP de classe 1 et de classe 2 sont définis par le circulaire d'information FAA: AC (Advisory Circular) 120-76A ou le feuillet n° 36 JAA: JAA TGL (Temporary Guidance Leaflets) No 36.

#### EXPÉDITION DU PRODUIT POUR SERVICE SOUS GARANTIE

Emballer soigneusement le produit, de préférence dans son emballage d'origine. Joignez une description de la défaillance de même qu'une pièce justificative de la date d'achat. Panasonic Canada Inc. ne peut être tenue responsable pour tout dommage ou perte subi pendant le transport si vous avez choisi le transporteur.

#### GARANTIE LIMITÉE - SUPPORTS DES LOGICIELS

**Couverture** - Panasonic Canada Inc. (« PCI ») garantit à l'acheteur original que la ou les disquettes ou tout autre support sur lequel le ou les programmes sont fournis sont exempts de défauts de pièces et de fabrication dans des conditions normales d'utilisation au Canada, et ce, pour une période de soixante (60) jours suivant la date de réception indiquée sur la preuve d'achat.

LA PRÉSENTE GARANTIE EST LA SEULE OFFERTE PAR PCI COUVRANT LES SUPPORTS DE LOGICIELS. PCI ne garantit pas les logiciels. Reportez-vous à la garantie écrite du concédant de licence d'utilisation du logiciel (qui accompagne la copie du logiciel) pour toute réclamation en vertu de la garantie.

**Réclamation** - marche à suivre - Panasonic Canada Inc. remplacera toute disquette ou support défectueux si l'article en question est retourné, port payé, à son service de Marketing - produits informatiques, 5770 Ambler Drive, Mississauga (Ontario) L4W 2T3, dans les soixante (60) jours suivant la date d'achat original. Joignez à votre envoi une pièce justificative de votre achat et une description du problème.

**Recours** - La responsabilité de PCI - et votre seul recours - dans le cas de toute défaillance couverte par la garantie sur ce support de logiciel est limitée au seul remplacement du support. Elle ne couvre aucun autre dommage, y compris, mais non exclusivement, la perte d'usage ou de profits, ni aucun dommage spécial, indirect ou consécutif, ni aucune autre réclamation de nature similaire ou autre.

**Produits non couverts** - La présente garantie limitée ne s'applique pas si la ou les disquettes ou autre support ont été utilisés dans un produit d'une marque autre que Panasonic ou dans des conditions environnementales autres que celles spécifiées par PCI ou le fabricant, ou soumis à une mauvaise utilisation, à la négligence, à une manutention inadéquate ou encore si le programme a été modifié ou subi une tentative de modification ou des dommages attribuables à un accident ou à un cas fortuit. De plus, PCI n'assume aucune responsabilité pour toute perte de, ou tout dommage à, un programme, des données ou un support de sauvegarde amovible.

### GÉNÉRALITÉS

PCI NE RECONNAÎT AUCUNE AUTRE GARANTIE, EXPLICITE OU IMPLICITE, Y COMPRIS, MAIS NON EXCLUSIVEMENT, LES GARANTIES IMPLICITES DE VALEUR COMMERCIALE ET D'UTILITÉ À UNE FIN QUELCONQUE, À L'ÉGARD DU LOGICIEL, SUPPORTS DE LOGICIELS, PRODUITS INFORMATIQUES, PÉRIPHÉRIQUES ET ACCESSOIRES.

SOUS AUCUNE CIRCONSTANCE PCI NE POURRA ÊTRE TENUE RESPONSABLE DES DOMMAGES SPÉCIAUX, INDIRECTS OU CONSÉCUTIFS ATTRIBUABLES À UN MANQUEMENT AUX GARANTIES LIMITÉES DÉCRITES DANS LE PRÉSENT DOCUMENT OU À L'UTILISATION DU PRODUIT INFORMATIQUE, Y COMPRIS, SANS RESTRICTION, LA PERTE DE DONNÉES, D'AFFAIRES, D'ACHALANDAGE OU DE PROFIT.

DANS TOUS LES CAS, LA RESPONSABILITÉ MAXIMALE DE PCI POUR TOUT MANQUEMENT NE POURRA EXCÉDER LE PRIX DE VENTE DU PRODUIT INFORMATIQUE. AUCUNE RÉCLAMATION, SANS ÉGARD À SES MOTIFS, NE POURRA ÊTRE FAITE AUPRÈS DE PCI PLUS DE DEUX (2) ANS APRÈS LES FAITS INVOQUÉS À LA BASE D'UNE TELLE RÉCLAMATION.

**Garantie statutaires** - Certaines juridictions interdisent de telles limitations ou exclusions; aussi, pourraient-elles ne pas s'appliquer.

---

## For Europe

---

# Panasonic System Communications Company Europe

Panasonic System Communications Company Europe (referred to as "Panasonic") will repair this product (other than software, which is treated in a different section of this warranty) with new or refurbished parts, from the date of original purchase in the event of a defect in materials or workmanship.

This warranty only applies to new Panasonic Toughbooks purchased in the EEA and Switzerland and Turkey.

Panasonic (or its authorised Service Provider) target to repair your equipment within 48 hours from its receipt in our service centre.

Additional charges may apply for shipment to countries outside of the European Union. Panasonic will use all reasonable endeavours to ensure this service.

This warranty only covers failures due to defects in materials or workmanship which occur during normal use for the applicable Service Agreement Period listed below. In the event that any product (or part thereof) is replaced, Panasonic shall transfer ownership of the replacement product (or part) to the customer and the customer shall transfer ownership of the replaced product (or part) to Panasonic.

### **Service Agreement Period - from original date of purchase**

- Toughbooks (and every accessory included in the original packaging except the battery) - 3 years
- Toughpads (and every accessory included in the original packaging except the battery) - 3 years
- Accessories included in the original package - 3 years
- Additional peripherals manufactured by Panasonic (including media bay devices such as CD-Rom drives) - 1 year
- Batteries - 6 months. Panasonic Warranty covers the battery for six months. A battery is considered good if it maintains 50% of its charge capacity during the warranty period. If a battery is returned under this contract and testing determines that it has charge capacity greater than 50%, the battery will be returned with an invoice for the retail purchase price of a new battery.

This warranty is extended solely to the original purchaser. A purchase receipt or other proof of date of original purchase will be required before warranty performance is rendered.

### **Limits and Exclusions:**

This warranty does not cover and shall be void for:

- Broken or cracked LCD screen.
- Defective pixel in notebook displays and LCD screens within 0.002%
- Damage that is attributable to fire, theft or acts of God.
- Damage caused by environmental influences (electrical storms, magnetic fields etc.).
- Damage which has not been caused during normal operation
- Repair of damage that is cosmetic only or does not affect product functionality such as wear and tear, scratches and dents.
- Failures caused by products not supplied by Panasonic.
- Failures resulting from alteration, accidental damage, casualty, misuse, abuse or neglect.
- Introduction of liquid or other foreign matter into the unit.

- Improper installation, operation or maintenance.
- Improper connections with peripherals.
- Maladjustment of consumer controls such as function settings.
- Modification or service by anyone other than Panasonic or its approved Service Providers.
- Products used as short term rental or leased equipment.
- Products whose serial number has been removed making the unit warranty condition impossible to clearly determine.

THIS PRODUCT IS NOT INTENDED FOR USE AS, OR AS PART OF, NUCLEAR EQUIPMENT/SYSTEMS, AIR TRAFFIC CONTROL EQUIPMENT/SYSTEMS, OR AIRCRAFT COCKPIT EQUIPMENT/SYSTEMS. PANASONIC WILL NOT BE RESPONSIBLE FOR ANY LIABILITY RESULTING FROM THE USE OF THIS PRODUCT ARISING OUT OF THE FOREGOING USES.

There are no other express warranties except as listed above.

We strongly recommend that customers backup their data before sending back their unit to an Authorised Service Provider.

Panasonic shall not be liable for loss of data or other incidental or consequential damages resulting from the use of this product, or arising out of any breach of this warranty. All express and implied warranties, including the warranties of satisfactory quality and fitness for a particular purpose are limited to the applicable warranty period set forth above. Panasonic shall not be liable for any indirect, special or consequential loss or damage (including without limitation any loss of profits) arising from the use of this product or for any breach of this warranty.

This limited warranty gives you specific legal rights, and you may have other rights that vary from country to country. You must consult the applicable country laws for a full determination of your rights. This limited warranty is in addition to, and does not affect any rights arising out of any contract of sale or by statute.

### Data Storage Media

Data Storage Media is the media on which the Operating System, drivers and programs originally installed by Panasonic on the tablet are stored. This media is originally provided with the unit.

Panasonic warrants to you only that the disc(s) or other media on which the Programs are furnished will be free from defects in material and workmanship under normal use for a period of sixty (60) days from the date of delivery thereof to you, as evidenced by your purchase receipt.

This is the only warranty Panasonic makes to you. Panasonic does not warrant that the functions contained in the Programs will meet your requirements or that the operation of the Programs will be uninterrupted or error free.

Panasonic's entire liability and your exclusive remedy under this warranty shall be limited to the replacement of any defective disk or other media which is returned to Panasonic's authorized Service Centre, together with a copy of the purchase receipt, within the aforesaid warranty period.

Panasonic shall have no obligation for any defects in the disk(s) or other media on which the Programs are furnished resulting from your storage thereof, or for defects that have been caused by operation of the disk(s) or other media otherwise than on the Product or in the environment conditions other than those specified by Panasonic by alteration, accident, misuse, abuse, neglect, mishandling, misapplication, installation, maladjustment of consumer controls, improper maintenance, modification or damage that is attributable to acts of God. In addition, Panasonic shall have no obligation for any defects in the disk(s) or other media if you have modified, or attempted to modify any Program.

Duration of implied warranties, if any is limited to sixty (60) days.

### Pre-installed software

Pre-installed software means the software shipped pre-loaded by Panasonic, not that loaded by any third party or selling agent.

Panasonic and its suppliers makes no warranty, either express, implied or statutory, with respect to software provided with the Product and licensed to Purchaser, its quality, performance, merchantability, or fitness for a particular purpose. Panasonic does not warrant that the functions contained in the software will be uninterrupted or error free. Panasonic assumes no risk of and shall not in any case be liable for any damages, including, without limitation, any special, incidental, consequential, or punitive damages arising from breach of warranty or contract, negligence or any other legal theory, including, without limitation loss of goodwill, profits or revenue, loss of use of the Programs or Products or any associated equipment, cost of any substitute equipment, facilities, or services, downtime costs, or claims of any party dealing with such damages.

Some countries do not allow the exclusion or limitation of incidental or consequential damages, or limitations on how long an implied warranty lasts, so the above limitations or exclusions may not apply to you.

This limited warranty gives you specific legal rights and you may also have other rights that vary from country to country. You must consult applicable country laws for a full determination of your rights.

### Contacts

**Address** Panasonic System Communications Company Europe  
Panasonic Manufacturing U.K. Ltd.  
Service Centre Building B4,  
Wharfedale Road, Pentwyn Industrial  
Estate, Cardiff,  
United Kingdom  
CF23 7XB

**Web page** <https://business.panasonic.co.uk/computer-product/>



**Help desk**

English speaking service	+44 (0) 800 0884324
French speaking service	+33 (0) 80 5636449
German speaking service	+49 (0) 800 7235211
Italian speaking service	+39 800 986915
Spanish speaking service	+34 (0) 901 101 157
Austria	+43 (0) 800 006493
Switzerland (German)	+41 (0) 800 002429
Switzerland (French)	+41 (0) 800 588017
E-mail address	toughbooksupport@eu.panasonic.com

Czech speaking service	+420 (0) 800 143234
Hungarian speaking service	+36 (0) 6800 163 67
Polish speaking service	+48 (0) 800 4911558
Romanian speaking service	+40 (0) 800 894 743
Slovakian speaking service	+421 (0) 800 42672627
E-mail address	toughbooksupport@csg.de

Payments	toughbookservicepayments.cardiff@eu.panasonic.com
----------	---